

Alloy Valves and Control

Actuator Specifications	P0800		P1300	
Torque	800 in.lbs/90 Nm		1335 in.lbs/150 Nm	
Supply Voltage	120V AC	230V AC	120V AC	230V AC
Max Inrush Current	1.8A	0.8A	1.8A	1.2A
Running Current	1.0A	0.5A	1.2A	1.0A
Motor	Split Phase Capacitor			
Runtime (90°@60Hz)	15 sec		22 sec	
Runtime (90°@50Hz)	17 sec		26 sec	
Duty Cycle	25%, Proportional: Managed (75% maximum)			
Motor Starts	1200 per hour			
Weight	26 lbs/12 kg			
Mechanical Connections	ISO 5211 F07 8 point 22mm			
Electrical Entry	3/4" NPT (2 places)			
Electrical Terminations	12-16 gage			
Environmental Rating	NEMA 4/4X			
Manual Override	5" Handwheel			
Control	On/Off/Jog/Proportional			
Actuator Case Material	Aluminum Alloy, Powder coated			
Motor Protection	230°F/110°C Thermal F* Class *Totally Enclosed Non-Ventilated Motors			
Ambient Temperature Operating Range	-22°F to +125°F/-30°C to +52°C			



An electric actuator designed for load requirements ranging from 800 to 1335 lbs. The actuator comes standard with two auxiliary switches (Form C), an internal low power heater, a NEMA 4X environmental rating, and in 120vac or 230vac supply voltages. The P0800/1300 mechanical connections are ISO 5211 compliant. The P0800/1300 Series can be ordered as an on/off (two position) model that can also be used in bump/jog applications. Models can also be ordered with an internal proportional control card that accepts a wide range of control signals and generates multiple feedback signals for field use.

HOW TO ORDER

P0800	4X	120A		
Model	Enclosure	Voltage	Control	Options
P0800 - 800 in.lbs model	4X - NEMA 4X	120A - 120V AC	blank - On/Off	See last page
P1300 - 1335 in.lbs model		230A - 230V AC	P - Proportional	

Example ordering codes: P0800-4X-120A = 120V AC 800 in./lbs Electric actuator with On/Off control
P1300-4X-230A-P = 230V AC 1335 in.lbs Electric actuator with Proportional control

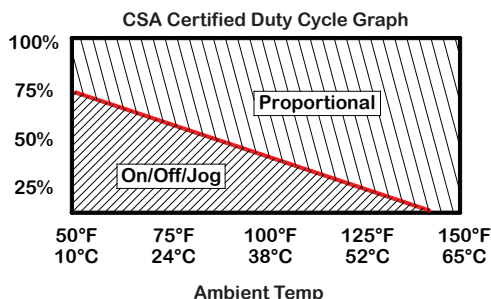

- Duty cycle is defined as the ratio of total time vs. run time, and is a function of environmental conditions including ambient temperature, supply voltage and control signal stability
- Duty Cycle rating on all proportional control actuators is managed (75% maximum).

Also available in 12V & 24V AC or DC operation, and in 3 phase supply. Separate spec sheets are available for these configurations.

Contact AVCO for more information.

Alloy Valves and Control

P0800/1300 Series Dimensional Data

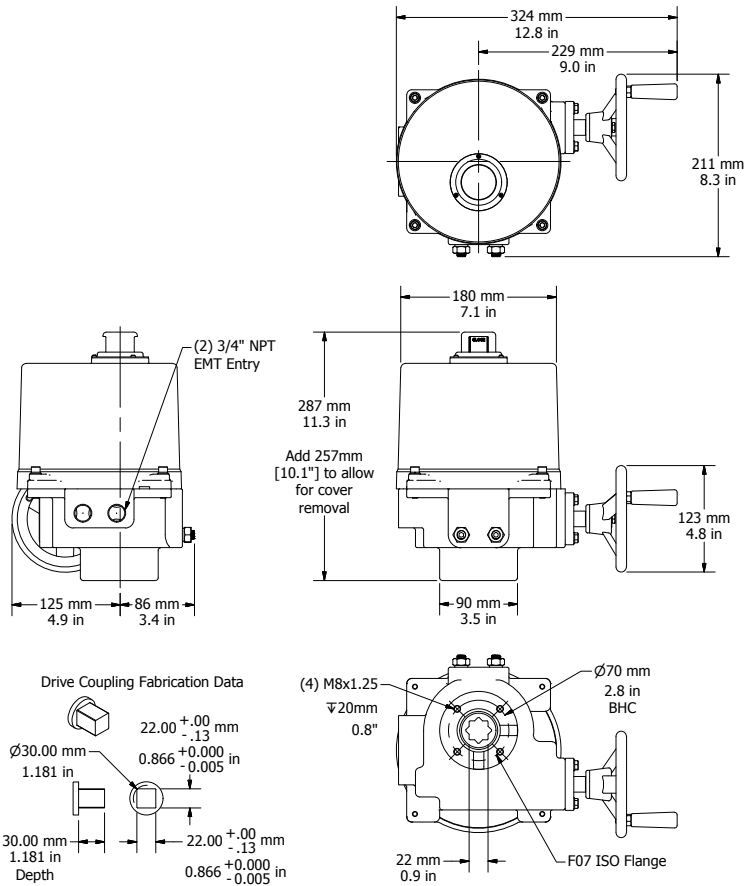

P Series Exploded View

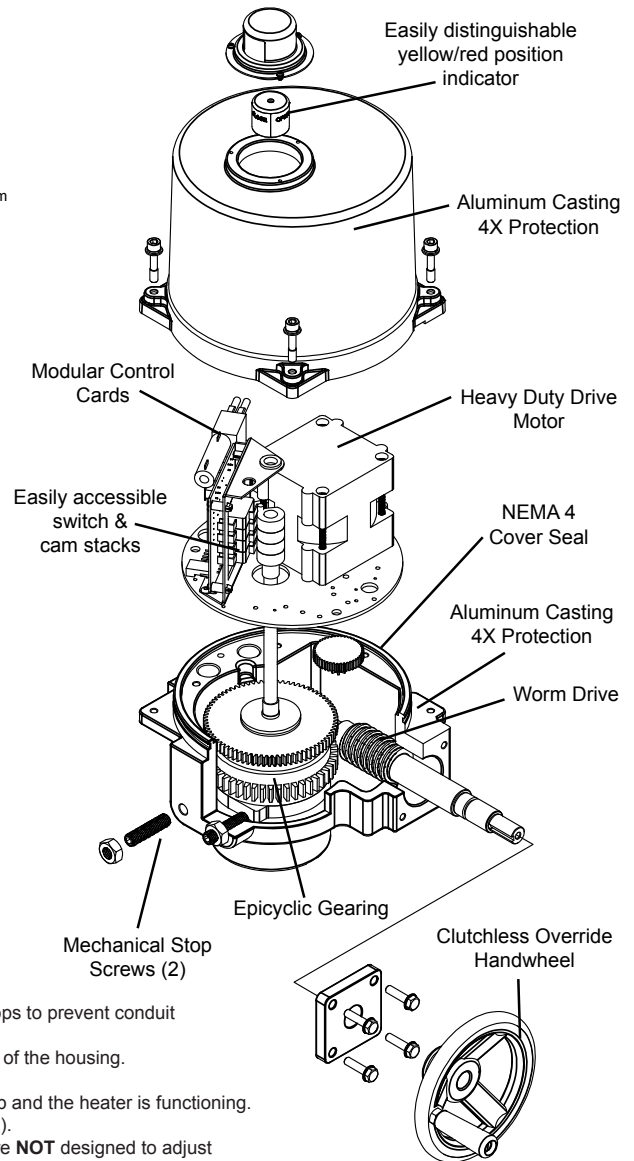

Application Notes:

1. These actuators are to be mounted **ONLY** between a horizontal and upright position.
2. When installing conduit, use proper techniques for entry into the actuator. Use drip loops to prevent condensate from entering the actuator.
3. Both NPT conduit ports **MUST** use proper equipment to protect the NEMA 4x integrity of the housing.
4. The internal heater is to be used in **ALL** applications.
5. **Do NOT** install the actuator outdoors or in humid environments unless it is powered up and the heater is functioning.
6. Use proper wire size to prevent actuator failure (see chart below for proper wire sizing).
7. Mechanical travel stops are factory calibrated for 90 degree operation. These stops are **NOT** designed to adjust mechanical rotation by more than +/- 3 degrees.
8. **Do NOT** parallel wire multiple actuators together without utilizing isolation relays! If this is your intention, please contact AVCO for a multiple actuator parallel wiring diagram.

Switch Logic Map and Switch/Cam Arrangement

Switch sequencing data is provided in the table below to show the change-of-state points during the rotation of the actuator from OPEN to CLOSED and back again. The red bar indicates when that terminal makes with it's respective common.

SW1 and SW2 are set at the factory and should NOT be changed. The INCLUDED auxiliary switches SW3 & SW4 are for terminals 7 thru 12 and those setpoints may be modified if need be. When so optioned, SW5 & SW6 auxiliary switches are initially set to function the same as auxiliary switches SW3 & SW4.

Terminal ID#	CW			CCW		
	-5°	0°	5°	85°	90°	95°
12		Not Open				
11		Open Common				
10			Open			
9			Not Closed			
8			Closed Common			
7			Closed			

SW4 CW AUX
(Factory Set - Adj)

SW3 CCW AUX
(Factory Set - Adj)

Used by
Controller

On/Off Switch/Cam arrangement shown

Wiring Diagrams for P0800/1300 Series

- Field Control Device may be relay contact, Switch or Triac type.
- Pilot device 10A MAX. Auxiliary switches are rated 10A @ 250V AC MAX.
- Terminals 7-12 are dry type Form C.
- Terminals accept 12-16ga solid/stranded wire.

Sample Diagram

Refer to the proper IOM for your actuator for the correct wiring diagram

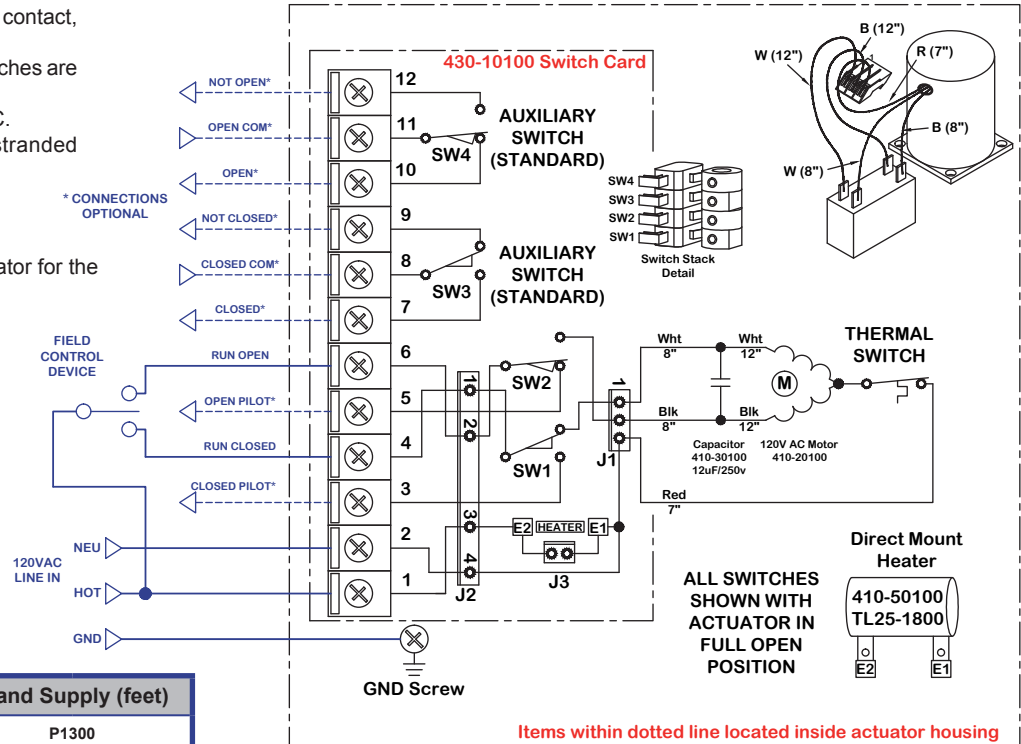

Wire Sizing Chart

Wire Gage	Max distance between Actuator and Supply (feet)			
	P0800		P1300	
	120V AC 1.8A	230V AC 0.8A	120V AC 1.8A	230V AC 1.2A
16	722	3111	722	2074
14	1166	5026	1166	3351
12	1783	7687	1783	5125
10	3030	13068	3030	8712
8	4523	19505	4523	13003

Wire sizing data is provided in the table below to assist in the selection of the proper wire size for AVCO P0800/1300 series actuators using various wire sizes over distance. Please make sure to reference the correct voltage and do not exceed the indicated length of the wire run for each model.

Proportional Control

AVCO Premium Controller

The Premium controller offers a full array of features - such as various control and feedback signals, alphanumeric readout, several fault indicators for operational diagnostics, extensive data logging that provides full proportional control for all industrial applications. ModBus communications are also an option on this controller.

Full Proportional Control Featuring:

- Auto-calibration
- Programmable
- High resolution
- Alarm Outputs
- Data logging
- Simple User Interface
- Field Selection Friendly
- Thermal Management



Control Signal Input

(selectable using program menu):
0-10V DC, 1-5V DC, 2-10V DC, 4-20mA
Factory set with common isolated from ground. Ground reference is possible.

Signal	Input Impedance	Sensitivity
0-10V DC	140k ohms	50mV
1-5V DC	250k ohms	20mV
2-10V DC	140k ohms	40mV
4-20mA	250 ohms	80µA

Feedback Signal Outputs

(Can be different to input):
0-10V DC, 1-5V DC, 2-10V DC, 4-20mA
Max Load: 250 ohms

Auxiliary Signal Outputs

(Programmable):
Alarm Contacts allow for signaling of 5 different fault conditions.

2 Position Control

Contacts and capability for 2 position (only) override of the actuator.

Alloy Valves and Control**AVAILABLE OPTIONS (Factory Installed)**

- Premium Proportional Controller Option. Converts 2 position to proportional control.
- Extended Duty Motor - 75% Duty Cycle.
- Single Wire Control Relay (Internal) Units operate NORMALLY CLOSED - ENERGIZE TO OPEN.
- Single Wire Control Relay (Internal) Units operate NORMALLY OPEN- ENERGIZE TO CLOSED.
- Mechanical Torque Switch Assembly. Excludes proportional control versions.
- IP68 Protection, tested to 0.7kgf/cm² for 72 hours.
- 0-45-90 degree rotation option.
- 0-90-180 degree rotation option.
- 0-180 degree rotation option. No Mid-point position is offered. (On/Off only).
- 1k ohm position feedback potentiometer.
- 5k ohm position feedback potentiometer.
- 10k ohm position feedback potentiometer.
- 4-20mA feedback generator for On/Off/Jog actuators.
- Auxiliary Switch set. Provides 3rd and 4th auxiliary switches (Form C x 2).
- Adjustable Timer, Dual Set Point Timer (Duration and Frequency) (Contact factory for application assistance).
- Proportional Control Signal override capability (OPEN OR CLOSED).
- Integral Thermostat for Heater Control - turns on at 32°F, turns off at 50°F.
- Cold weather auxiliary heater option. Thermostatically controlled, On 32°F, Off at 50°F, auto reset, hermetically sealed, 120/230V AC On/Off/ Jog type actuators. 175W Internal Heater, 2A power consumption.
- Timer function which slows actuator rotation (cycle time) using an internally mounted octal timer. (Contact factory for application assistance).
- Chain wheel override for applications where an actuator is mounted some distance from the floor. (Use with LCS).
- Local Control Stations (LCS) AVCO LCSs are designed to be remotely located or directly mounted to the actuator. Proportional actuators will have different options than On/Off. Available in steel, stainless, or fiberglass enclosures. (See catalog for additional Local Control Selections).
- 3 Phase models with or without Motor Control Center.
- Optional SCADA and Modbus compatibility.
- Epoxy coating for increased environmental protection.
- Nylon coating for increased environmental protection.
- Stainless Steel enclosure.