

# Chicago Valves & Controls



**CLASS 150/300/600**

**FLANGE FORGED STEEL**

**GATE GLOBE AND CHECK**



# GATE VALVE

CLASS 150/300/600

FORGED STEEL  
RISING STEM  
BOLTED BONNET  
NACE-MR-0175

Gate valve - Flange class  
150/300/600

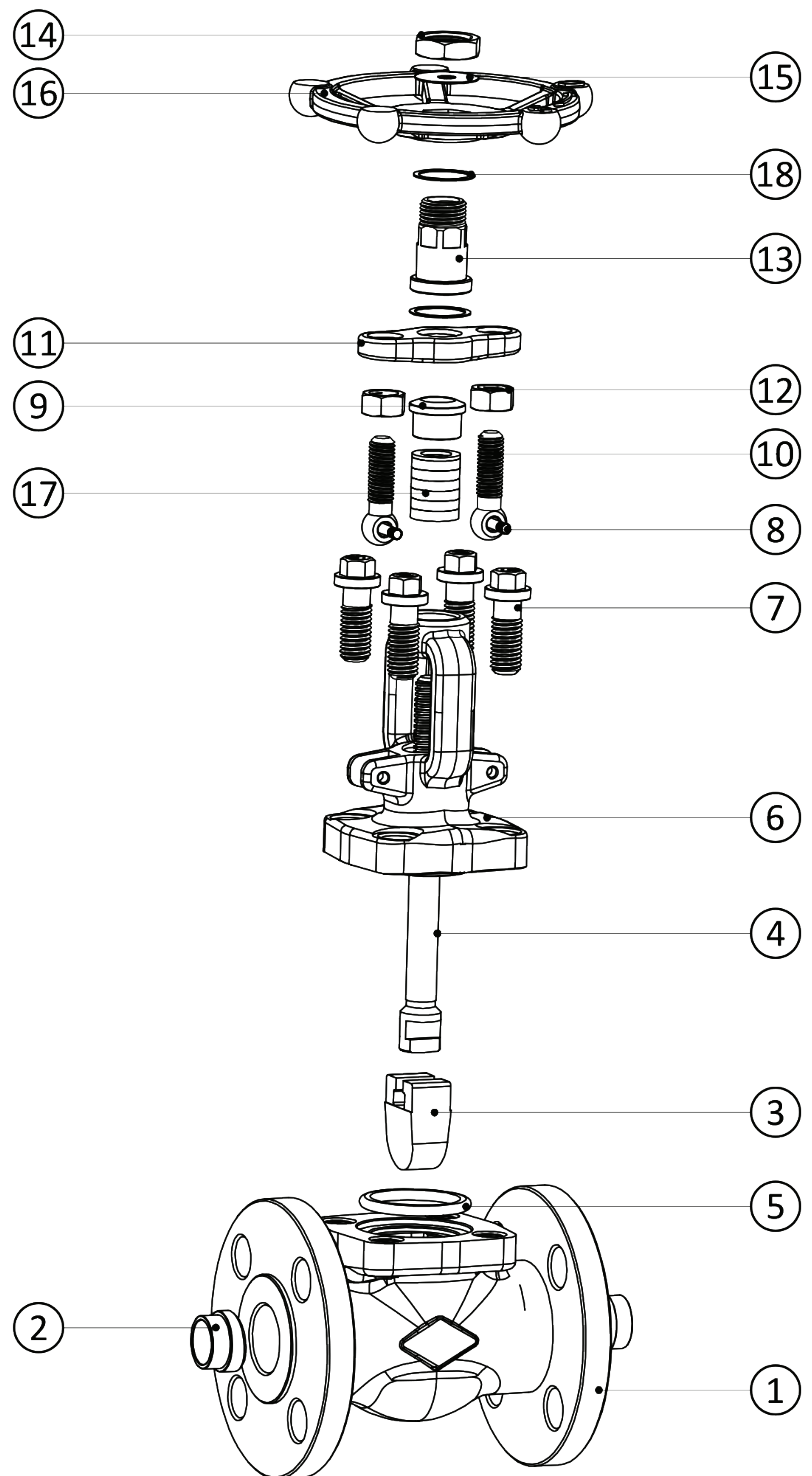

## PARTS & MATERIAL

PART NO.	PART NAME	QTY.	MATERIAL
1	Body	1	ASTM A 105N
2	Seat Ring	2	ASTM A 276 Type SST.-410
3	Disc	1	ASTM A 217 GR. CA-15
4	Stem No Casting	1	ASTM A 182 GR. F6a CL.2
5	Gasket	1	SS-316 Spiral Wound+Graphite
6	Bonnet	1	ASTM A 105N
7	Bonnet Bolt	4	ASTM A 193 GR. B7M
8	Eye Bolt Pin	2	ASTM A 276 TYPE SST.-410
9	Nut	2	ASTM A 276 TYPE SST.-410
10	Eye Bolt	2	ASTM A 193 GR. B7M
11	Gland Flange	1	ASTMA 105N
12	Eye Bolt Nut	2	ASTM A 194.GR. 2HM
13	Yoke Sleeve	1	ASTM 582 GR. SST.-416
14	Stem Nut	1	ASTM A 194.GR. 2HM
15	Name Plate	1	Stainless Steel
16	Hand Wheel	1	MI / Sgiron
17	Gland Packing	1 Group	Graphite
18	Waher	1	A 276-410



# Gate valve - Flange class 150/300/600

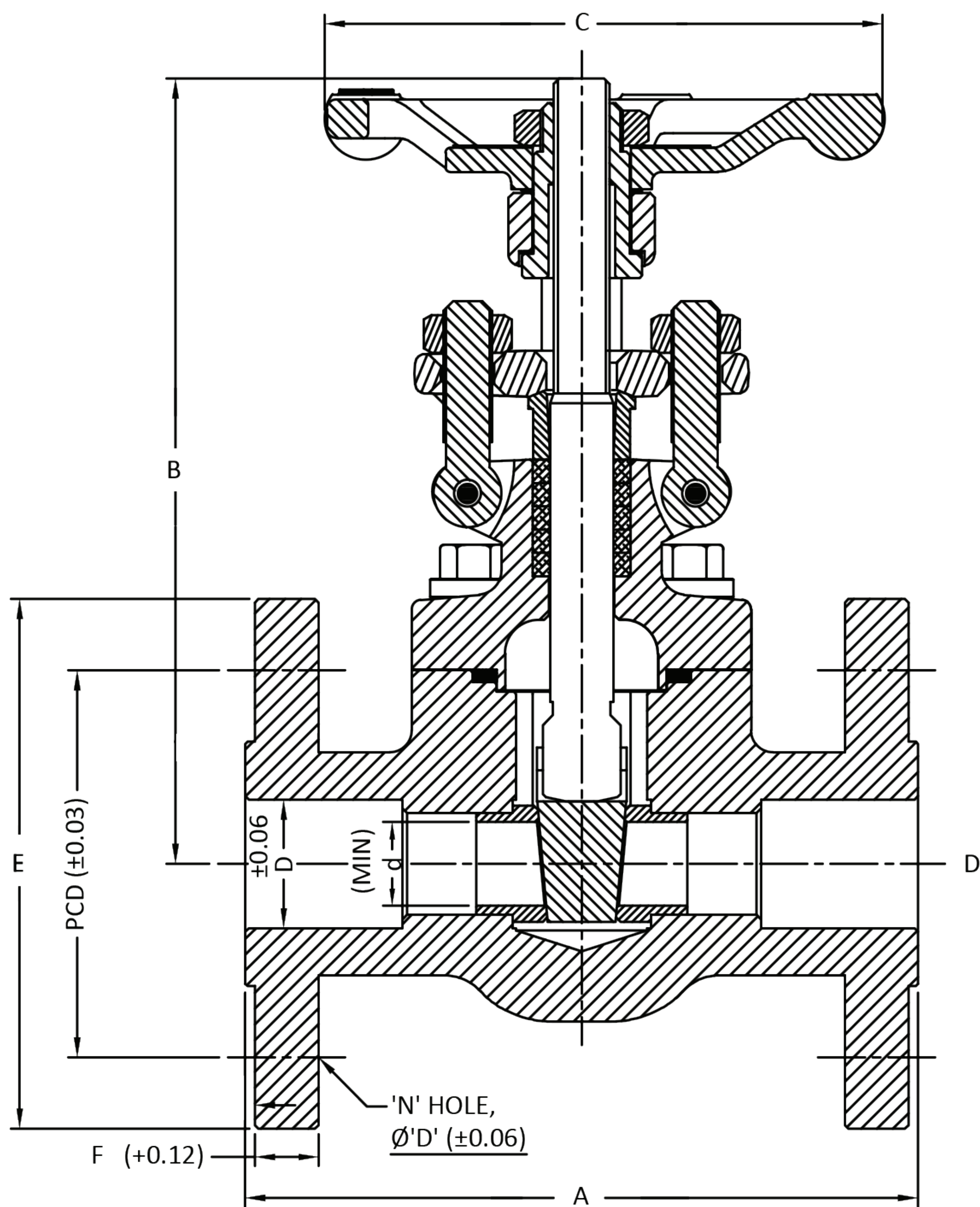

**DIMENSIONS (INCHES) CLASS 150**

SIZES	A	D	d	E	F	N	ØD	PCD	C	B
1/2"	4.25	0.62	0.37	3.54	0.31	4	0.63	2.37	3.39	5.98
3/4"	4.63	0.82	0.50	3.94	0.35	4	0.63	2.75	3.39	6.34
1"	5.00	1.05	0.69	4.33	0.38	4	0.63	3.13	4.57	7.24
1 1/4"	5.51	1.37	0.90	4.52	0.44	4	0.63	3.50	4.57	7.48
1 1/2"	6.50	1.61	1.13	4.92	0.50	4	0.63	3.87	5.91	9.65

**DIMENSIONS (INCHES) CLASS 300**

SIZES	A	D	d	E	F	N	ØD	PCD	C	B
1/2"	5.51	0.62	0.37	3.74	0.50	4	0.63	2.63	3.39	5.98
3/4"	6.00	0.82	0.50	4.53	0.56	4	0.75	3.25	3.39	6.34
1"	6.50	1.05	0.69	4.92	0.63	4	0.75	3.50	4.57	7.24
1 1/4"	7.00	1.37	0.90	5.31	0.69	4	0.75	3.87	4.57	7.48
1 1/2"	7.52	1.61	1.13	6.10	0.75	4	0.87	4.50	5.91	9.65

**DIMENSIONS (INCHES) CLASS 600**

SIZES	A	D	d	E	F	N	ØD	PCD	C	B
1/2"	6.50	0.62	0.37	3.54	0.31	4	0.63	2.37	3.39	5.98
3/4"	7.50	0.82	0.50	3.94	0.35	4	0.63	2.75	3.39	6.34
1"	8.50	1.05	0.69	4.33	0.38	4	0.63	3.13	4.57	7.24
1 1/4"	9.00	1.37	0.90	4.52	0.44	4	0.63	3.50	4.57	7.48
1 1/2"	9.50	1.61	1.13	4.92	0.50	4	0.63	3.87	5.91	9.65



# GLOBE VALVE

CLASS 150/300/600

FORGED STEEL  
BOLTED BONNET  
RISING STEM  
NACE-MR-0175

Globe valve - Flange class  
150/300/600

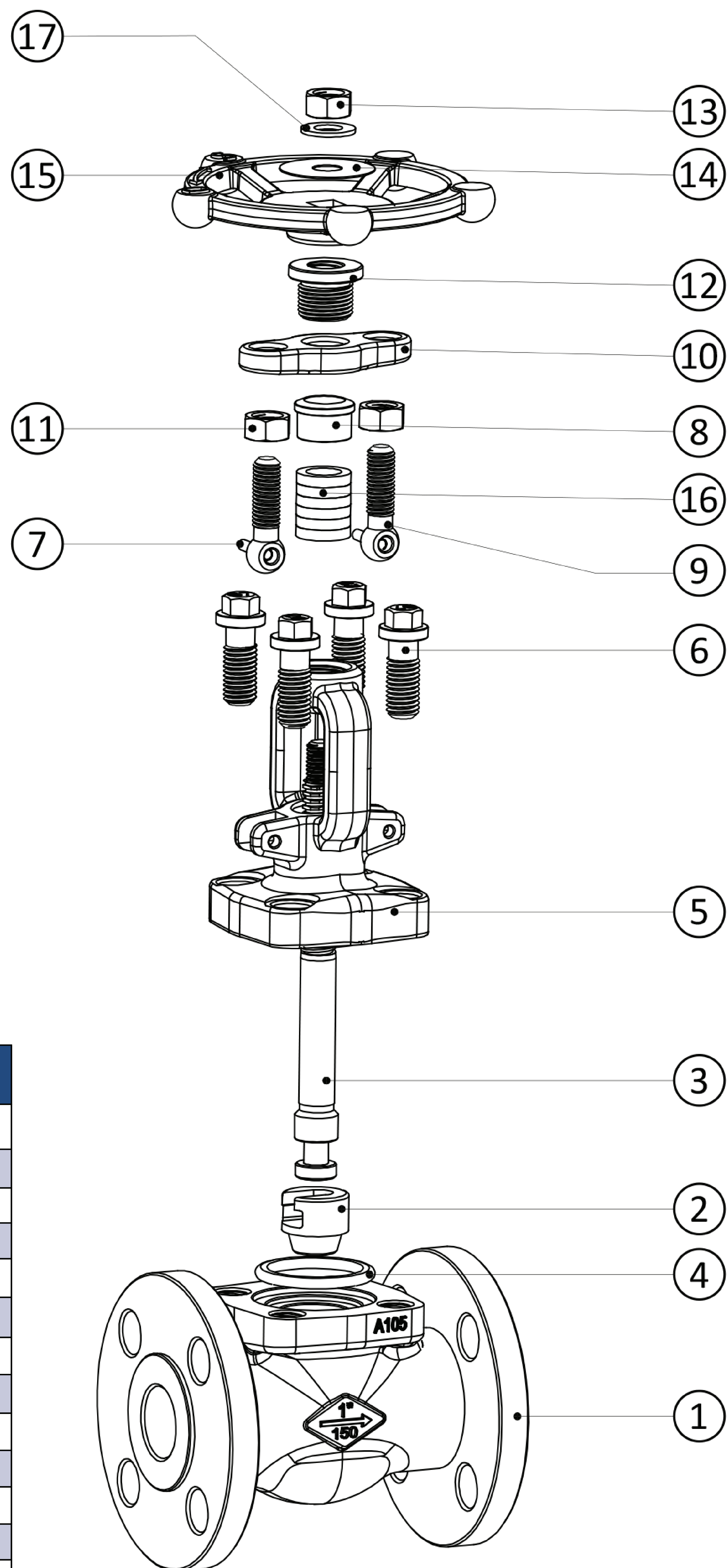

## PARTS & MATERIAL

PART NO.	PART NAME	QTY.	MATERIAL
1	Body	1	ASTM A 105N
2	Disc	1	ASTM A 217 GR. CA-15
3	Stem	1	ASTM A 182 GR. F6a CL.2
4	Gasket	1	SST.-316 Spiral Wound+Graphite
5	Bonnet	1	ASTM A 105N
6	Bonnet Bolt	4	ASTM A 193 GR.B7M
7	Gland Studs	2	ASTM A 193 GR. B7M
8	packing Flange	1	ASTM A 276 TYPE SST.-410
9	Gland Bolt	2	ASTM A 193 GR.B7M
10	Gland Flange	1	ASTM A 105 N
11	Nut	2	ASTM A 194 GR.2HM
12	Stem Nut	1	ASTM A 276 TYPE SST.-410
13	Hand Wheel Nut	1	ASTM A 194.GR. 2HM
14	Name Plate	1	Stainless Steel
15	hand Wheel	1	MI / Sgiron
16	Packing	1 Group	Graphite
17	Washer	1	A 267 - 410



# Globe valve - Flange class 150/300/600

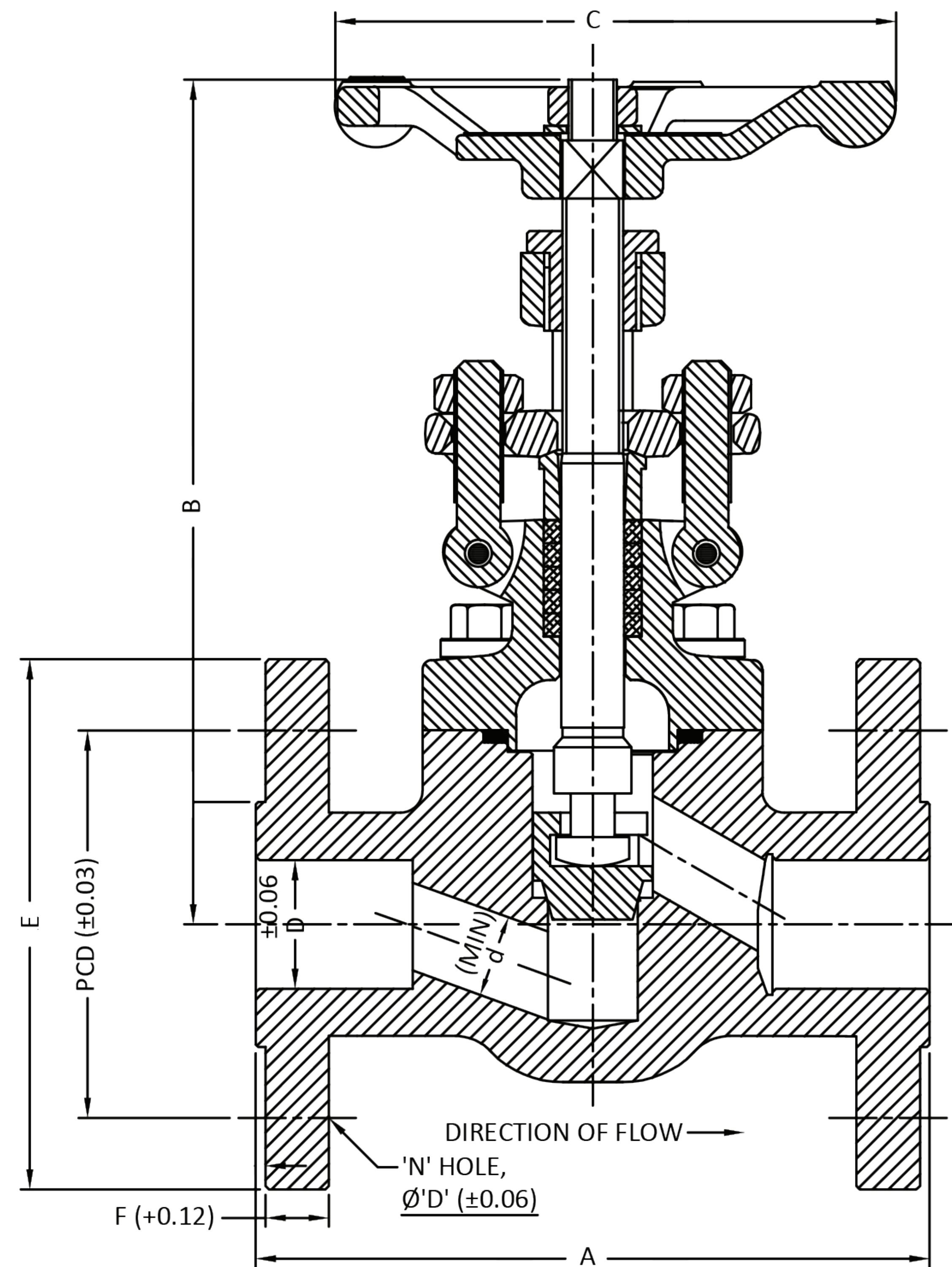

## DIMENSIONS (INCHES) CLASS 150

SIZES	A	D	d	E	F	N	ØD	PCD	C	B
1/2"	4.25	0.62	0.37	3.54	0.31	4	0.63	2.37	3.39	6.26
3/4"	4.62	0.82	0.50	3.94	0.35	4	0.63	2.73	3.39	6.50
1"	5.00	1.05	0.69	4.33	0.38	4	0.63	3.13	4.57	7.56
1 1/4"	5.50	1.38	0.94	4.53	0.44	4	0.63	3.50	4.57	7.76
1 1/2"	6.50	1.61	1.13	4.92	0.50	4	0.63	3.87	5.91	9.92

## DIMENSIONS (INCHES) CLASS 300

SIZES	A	D	d	ØF	FT	N	ØD	PCD	C	B
1/2"	6.00	0.62	0.37	3.74	0.50	4	0.63	2.63	3.39	6.26
3/4"	7.00	0.82	0.50	4.53	0.56	4	0.75	3.25	3.39	6.50
1"	8.00	1.05	0.69	4.92	0.63	4	0.75	3.50	4.57	7.56
1 1/4"	8.50	1.38	0.94	5.31	0.69	4	0.75	3.70	5.91	9.84
1 1/2"	9.00	1.61	1.13	6.10	0.75	4	0.87	4.50	5.91	9.92

## DIMENSIONS (INCHES) CLASS 600

SIZES	A	D	d	ØF	FT	N	ØD	PCD	C	B
1/2"	6.50	0.62	0.37	3.74	0.56	4	0.63	2.63	3.39	6.26
3/4"	7.50	0.82	0.50	4.53	0.63	4	0.75	3.25	3.39	6.50
1"	8.50	1.05	0.69	4.92	0.69	4	0.75	3.50	4.57	7.56
1 1/4"	9.00	1.38	0.94	5.31	0.81	4	0.75	3.87	5.91	9.84
1 1/2"	9.50	1.61	1.13	6.10	0.88	4	0.87	4.50	5.91	9.92



# PISTON CHECK VALVE

CLASS 150/300/600

FORGED STEEL  
BOLTED COVER  
NACE-MR-0175

Piston check valve - Flange class  
150/300/600

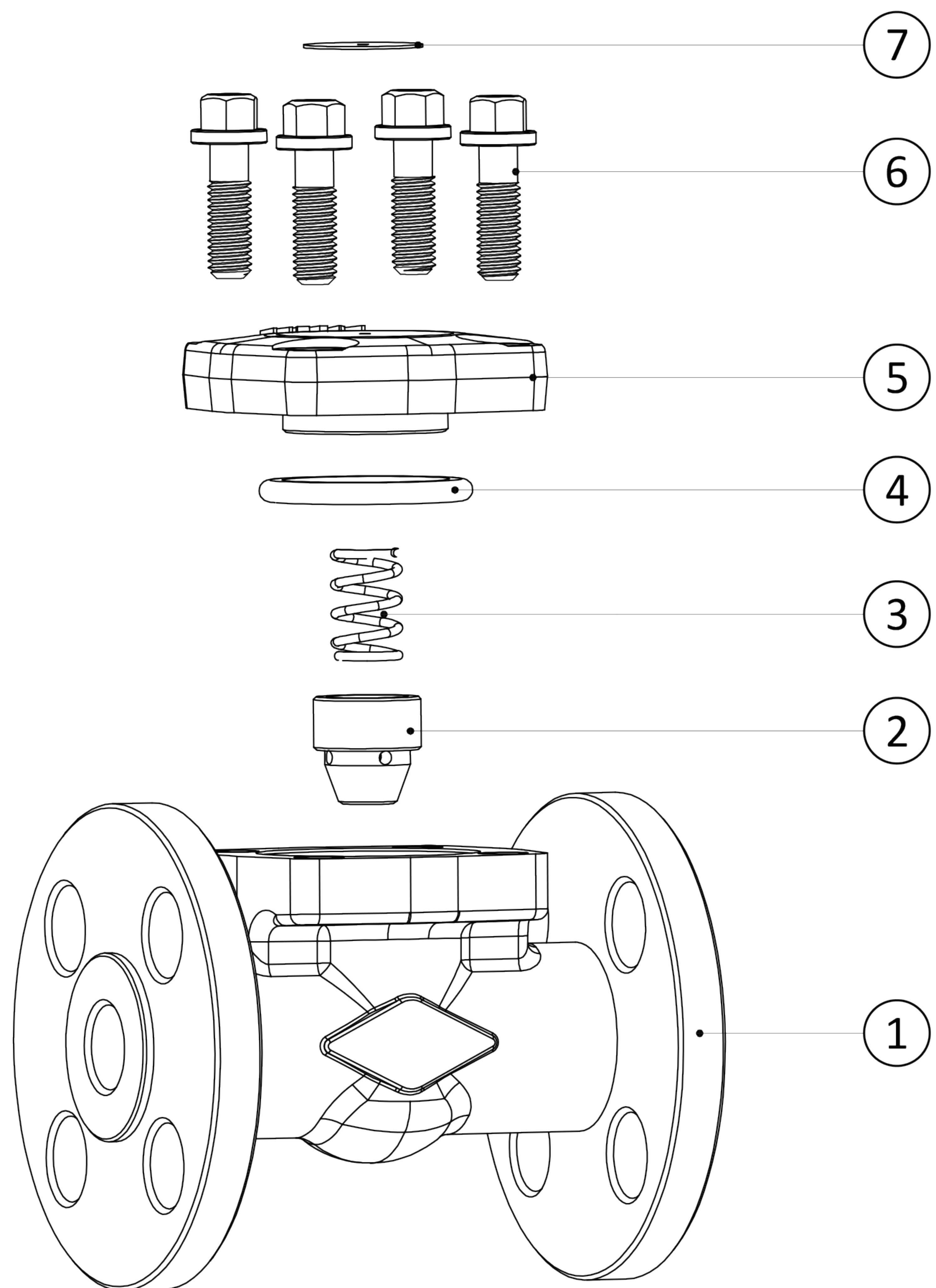

## PARTS & MATERIAL

PART NO.	PART NAME	QTY.	MATERIAL
1	Body	1	ASTM A 105 N
2	Disc	1	ASTM A 276 TYPE SS-410
3	Spring	1	INCONEL 750
4	Gasket	1	SS-316 SPIRAL WOUND+GRAPHITE
5	Cover	1	ASTM A 105N
6	Cover Bolt	4	ASTM A 193 GR. B7M
7	Name Plate	1	STAINLESS STEEL

# Piston check valve - Flange class 150/300/600

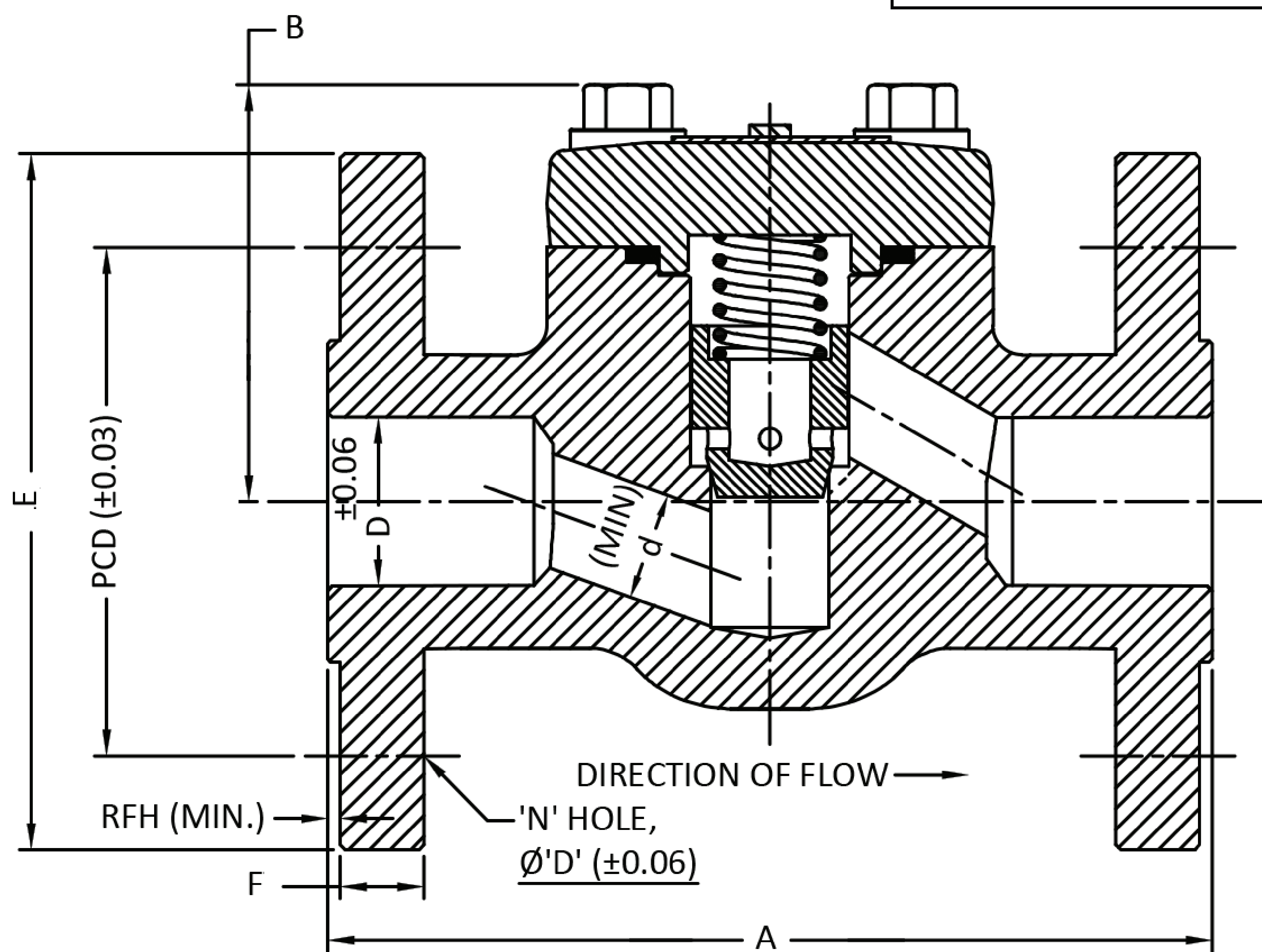

**DIMENSIONS (INCHES) CLASS 150**

SIZES	A	D	d	E	F	N	ØD	PCD	B
1/2"	4.25	0.62	0.37	3.54	0.31	4	0.63	2.37	2.06
3/4"	4.61	0.82	0.50	3.94	0.35	4	0.63	2.73	2.20
1"	5.50	1.05	0.69	4.33	0.38	4	0.63	3.13	2.60
1 1/4"	5.50	1.38	0.94	4.53	0.56	4	0.62	3.50	2.58
1 1/2"	6.50	1.61	1.13	4.92	0.50	4	0.63	3.87	3.39

**DIMENSIONS (INCHES) CLASS 300**

SIZES	A	D	d	øF	FT	N	ØD	PCD	B
1/2"	6.00	0.62	0.37	3.74	0.50	4	0.63	2.63	2.09
3/4"	7.00	0.82	0.50	4.53	0.56	4	0.75	3.25	2.20
1"	8.00	1.05	0.69	4.92	0.63	4	0.75	3.50	2.60
1 1/4"	8.50	1.38	0.94	5.31	0.69	4	0.75	3.70	3.58
1 1/2"	9.00	1.61	1.13	6.10	0.75	4	0.87	4.50	3.39

**DIMENSIONS (INCHES) CLASS 600**

SIZES	A	D	d	E	F	N	ØD	PCD	B
1/2"	6.50	0.62	0.37	3.74	0.56	4	0.63	2.63	2.09
3/4"	7.50	0.82	0.50	4.53	0.63	4	0.75	3.25	2.20
1"	8.50	1.05	0.69	4.92	0.69	4	0.75	3.50	2.60
1 1/4"	9.00	1.38	0.94	5.31	0.81	4	0.75	3.87	3.58
1 1/2"	9.50	1.61	1.13	6.10	0.88	4	0.87	4.50	3.39



# GATE VALVE 150/300/600

## APPLICABLE STANDARDS

BASIC DESIGN	API 602 /ISO 15761
FACE TO FACE DIMENSIONS	ASME B16.10
TEST	API 598
FLANGE END STANDARD	ASME B16.5

## CLASS 150

SIZE	CV	WEIGHT (LBS)
1/2"	4.50	6.00
3/4"	11.00	7.50
1"	26.00	11.25
1 1/4"	54.00	11.50
1 1/2"	79.00	21.25

## CLASS 300

SIZE	CV	WEIGHT (LBS)
1/2"	4.50	7.50
3/4"	11.00	10.50
1"	26.00	15.00
1 1/4"	54.00	16.00
1 1/2"	79.00	27.50

## CLASS 600

SIZE	CV	WEIGHT (LBS)
1/2"	4.50	8.00
3/4"	11.00	12.00
1"	26.00	17.00
1 1/4"	54.00	27.00
1 1/2"	79.00	31.00

# GLOBE VALVE 150/300/600

## APPLICABLE STANDARDS

BASIC DESIGN	API 602 /ISO 15761
FACE TO FACE DIMENSIONS	ASME B16.10
TEST	API 598
FLANGE END STANDARD	ASME B16.5

## CLASS 150

SIZE	CV	WEIGHT (LBS)
1/2"	2.20	6.00
3/4"	2.30	7.50
1"	6.00	11.00
1 1/4"	13.00	12.00
1 1/2"	15.25	21.50

## CLASS 300

SIZE	CV	WEIGHT (LBS)
1/2"	2.20	8.00
3/4"	2.30	11.00
1"	6.00	16.50
1 1/4"	13.00	25.50
1 1/2"	15.25	31.00

## CLASS 600

SIZE	CV	WEIGHT (LBS)
1/2"	8.00	8.00
3/4"	11.70	12.00
1"	17.30	17.50
1 1/4"	27.40	27.50
1 1/2"	31.70	32.00

# PISTON CHECK VALVE 150/300/600

## APPLICABLE STANDARDS

BASIC DESIGN	API 602 /ISO 15761
FACE TO FACE DIMENSIONS	ASME B16.10
TEST	API 598
FLANGE END STANDARD	ASME B16.5

## CLASS 150

SIZE	CV	WEIGHT (LBS)
1/2"	2.00	4.75
3/4"	2.90	6.50
1"	6.20	9.25
1 1/4"	10.00	11.00
1 1/2"	15.00	18.00

## CLASS 300

SIZE	CV	WEIGHT (LBS)
1/2"	2.00	7.00
3/4"	2.90	10.00
1"	6.20	14.50
1 1/4"	10.00	22.00
1 1/2"	15.00	27.75

## CLASS 600

SIZE	CV	WEIGHT (LBS)
1/2"	2.00	7.25
3/4"	2.90	10.75
1"	3.20	15.00
1 1/4"	10.00	24.00
1 1/2"	15.00	28.50



# HOW TO ORDER

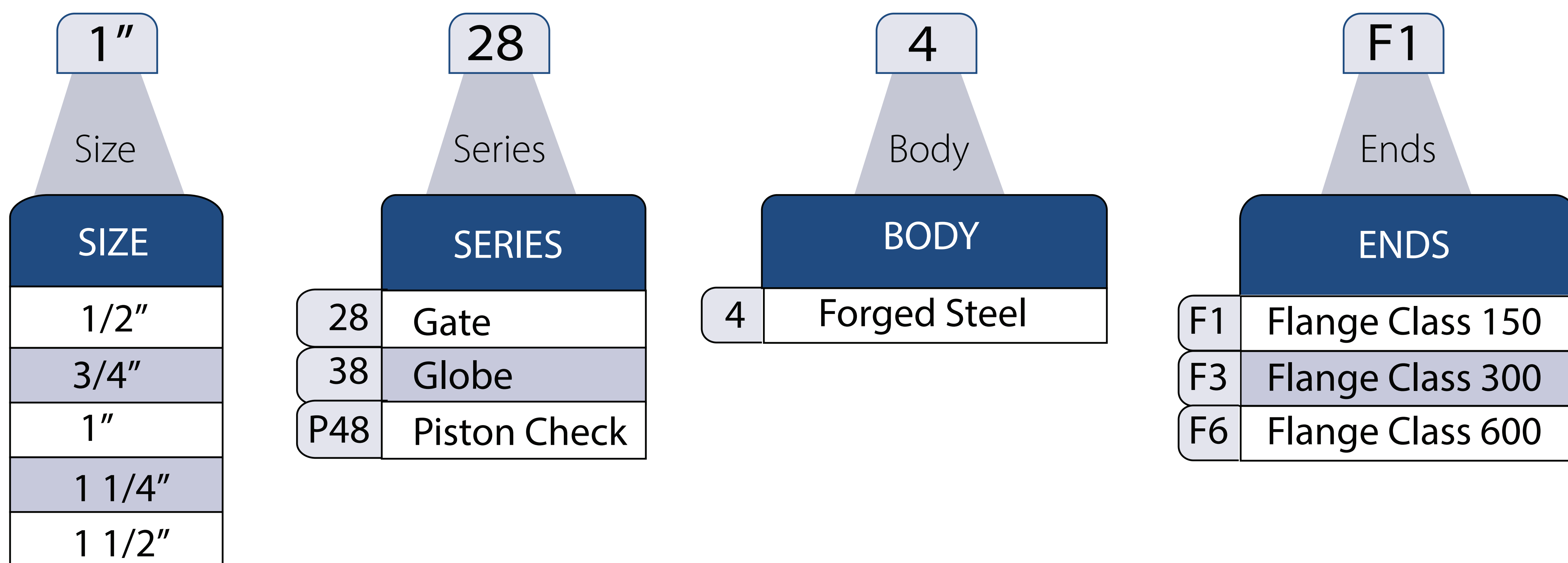

		Toll-Free (833) 831-2312
		Local (312) 637-3557
E-mail: <a href="mailto:sales@chicagovalves.com">sales@chicagovalves.com</a> <a href="http://www.chicagovalves.com">www.chicagovalves.com</a> 885 Cambridge Dr. Elk Grove Village, Illinois 60007 U.S.A		

Due to ongoing development of our product line, specifications subject to change without notice.  
 Teflon\* is a registered trademark of E.I. DuPont.

Rev. 11/17