





Tek-Flux 1400A



Quick Start Guide

1. Before you begin

Before installation check the model, specifications, and installation location for the transmitter. Follow the full User Guide for detailed installation and other information.

-  Verify that the operating atmosphere of the flow tube and transmitter is consistent with the appropriate hazardous locations certifications
-  Do not remove the transmitter cover in explosive atmospheres when the circuit is alive
-  Before connecting a HART-based communicator in an explosive atmosphere, make sure the instruments in the loop are installed in accordance with intrinsically safe or non-incentive field wiring practices
-  Make sure only qualified personnel perform the installation
-  Do not perform any service other than those contained in this manual unless qualified

2. Unpack

Tek-Flux 1400A Electromagnetic Flow Meter

3. Meter Handling

All parts should be handled carefully to prevent damage. Whenever possible, transport the system to the installation site in the original shipping containers. The flow tube is shipped with end covers to protect it from mechanical damage and normal unrestrained distortion. End covers should not be removed until just before installation. Keep shipping plugs in conduit connections until conduits are connected and sealed.

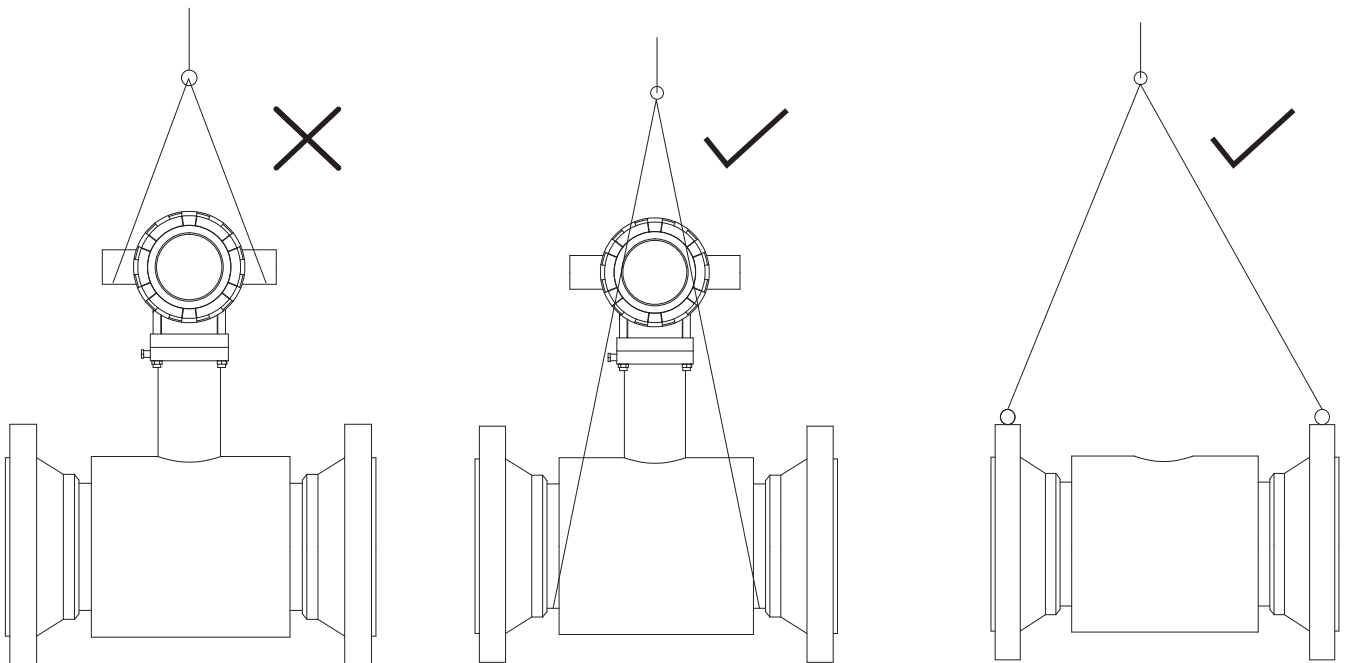

4. Dimensions

Note: For additional dimensions, refer to the detailed manual.

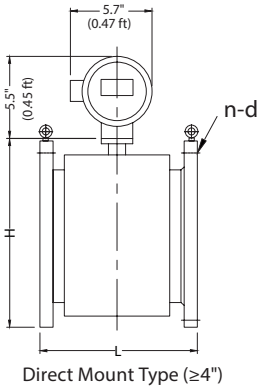

Direct Mount Type ($\geq 4"$)

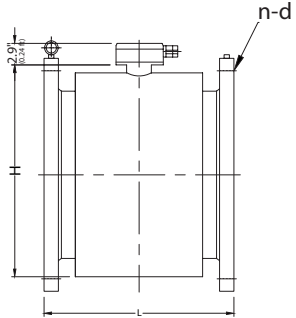

Remote Mount Type ($\geq 4"$)

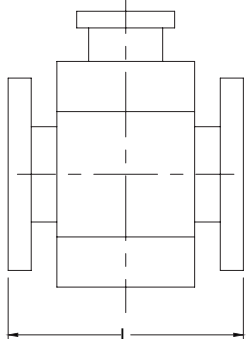

Sensor ($\frac{1}{2}"$ to $3"$)

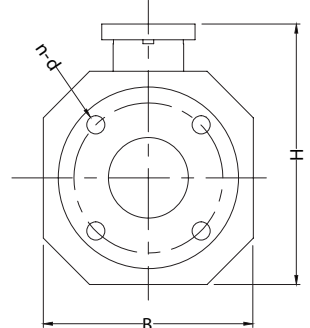

Sensor ($\frac{1}{2}"$ to $3"$)

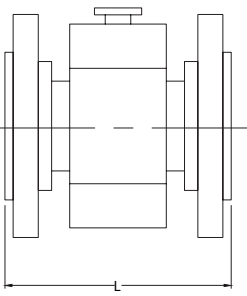

Outline dimension of medium and High Pressure Sensor

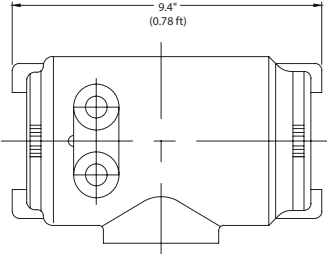
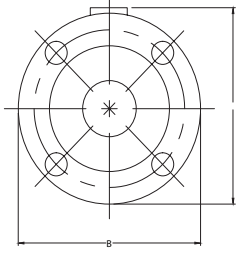

Direct Mount Transmitter

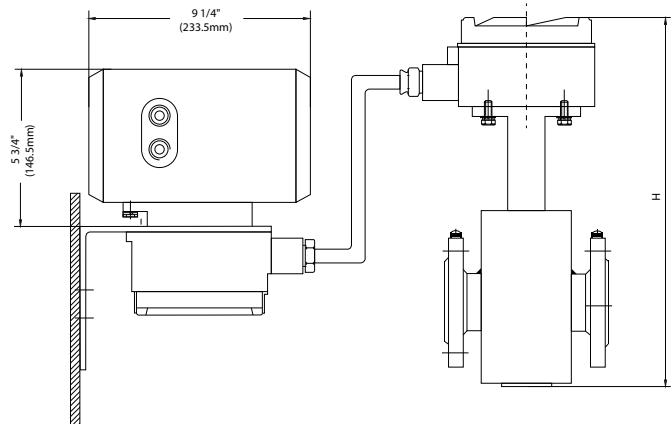
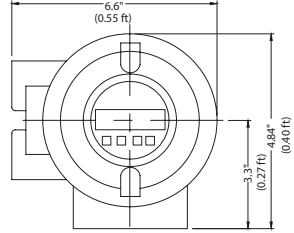

Remote Type

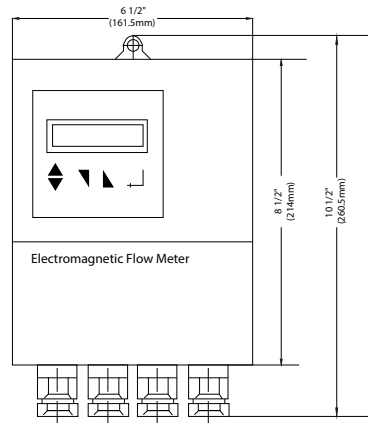

Square Type

Quick Start Guide

5. Display

Tek-Flux 1400A has a two-line backlit LCD display which measures forward and reverse flow and is used to set parameters, password, menu control, and memory function.

Display for direct mount transmitter

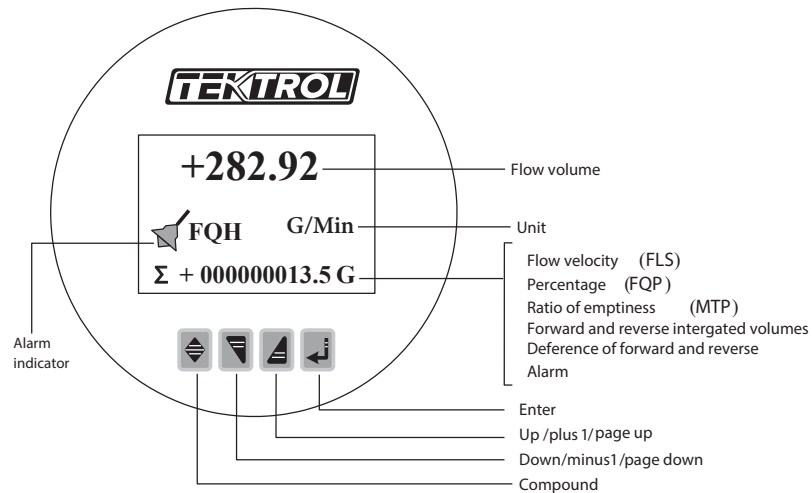

Display for remote type transmitter

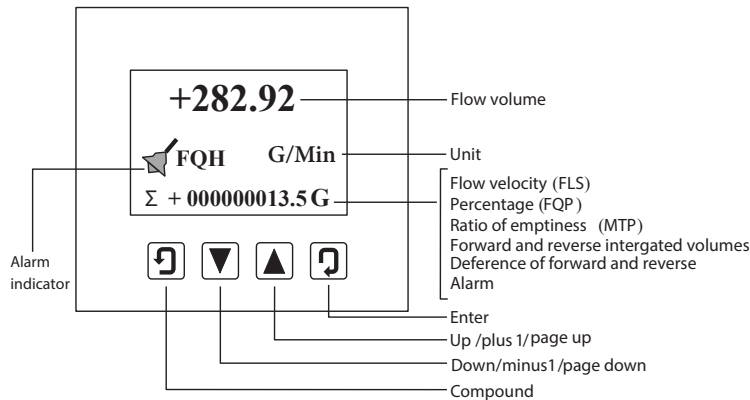

Key function for self testing

Down	Selecting displayed data in lower lines
Up	Selecting displayed data in higher lines
Enter	Press it to come into the interface
Compound & Enter	To enter parameter setting

Key functions for parameter setting

Down	Subtract 1 from the number above cursor
Up	Plus 1 to the number above cursor
Compound & Down	To shift cursor to left
Compound & Up	To shift cursor to right
Enter	To enter or exit the submenu

Note: When using "Compound" key, you should press "Compound" key and "Up" or "Down" simultaneously

6. Power Supply wiring

Wiring for direct mount transmitter

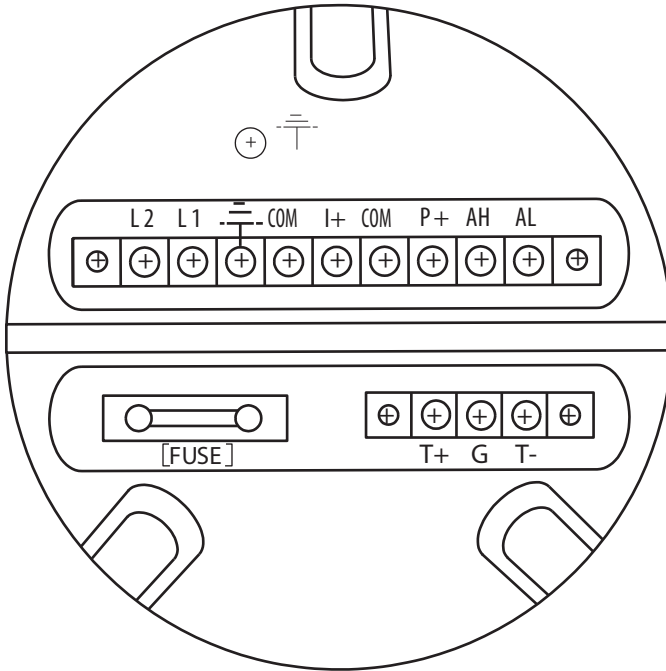

I+	Output Current for Flow Measurement
COM	Output Current (Ground) for Flow Measurement
P+	Frequency(Pulse) Output for Bi-directional Flow
COM	Frequency (Pulse) Output (Ground)
AL	Alarm Output for Low Limit
AH	Alarm Output for Upper Limit
COM	Alarm Output (Ground)
FUSE	Fuse for Power Supply
T+	+Communication Input Signal
T-	-Communication Input Signal
G	RS232 Communication Ground
L1	220V(24V) Power Supply
L2	220V(24V) Power Supply

Quick Start Guide

Wiring for remote type transmitter

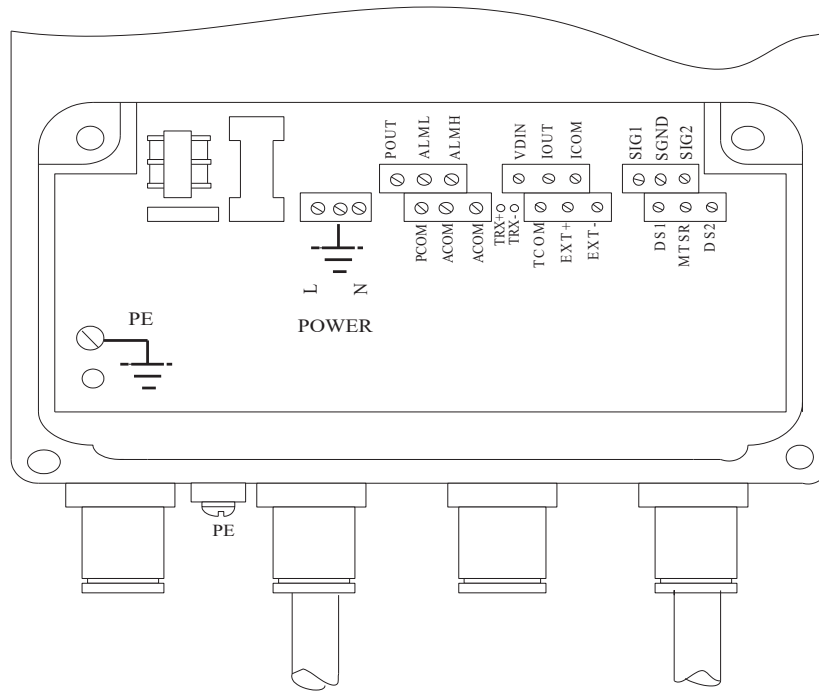

To the mounting sensor	SIG1	Signal1
	SGND	Signal Ground
	SIG2	Signal2
	DS1	Shielded Exciting1
	DS2	Shielded Exciting2
	EXT+	Exciting Current+
	EXT-	Exciting Current-
Analog Current Output	VDIN	Current Two lines 24V Spots
	ICOUT	Analog Current Output
	ICCOM	Analog Current Output Ground
Frequency (Pulse) Output	POUT	Flow Frequency (Pulse) Output
	PCOM	Frequency (Pulse) Output Ground
Two Alarm Outputs	ALMH	Upper Limit Alarm Output
	ALML	Low Limit Alarm Output
	ALCOM	Alarm Output Ground
Communication Input	TRX+	Communication Input
	TRX-	Communication Input
	ALCOM	232 Communication Ground

 Cable should be no more than 328 ft to prevent accuracy and interference. transmitter should be installed closely to sensor as much as possible.

Note: For remote type flow meter, when flow conductivity is more than $50\mu\text{S}/\text{cm}$, flow signal cable should be shield signal cable with polyvinyl chloride jacket and metal net; when flow conductivity is less than $50\mu\text{S}/\text{cm}$ or the signal is transmitted for long distance, double shield signal cable with equipotential double cores should be used.

7. Grounding

If flow meter is installed in a metal pipeline, there should be no insulating coating on pipeline in wall.

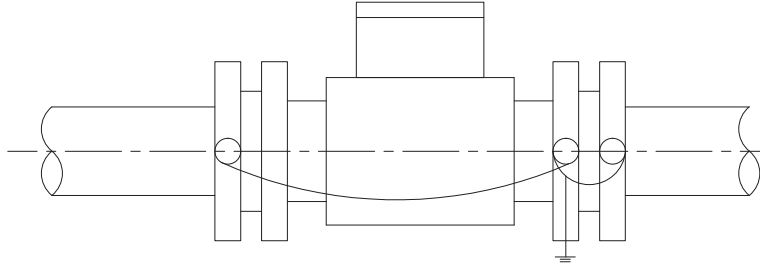

If flow meter is installed in a pipeline with insulating paint, grounding rings should be used on the sensor for both sides.

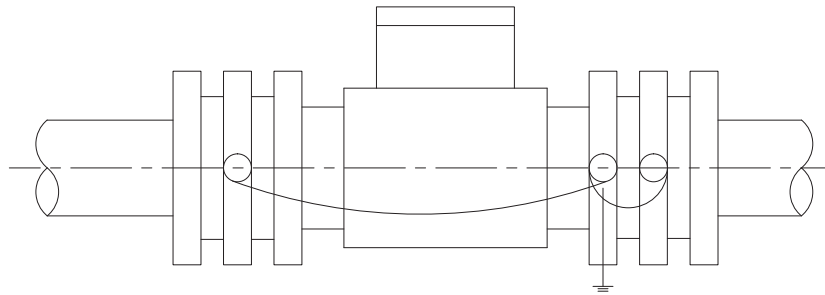

If flow meter is installed in a pipeline with cathodic protection, with inner and outer surface insulated, then the grounding rings and flange should be insulated as well.

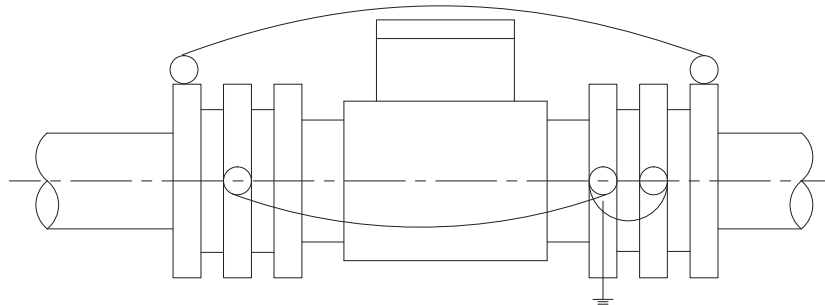

Quick Start Guide

Note: flow meter sensor part should have separate grounding cable, whose sectional area of copper core should be 1.72 ft^2 , ground resistance should be $<10\Omega$.

8. Mounting of flow meter

The correct mounting point is important to flow meter use. Mounting the meter wrong may influence measuring accuracy, life of meter, or may cause damage
The axis for measuring electrode shall be approximate to horizontal direction (included angle with horizontal line shall be no more than 10°)

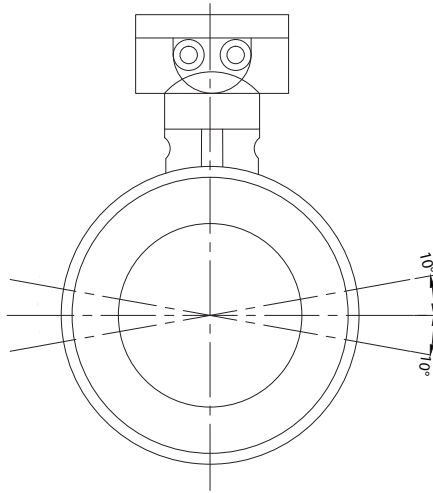

9. Installation

At upstream side of the flow meter, there should be straight pipe no less than $5D$ and no less than $2D$ at flow meter downstream.

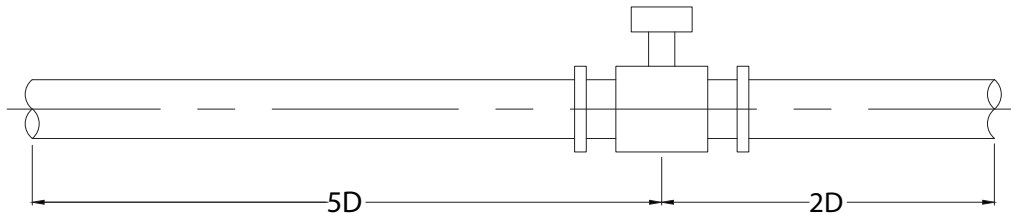

Install flow meter at relative low of horizontal pipe or in upward vertical direction. Do not install the flow meter at the highest point of pipe and in the downward vertical direction.

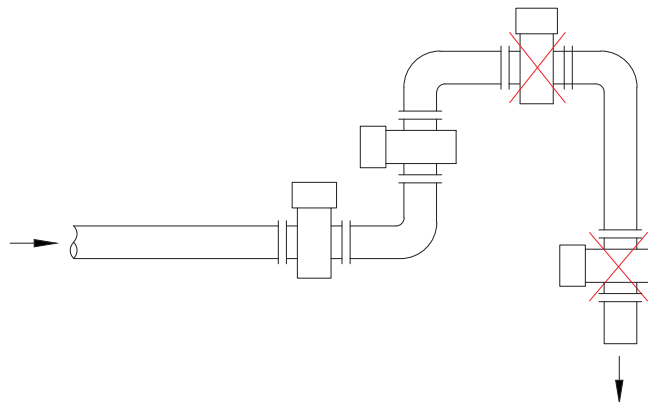

Install flow meter at the rising pipe.

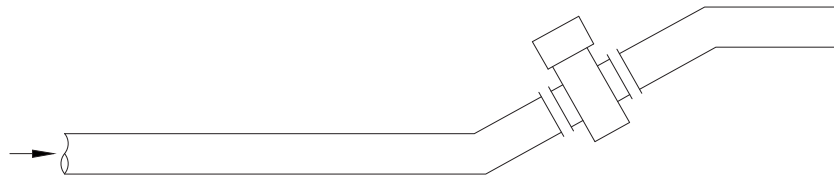

For installing at open pipe, flow meter should be installed at relative low position. If the fall in the pipe is more than 16.40 ft, vent valve should be installed at sensor downstream where it should have back pressure.

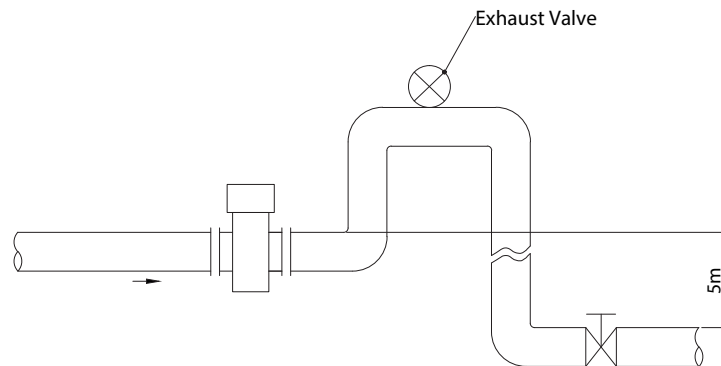

Control valve and stop valve should be installed at the downstream of sensor and not at the upstream side.

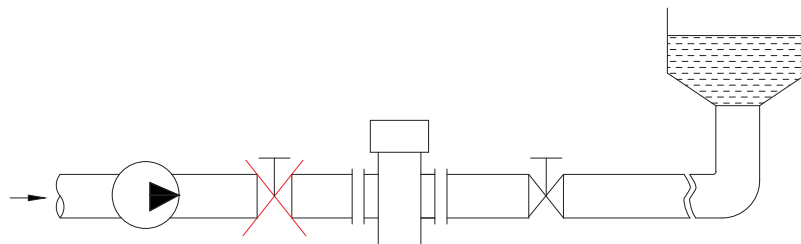

Sensor should be installed at the outlet of pump and not at the inlet.

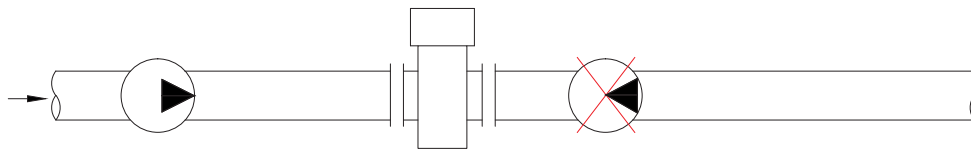

Note:

- Ensure that the pipe is filled with fluid at all times
- Flow direction of fluid shall be in accordance with arrow direction on the flow meter

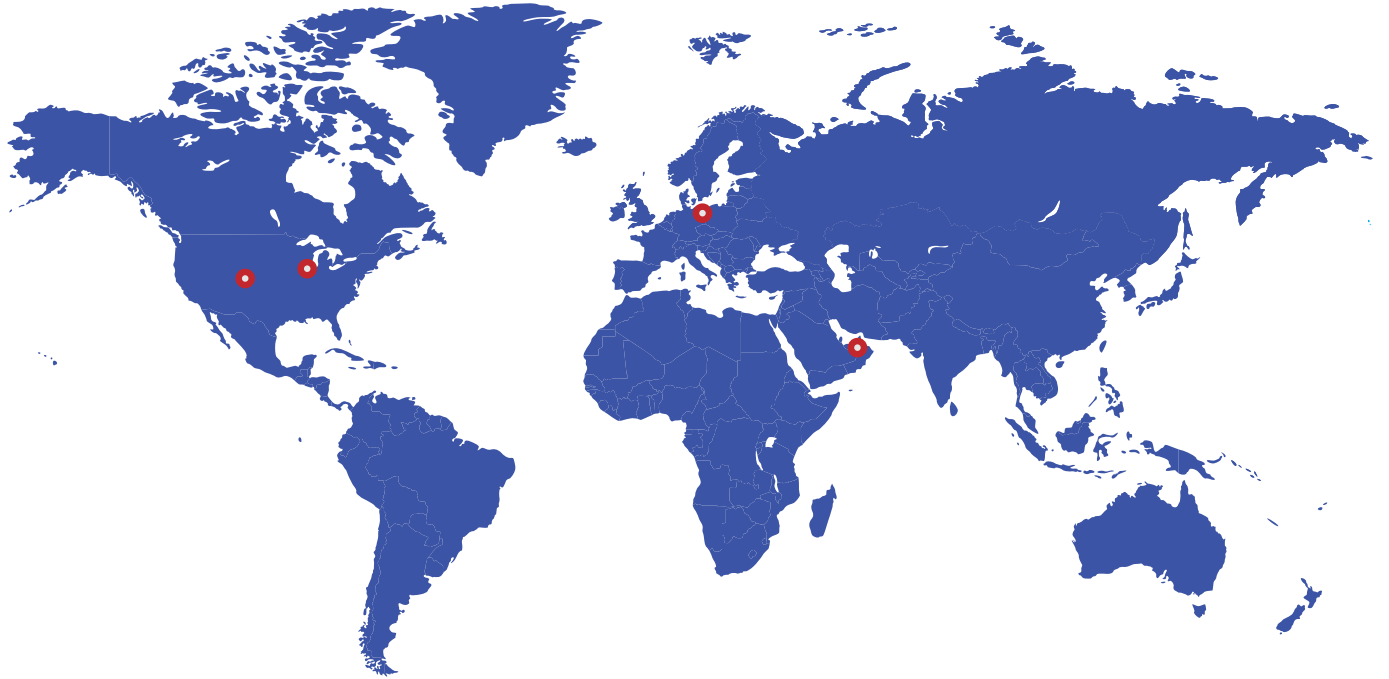

Tek-Trol LLC

796 Tek Drive Crystal Lake, IL
60014, USA
Sales: +1 847-857-6076

Tek-DPro Flow Solutions

PO Box 121 Windsor, Colorado
80550, USA
Sales: +1 847-857-6076

Tek-Trol Solutions BV

Florijnstraat 18, 4879 AH
Etten-Leur, Netherlands
Sales: +31 76-2031908

Tek-Trol Middle East FZE

SAIF Zone, Y1-067, PO BOX No.
21125, Sharjah, UAE
Sales: +971-6526-8344

Support: +1 847-857-6076

Email: tektrol@tek-trol.com

www.tek-trol.com
