



TEK-CLAMP 1200A

Ultrasonic Clamp-On Flow Meter

Instruction Manual

Document Number: IM-1200A



www.tek-trol.com

NOTICE

Read this manual before working with the product. For personal and system safety, and for optimum product performance, make sure you thoroughly understand the contents before installing, using, or maintaining this product.

For technical assistance, contact

Customer Support

796 Tek-Drive

Crystal Lake, IL 60014

USA

Tel: +1 847 857 6076

© **COPYRIGHT Tek-Trol LLC 2021**

No part of this publication may be copied or distributed, transmitted, transcribed, stored in a retrieval system, or translated into any human or computer language, in any form or by any means, electronic, mechanical, manual, or otherwise, or disclosed to third parties without the express written permission. The information contained in this manual is subject to change without notice.

Table of Contents

1	Safety Instructions	3
1.1	Intended Use	3
1.2	Safety Instructions from the Manufacturer	3
1.2.1	Disclaimer.....	3
1.2.2	Product Liability and Warranty	4
1.2.3	Information Concerning the Documentation.....	4
1.3	Safety Precautions	4
1.4	Packaging, Transportation and Storage.....	5
1.4.1	Packaging.....	5
1.4.2	Transportation.....	5
1.4.3	Storage	5
1.4.4	Nameplate.....	6
2	Product Description	6
2.1	Introduction	6
2.2	Measuring Principle	6
2.3	Specifications.....	8
2.4	Dimensional Drawing of Tek-Sonic 1200A-100F1.....	9
2.4.1	Dimensional Drawing of Tek-Sonic 1200A-100F1 S2 & M2 Sensor	10
2.5	Dimensional Drawing of Tek-Sonic 1200A-100EXP.....	10
2.6	Model Chart.....	11
3	Installation	12
3.1	Selection of Installation Place.....	12
3.2	Installation of the Wall Mount Enclosure	12
3.3	Installation of the Transducer.....	13
3.3.1	Sensors	13
3.3.1.1	Selection Of Sensor Position	13
3.3.1.2	Sensor Installation.....	14
3.3.1.3	Spacing Between the Sensors	15
3.3.2	Length of the straight pipe	16
3.3.3	Transducer Installation Method.....	18
3.3.3.1	Installation Space	20
3.3.3.2	Installation Method.....	21
3.4	Instrument Well Construction Requirements	23
3.5	Quick Pipe Parameter Setting.....	23
4	Electrical Connections	24
4.1	Basic Requirement	24
4.2	Power Supply and Signal Wiring Diagram of 1200A-100F1 Enclosure	24
4.2.1	Keypad.....	25
4.2.2	Menu Windows	25
4.2.3	Menu Window List	26
4.3	Power Supply and Signal Wiring Diagram of 1200A-100M	27
4.4	Power Supply and Signal Wiring Diagram of 1200A-100EXP.....	29
4.5	Transducer Wiring Diagram	29
4.6	Installation Check-Up	30
4.6.1	Signal Strength (S)	30
4.6.2	Signal Quality (Q).....	30
4.6.3	Total Transit Time and Delta Time	30
4.6.4	Transit Time Ratio	30
5	Operation	31

5.1	Menu Window Details.....	32
5.2	Work parameter solidification of the Flow meter and option indication	36
5.3	Zero-Point Setup and Zero-Point Solidification.....	36
5.4	Factory Use of the Scaling Factor Solidification	37
5.5	Analog Calculating Function Application	37
5.6	Analogue Input Interface as Digital Input Interface: Method and Introduction.....	37
5.7	Introduction of Serial Peripheral Extension Interface	37
5.8	Realize Medium Identifying Function.....	37
5.9	Restoring the Flow meter to Factory Default.....	37
6	Totalizer reset.....	38
7	BTU settings.....	38
8	Maintenance.....	38
8.1	Maintenance Service.....	38
8.2	Software Upgrade Service	39
8.3	Important Notice for Product Return	39
9	Troubleshooting.....	39
9.1	Error Messages After Switching On.....	41
9.2	Further Errors and Countermeasures.....	41
9.3	Further Errors and Countermeasures.....	42
10	Appendix	43
10.1	Tables: Pipe Size	43
10.1.1	Copper - Standard Pipe Size Charts:	43
10.1.2	PVC - Standard Pipe Size Charts:.....	44
10.1.3	Steel - Standard Pipe Size Charts:	45
10.1.4	Cast Iron Pipe - Standard Pipe Size Charts:.....	49
10.1.5	Ductile Iron Pipe - Standard Pipe Size Charts:	49
10.2	Tables: Sound Speed	50
10.2.1	Solids: Sound Speed Data	50
10.2.2	Water: Sound Speed	51
10.2.3	Liquids: Sound Speed	52

1 Safety Instructions

1.1 Intended Use

Tek-Clamp 1200A is an Ultrasonic Clamp-on Flow meter are used only for measuring the flow of liquids in closed pipes, e.g.: clean water, wastewater etc.

The manufacturer is not liable for damage caused by improper or non-designated use.

1.2 Safety Instructions from the Manufacturer

This meter was calibrated at the factory before shipment. To ensure correct use of the meter, please read this manual thoroughly.

- The device must only be used within the approved temperature range:
 - a) Environmental humidity max. <80 % RH
 - b) Environmental temperature 0 ... 158 °F
- Do not expose the device to extreme temperatures, direct sunlight, extreme humidity, condensation, or moisture.
- With wet hands never use the instrument.
- Before taking a measurement, the device should be stabilised to the ambient temperature (important when carrying the device from cold to warm rooms and vice versa).
- Avoid strong electrical shocks.
- Do not use the meter around corrosive or explosive gases.
- The case should only be opened by qualified Tek-Trol LLC personnel.
- Repairs and maintenance work may only be carried out by qualified Tek-Trol LLC personnel.
- Never place the front side of the device on a workbench or work surface to avoid damage to the operating elements.
- You must not make any technical changes to the device.
- Keep the flow meter clean and dry.
- The appliance should only be cleaned with a damp cloth. Use only pH-neutral cleaner, no abrasives, or solvents.
- Non-observance of the safety notes can cause damage to the device and injuries to the user.

We do not assume liability for printing errors or any other mistakes in this manual. We expressly point to our general guaranteed terms which can be found in our general terms of business. If you have any questions, please contact Tek-Trol LLC. The contact details can be found at the end of this manual.

1.2.1 Disclaimer

The manufacturer will not be held accountable for any damage that happens by using its product, including, but not limited to direct, indirect, or incidental and consequential damages.

Any product purchased from the manufacturer is warranted in accordance with the relevant product documentation and our Terms and Conditions of Sale.

The manufacturer has the right to modify the content of this document, including the disclaimer, at any time for any reason without prior notice, and will not be answerable in any way for the possible consequence of such changes.

1.2.2 Product Liability and Warranty

The operator shall bear authority for the suitability of the device for the specific application. The manufacturer accepts no liability for the consequences of misuse by the operator. Wrong installation or operation of the devices (systems) will cause the warranty to be void. The respective Terms and Conditions of Sale, which forms the basis for the sales contract shall also apply.

1.2.3 Information Concerning the Documentation

To prevent any injury to the operator or damage to the device it is essential to read the information in this document and the applicable national standard safety instructions. This operating manual contain all the information that is required in various stages, such as product identification, incoming acceptance and storage, mounting, connection, operation, and commissioning, troubleshooting, maintenance, and disposal.

1.3 Safety Precautions

You must read these instructions carefully prior to installing and commissioning the device. These instructions are an important part of the product and must be kept for future reference. Only by observing these instructions, optimum protection of both personnel and the environment, as well as safe and fault-free operation of the device can be ensured.

For additional information that are not discussed in this manual, contact the manufacturer

Warnings and Symbols Used

The following safety symbol marks are used in this operation manual and on the instrument.



WARNING

Indicates a potentially hazardous situation which, if not avoided, could result in death or serious injury



CAUTION

Indicates a potentially hazardous situation which, if not avoided, may result in minor or moderate injury. It may also be used to alert against unsafe practices.



NOTE

Indicates that operating the hardware or software in this manner may damage it or lead to system failure.

1.4 Packaging, Transportation and Storage

1.4.1 Packaging

The original package consists of

1. Tek-Clamp 1200A-100 Ultrasonic Clamp-on Flow meter
2. Documentation



NOTE

Unpack and check the contents for damages or signs of rough handling. Report damage to the manufacturer immediately. Check the contents against the packing list provided.

1.4.2 Transportation

- Avoid impact shocks to the device and prevent it from getting wet during transportation.
- Verify local safety regulations, directives, and company procedures with respect to hoisting, rigging, and transportation of heavy equipment.
- Transport the product to the installation site using the original manufacturer's packing whenever possible.

1.4.3 Storage

The Tek-Clamp 1200A-100 is designed for installation and usage purpose in typical commercial/industrial environments. The following considerations must be observed in selecting a location for the meter:

- The ambient operating temperature range is -22°F (-30°C) to 176°F (80°C)

- Do not expose the meter to corrosive liquids or fumes
- Avoid installation locations that are close to strong sources of electrical interference
- Avoid installing the electronics enclosure in direct sunlight
- Avoid installation locations where the transducers will be exposed to vibrations in the piping system
- Always run transducer cables in a dedicated conduit separate from signal and power cables
- Allow sufficient space for daily inspection, wiring, etc.
- Avoid installing the meter at a place subjected to, or at risk of, flooding

1.4.4 Nameplate

The nameplate lists the order number and other important information, such as design details and technical data



Note

Check the device nameplate to ensure that the device is delivered according to your order. Check for the correct supply voltage printed on the nameplate.

2 Product Description

This section covers the reference and specification data, as well as ordering information.

2.1 Introduction

Tek-Clamp 1200A Ultrasonic Clamp-on Flow meter is designed to measure the velocity of liquid in a full/closed pipe. It operates according to the difference in the Transit Time of Flight measured and determines the flow velocity by measuring the travel time of a pulse from one transducer to the next. Electroacoustic transducers receive and emit brief ultrasonic waves through the liquid of the pipe. Transducers are vertically placed at both sides of the measured pipe and fastened by means of a clamp. The Tek-Clamp 1200A can be used for metallic, plastic and rubber tubes.

2.2 Measuring Principle

When the ultrasonic waves are transmitted through the flowing liquid, there will be a difference between the upstream and downstream transit time (travel time or time of flight), which is proportional to flow velocity. Ultrasonic waves travelling in the same direction as that of the flow takes lesser time to reach the second transducer than that of the waves which travels in the opposite direction of the flow.

The formula for calculating velocity is:

$$V = \frac{MD}{\sin 2\theta} \times \frac{\Delta T}{T_{up} \times T_{down}}$$

Where,

θ is the include angle to the flow direction

M is the number of times that the ultrasonic beam travels

D is the pipe diameter

T_{up} is the time for the beam to travel from upstream transducer to the downstream

T_{down} is the time for the beam to travel from downstream transducer to the upstream

$$\Delta T = T_{up} - T_{down}$$

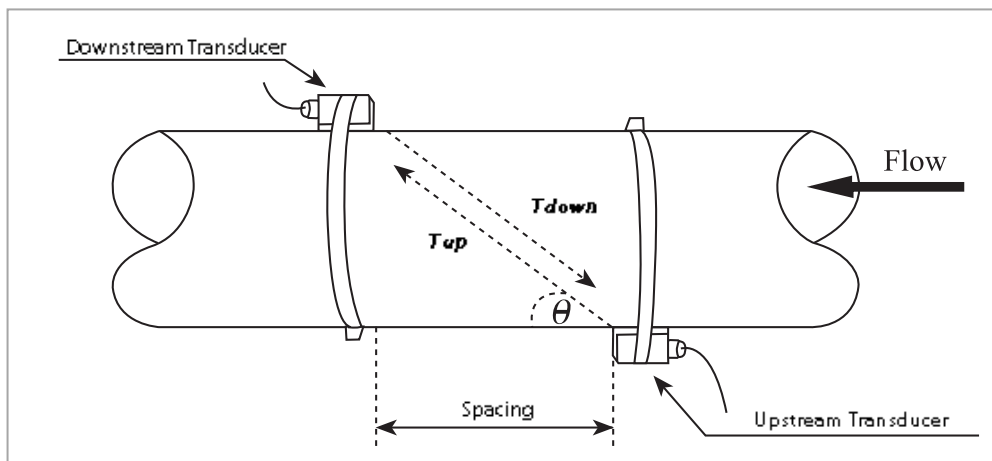

Fig 1: Tek-Clamp 1200A-100H Handheld Ultrasonic Flow Meter

The Tek-Clamp 1200A-100H has been developed to measure the flow velocity of liquids in pipes. The non-contact transducers/sensors are placed on the pipes and thus not subject to wear and tear. The Tek-Clamp 1200A-100H works with two signal transducers (sensors) that serve as ultrasonic transmitters and ultrasonic receivers. The sensors are installed on the outer wall of the pipe at a defined distance, one below the other. The sensors can be installed in Z shape (Z method). In this case, the ultrasound will pass through the pipe once. The ultrasound will pass through the pipe four times if the sensors are installed in W shape (W method). When using the Z method, the sensors are placed opposite to each other. The sound passes through the pipe or liquid diagonally. The selection of the right method depends on the characteristics of the liquid.

2.3 Specifications

Parameters		Specifications	
Accuracy		±1% of Reading	
Velocity		±0.03 to ±100 ft/s (±0.01 to ±30m/s)	
Repeatability		0.2%	
Measurement Period		0.5 Seconds	
Measurement Principle		Transit-time measurement principle	
Display		LCD with backlight. 2 x 20 letters	
Media		All liquids with solids of <5 % and a flow of >0.19pm	
Main Unit	Flow Units	Cubic	m ³
		Liter	l
		Gallon	gal
		Imperial Gallon (UK)	igl
		Million USA Gallons	mgl
		Cubic foot	cf
		Barrel (USA)	bal
		Imperial Barrel (UK)	ib
		Oil Barrel	ob
Output	100F1	Modbus RS485, 4-20 mA, Pulse	
	100M	Modbus RS485, 4-20 mA, Pulse	
	100EXP	Modbus RS485, 4-20 mA, Pulse	
Input		Two three wire system PT100 platinum resistor input loop. For BTV process monitoring	
Other Functions		Automatically stores the memory of the positive, negative, net totalizer flow rate and heat quantity of the last 512 days, 128 months, 10years	
Power	100F1	85 to 264VAC or 8 to 36VDC	
	100M	8 to 36VDC	
	100EXP	8 to 36VDC	
Power Consumption		Less than 1.5W	
Environment Temperature		-22 °F to 176 °F (-30 °C to 80 °C)	
Environment Humidity		85% RH	
Protection Class		IP65 (Tek-Clamp 1200A-100F1) IP65; Class I Div II (Tek-Clamp 1200A-100EXP)	

Transducers	Clamp-On	S2-type: for pipe size ½" to 4" M2-type: for pipe size 2" to 28" 1200A-L2: 12" to 200" 1200A-IM: 3" to 7" 1200A-IL: 3" to 12"
	Protection Class	IP68, can work in water with depths less than 10' (3m)
Liquids	Types	Virtually all commonly used clean liquids. Liquids with small quantity of tiny particles may also be applicable. Particle size should be less than 75um, particle concentration less than 20,000ppm. Liquids should contain no or very minor air bubbles.
	Process Temperature	-40 °F to 320 °F (-40 °C to 160 °C)
Pipe	Pipe Material	All metals, most plastics, fiberglass, etc.
	Pipe Size	½" to 200"
	Pipe Straight Run	More than 10D for upstream, more than 5D for downstream, where D is pipe diameter.

2.4 Dimensional Drawing of Tek-Sonic 1200A-100F1

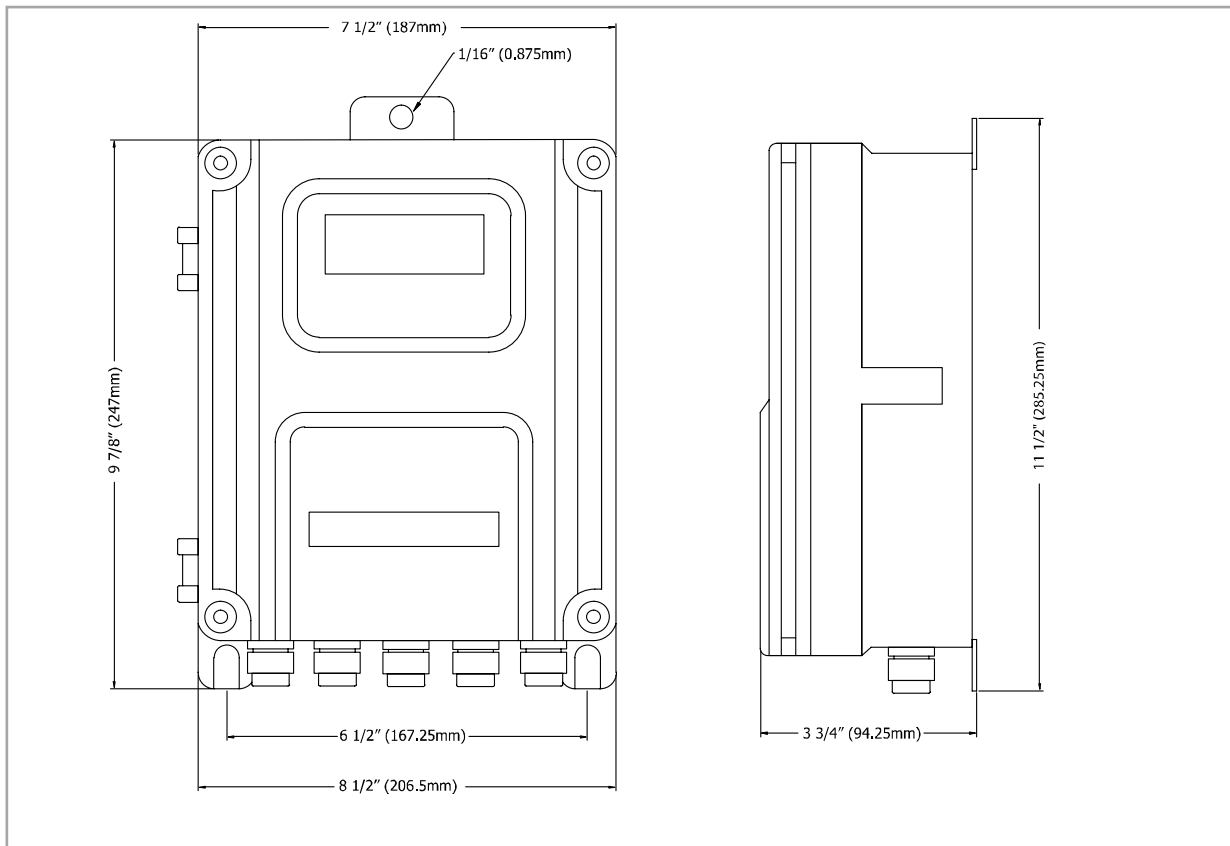

Fig 2: Tek-Sonic 1200A-100F1

2.4.1 Dimensional Drawing of Tek-Sonic 1200A-100F1 S2 & M2 Sensor

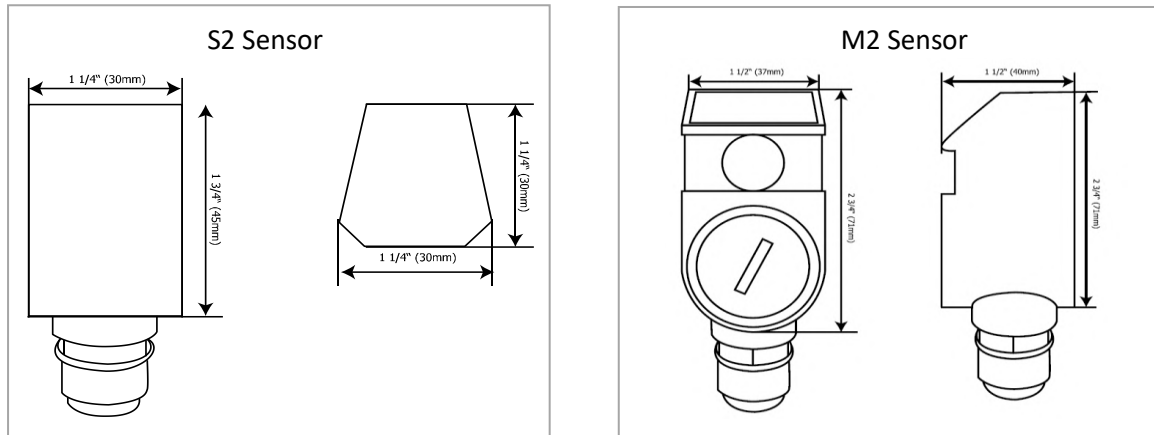

Fig 3: S2 or M2 Sensor

2.5 Dimensional Drawing of Tek-Sonic 1200A-100EXP

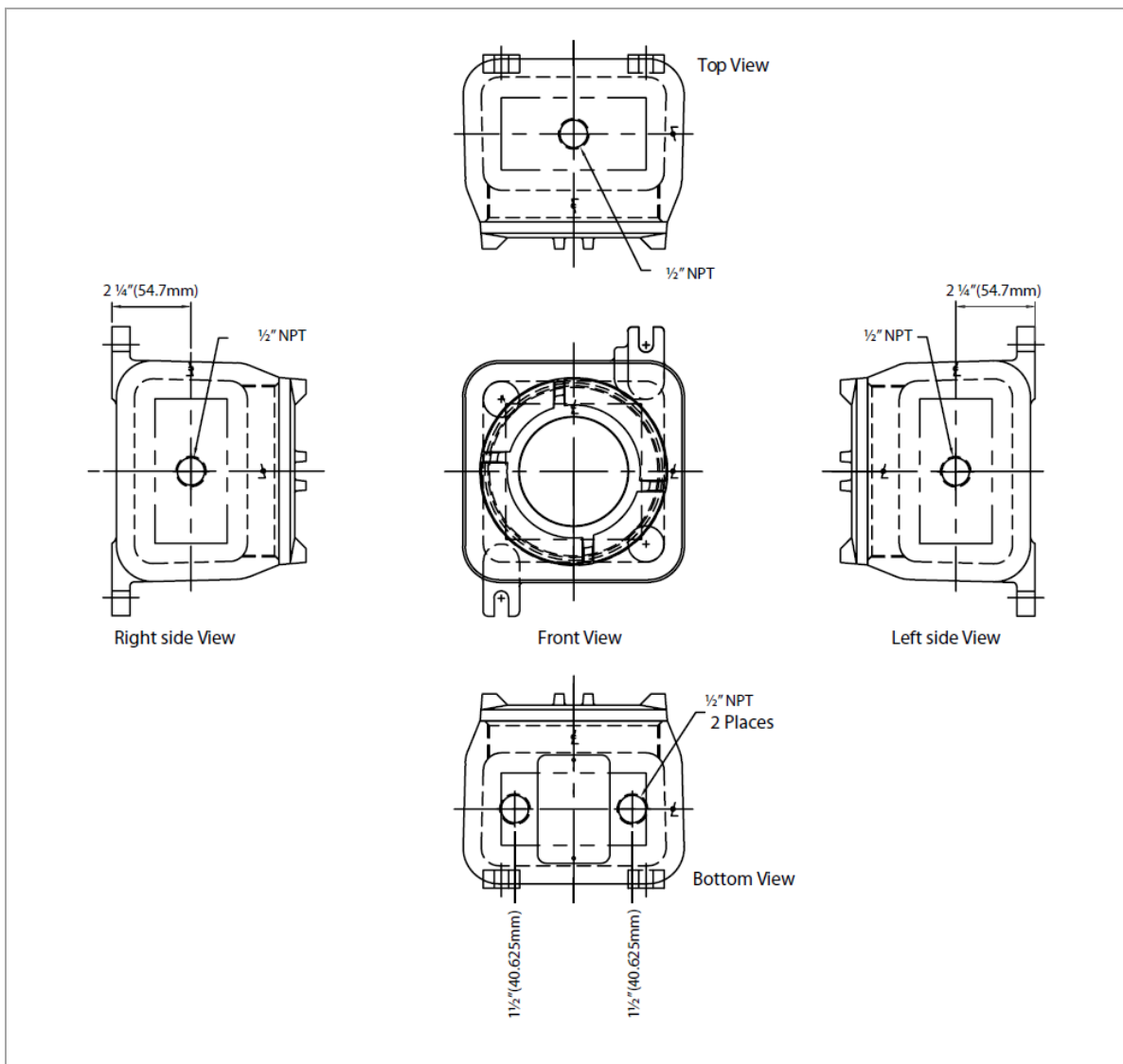
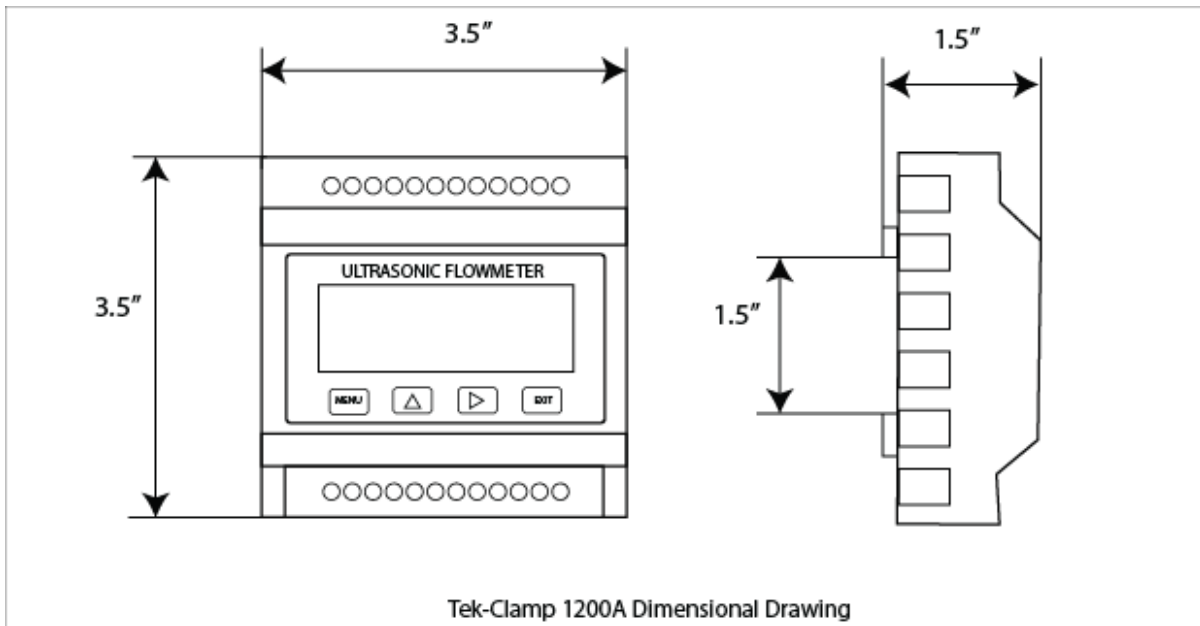

Fig 4: Tek-Sonic 1200A-100EXP



Tek-Clamp 1200A Dimensional Drawing
Fig 5: Tek-Sonic 1200A-100EXP

2.6 Model Chart

Model Number	Description
Note: Controller, Sensors, and Options are all ordered individually	
Controllers	
1200A-100F1	Wall Mount Ultrasonic Flow Meter
1200A-100M	Low-Cost DIN Mount Flow Meter
1200A-100EXP	Explosion Proof Ultrasonic Flow Meter
1200A-100H	Handheld Ultrasonic Flow Meter (with carrying case)
Transducers	
1200A-S2	½" to 4" Pipe (Wall and DIN Controller)
1200A-M2	2" to 28" Pipe (Wall and DIN Controller)
1200A-L2	12" to 200" Pipe (Wall or DIN Controller)
1200A-IM	Insertion Sensor 3" to 7" Pipe (Wall or DIN Controller)
1200A-IL	Insertion Sensor 3" to 12" Pipe (Wall or DIN Controller)
1200A-S2H	½" to 4" Pipe (Handheld)
1200A-M2H	2" to 28" Pipe (Handheld)
1200A-HSH	½" to 4" Pipe, Bracket Mounted Sensors (Handheld)
1200A-HMH	2" to 28" Pipe, Bracket Mounted Sensors (Handheld)

Accessories	
1200A-TM8812	Ultrasonic Thickness Gauge
1200A-SEYV75-2-5	Junction box and two 16' Extension Cables
1200A-BIT	Drill Bit for Insertion Sensors
1200A-Gel	Coupling Gel

***Note:** For pipe diameter greater than 1 inch with SS/Carbon steel please select M2 Transducers for better signal strength.

3 Installation

This section covers instructions on installation and commissioning. Installation of the device must be carried out by trained; qualified specialists authorized to perform such works.



CAUTION

- When removing the instrument from hazardous processes, avoid direct contact with the fluid and the meter
- All installation must comply with local installation requirements and local electrical code

3.1 Selection of Installation Place

Careful attention should be given while selecting the place of installation for system components as it will help the operators with the initial installation, reduce the start-up problems and make further installations easier.

For example: Do not install the Tek-Clamp 1200A-100F1 flow meter where it will be difficult for the personnel to perform periodic maintenance.

When selecting a site for mounting the system components, consider the criteria under Section **1.4.3. Storage**.

3.2 Installation of the Wall Mount Enclosure

- Find an easily accessible location where wire connections can be made, and flow meter readings can be taken from floor level.
- Mount the enclosure on a vibration-free surface
- Avoid sites such as the plenum of a fan coil, heat exchanger, or other housings containing motors

- Avoid mounting the enclosure in close proximity to VFD's, electric motors or other strong sources of electrical interference



NOTE

Secure at least 4" (100mm) of space between the flow transmitter and nearby wall. Also secure a space for opening the front cover for maintenance. Secure a cable wiring space under the enclosure

3.3 Installation of the Transducer

Installation of Tek-Clamp 1200A-100 series is the easiest and convenient way in the installation of all flow meters. Just choose a suitable measurement point, input the pipe parameters of this pipe point to the flow meter, and then fix the transducers on the pipe.



3.3.1 Sensors



3.3.1.1 Selection Of Sensor Position

The first step before installation should be finding a suitable position to place the sensors. This is a requirement for accurate measurement results. Some basic knowledge about the pipes / the plumbing system is necessary.

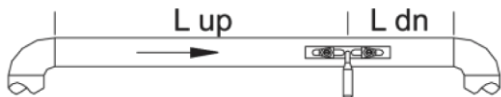
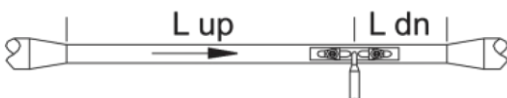
The ideal location would be an infinitely long, straight pipe, whereas there must be no entrapped air (air bubbles) in the liquid. The pipes can either run vertically or horizontally. A straight flow-calming section before and behind the measuring point should be considered to avoid inaccuracies due to turbulence in the liquid. In general, the section in front of the measuring point should be at least 10 x the pipe diameter, and after the measuring point, it should be 5 x the pipe diameter.

The following chart shows examples of good positions:

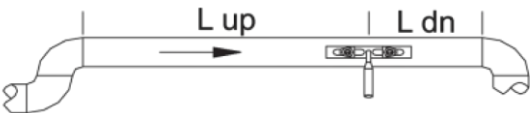
Pipe routings and sensor position	Upstream	Downstream
	$L_{up} \times \varnothing$	$L_{dn} \times \varnothing$
	10D	5D
	10D	5D
	10D	5D

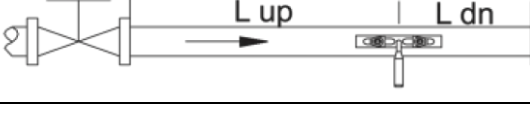
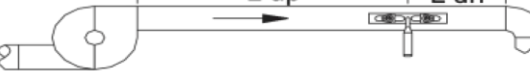
	12D	5D
	20D	5D
	20D	5D
	30D	5D

The following should be considered when looking for a good measuring position:

1. Install the sensors on a preferably long, straight pipe filled with the liquid and does not contain any air bubbles.
2. Make sure that the liquid and thus the pipe is not too hot for the sensors. The temperature should be as similar to the room temperature as possible.
3. Consider fouling of the pipes. If possible, choose a clean or new pipe for measurement. You can also clean the pipe. If this is not possible, consider the thickness of the fouling as part of the liner.
4. Some pipes have a synthetic liner. There can be a boundary layer between the outer pipe and the liner. This boundary layer can divert or weaken the ultrasonic waves, which will make a measurement very difficult. If possible, these types of pipes should be avoided. If this is not possible, sensors can also be built into the pipe

3.3.1.2 Sensor Installation

The Tek-Clamp 1200A-100H has piezoelectric sensors which can transmit and receive ultrasonic waves. The ultrasonic waves pass through the pipe walls, and the liquid allows conclusions about the flow velocity. As the transit time of the ultrasonic pulses is very short, the sensors should be installed as precisely as possible to ensure the highest system accuracy.

Take the following steps to install the sensors:

- Some pipes have a plastic liner. There can be a boundary layer between the outer diameter of the pipe and the inner liner. This boundary layer can divert or weaken the ultrasonic waves. In this case, an accurate measurement will be very difficult. If possible, these types of pipes should be avoided.
- Find an ideal position in the piping system, i.e., a straight section with new and clean pipes, if possible.
- The pipes must be clean. Grind or polish the locations where you would like to place the sensors.
- If pollution cannot be removed, its thickness should be considered part of the pipe's liner.
- There must not be an air gap between the sensors and the surface of the pipe. Attach the sensors using sufficient contact gel.

- Moreover, you should make sure there is no dust or sand between the pipe and the sensor. To avoid air bubbles from causing measurement errors, place the sensors on the pipe laterally.

3.3.1.3 *Spacing Between the Sensors*

The distance between the upstream and the downstream sensor can be seen in window M25. The window states the inner distance between the two sensors, which you should stick to as accurately as possible. The information in M25, however, must only be considered a coarse adjustment. The fine adjustment is carried out by arranging the spacing so that the time constant in M90 is exactly 100%.

To ensure accurate measurement values, the following data must be entered:

- The outer diameter of the pipe (M11)
- Material thickness of the pipe (M12)
- Material of the pipe (M14)
- The liner of the pipe (M16)
- Type of liquid (M20)
- Type of sensors connected (M23)
- The mounting method of sensors (M24)
- Check the spacing in window M25 and fix the sensors accordingly.
- During installation, ensure that the value of the time constant in M90 is 100 %, that the signal strength is >700 and that the signal quality is >60.

3.3.2 Length of the straight pipe

The length of upstream and downstream straight pipe of the ultrasonic transducer should be long enough to ensure accurate measurements.

- For 90° bend

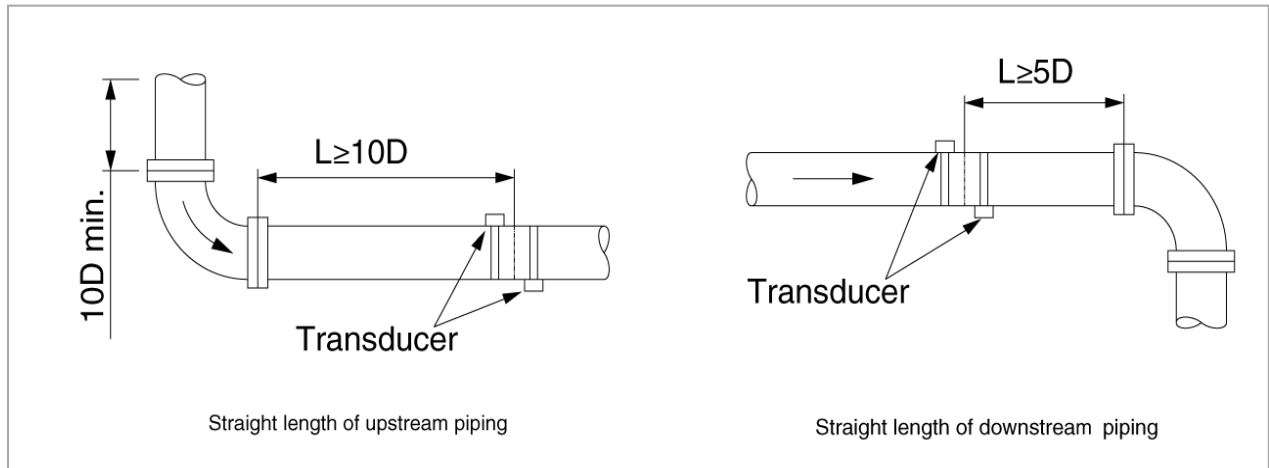

Fig 5: 90° bend pipe

- For Tee bend

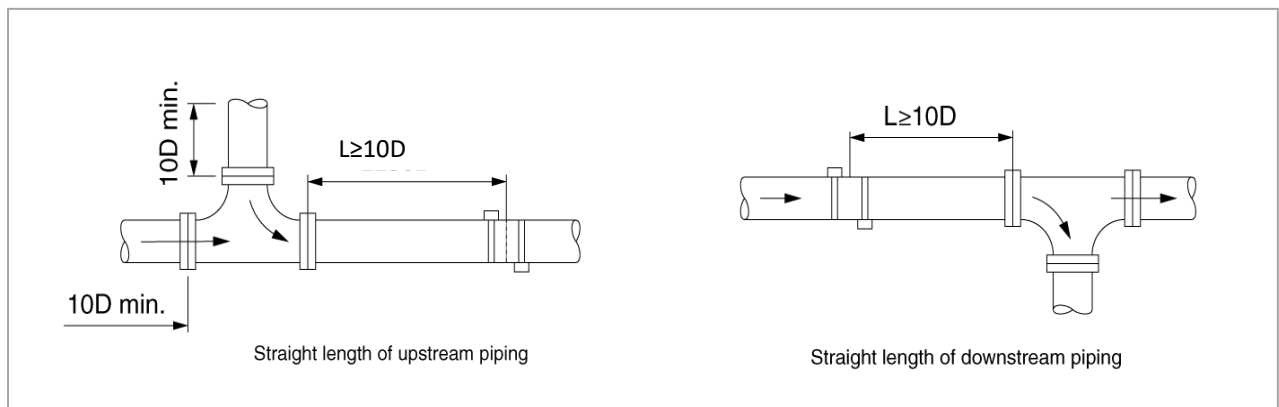

Fig 6: Tee bend pipe

- For Diffuser

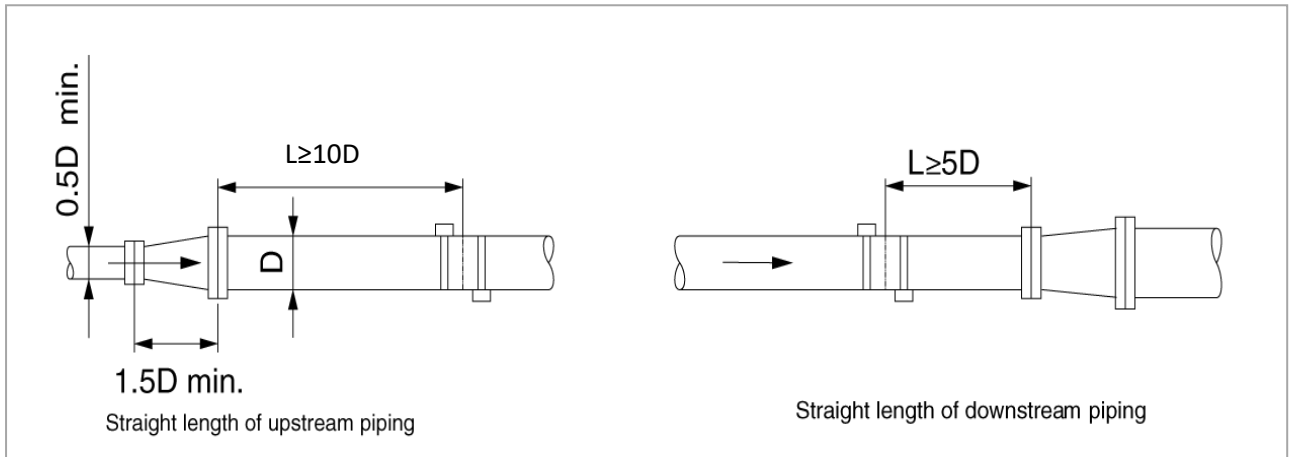

Fig 7: Diffuser pipe

- For Reducer

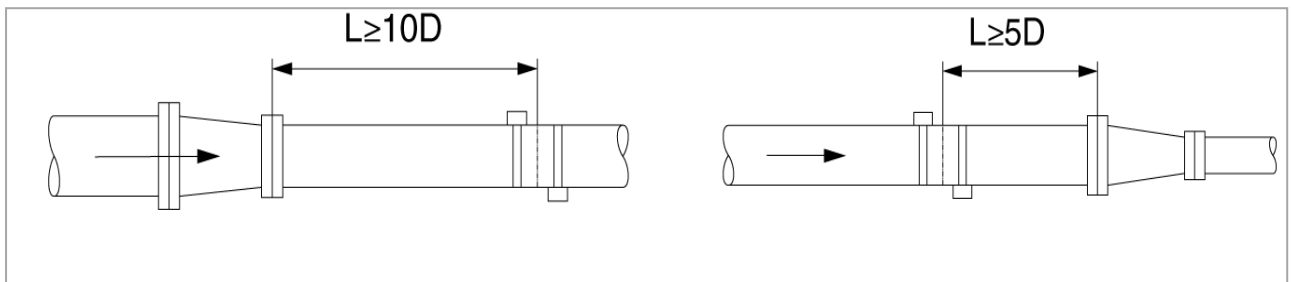

Fig 8: Reducer pipe

- For Valve

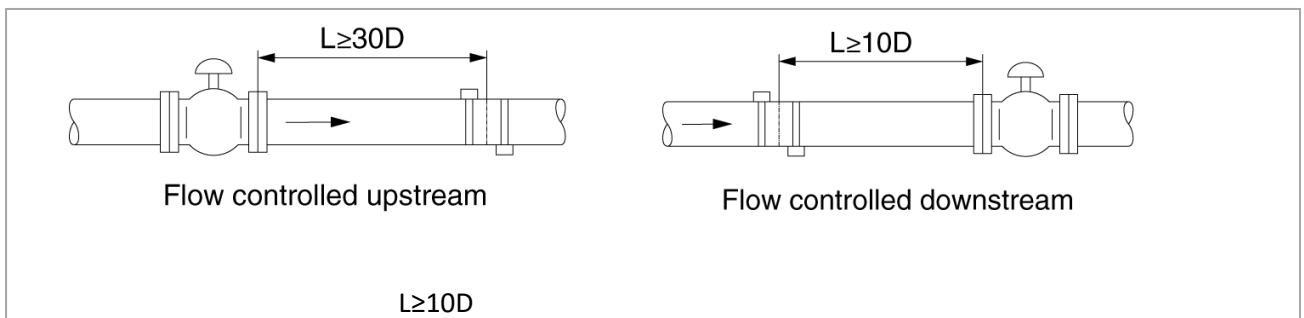

Fig 9: Valve

- **For Pump**

The figure below shows the installation point of transducers when a pump is used in the pipeline.

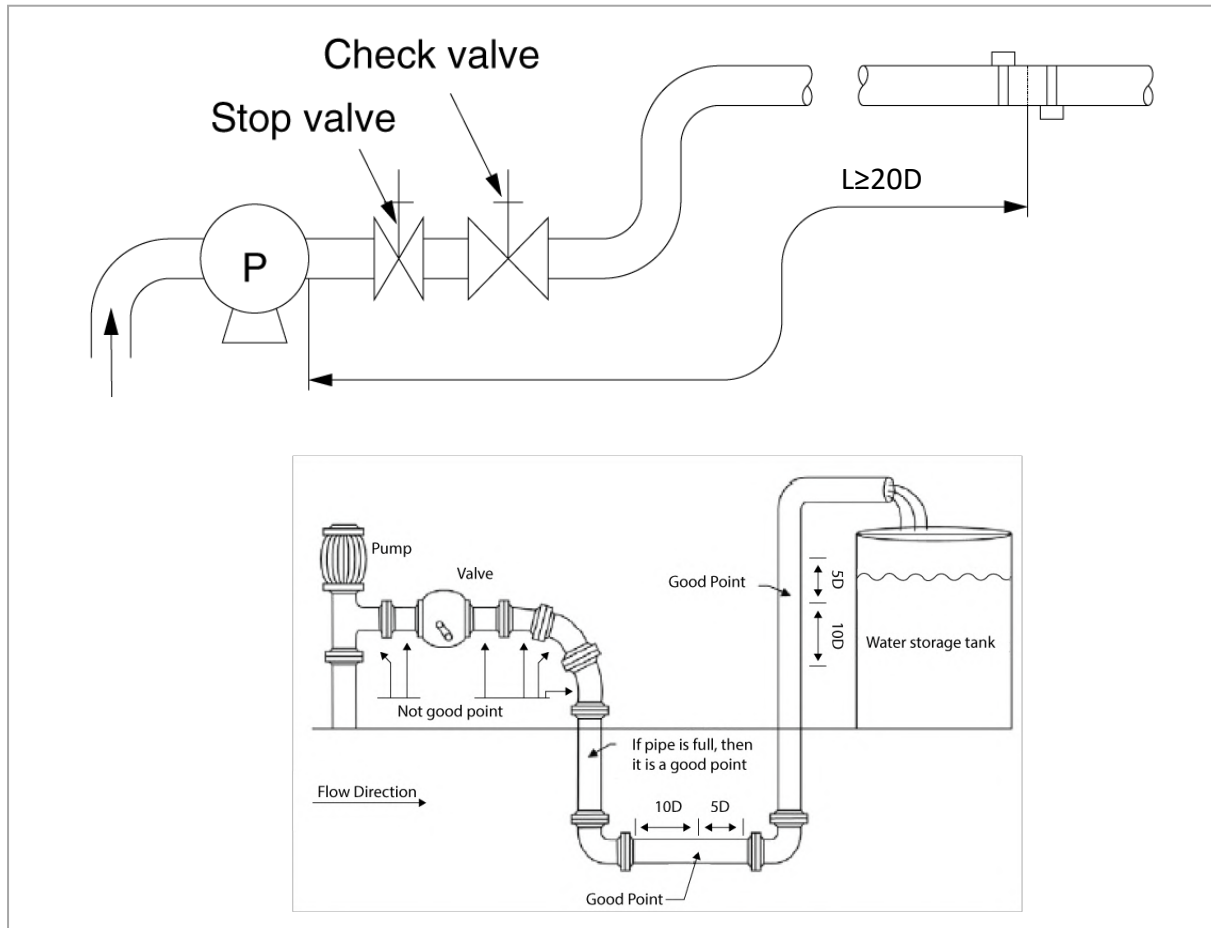

Fig 10: Pump

The above figure shows the installation point of transducers when a compressor is used in the pipeline.

3.3.3 Transducer Installation Method

Before installing, start by cleaning the installation area: remove any rust, paint, and anti-rust layers. Then polish the area using a clean cloth with either alcohol or acetone. Apply a sufficient amount of grease at the installation area and clamp the transducers tightly on the pipe. The grease is used to eliminate any gaps between the transducer and the pipe wall.

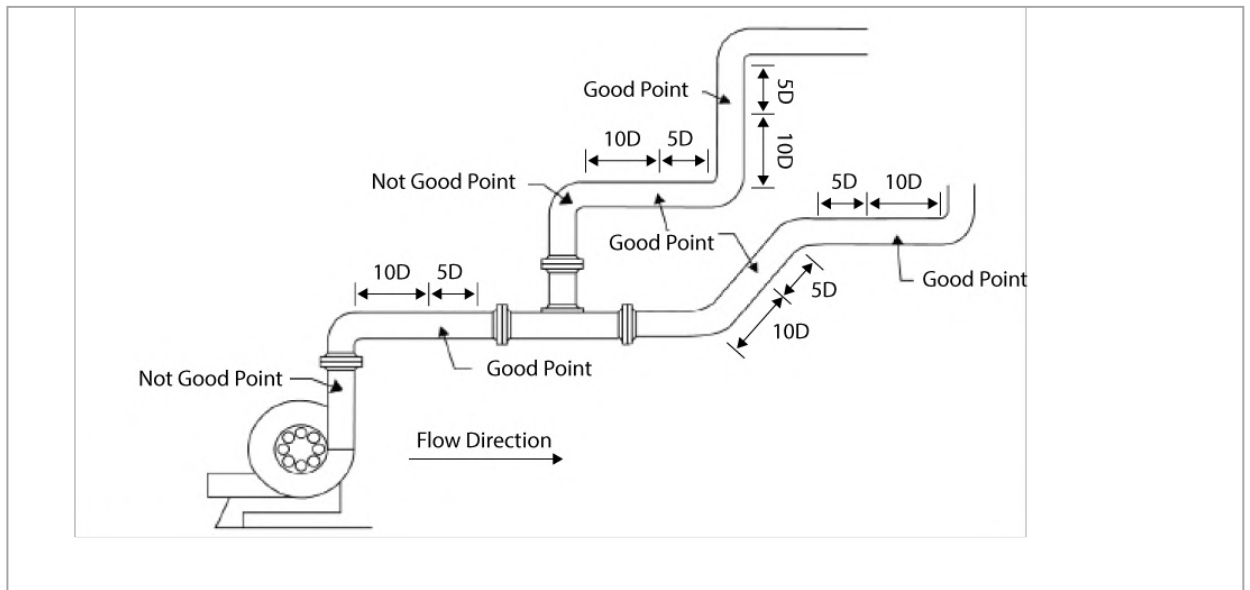

Fig 11: Transducer Installation Method



NOTE

If enough grease is not applied or the transducers are not clamped to the wall tightly, the precision of measurement may be effected.

3.3.3.1 Installation Space

Installation space of the clamp-on type transducer is the inner distance between the two transducers when they are facing each other. After giving the input of the required parameters to the menu of the converter, check the display on the parameter M25 to get the installation space.

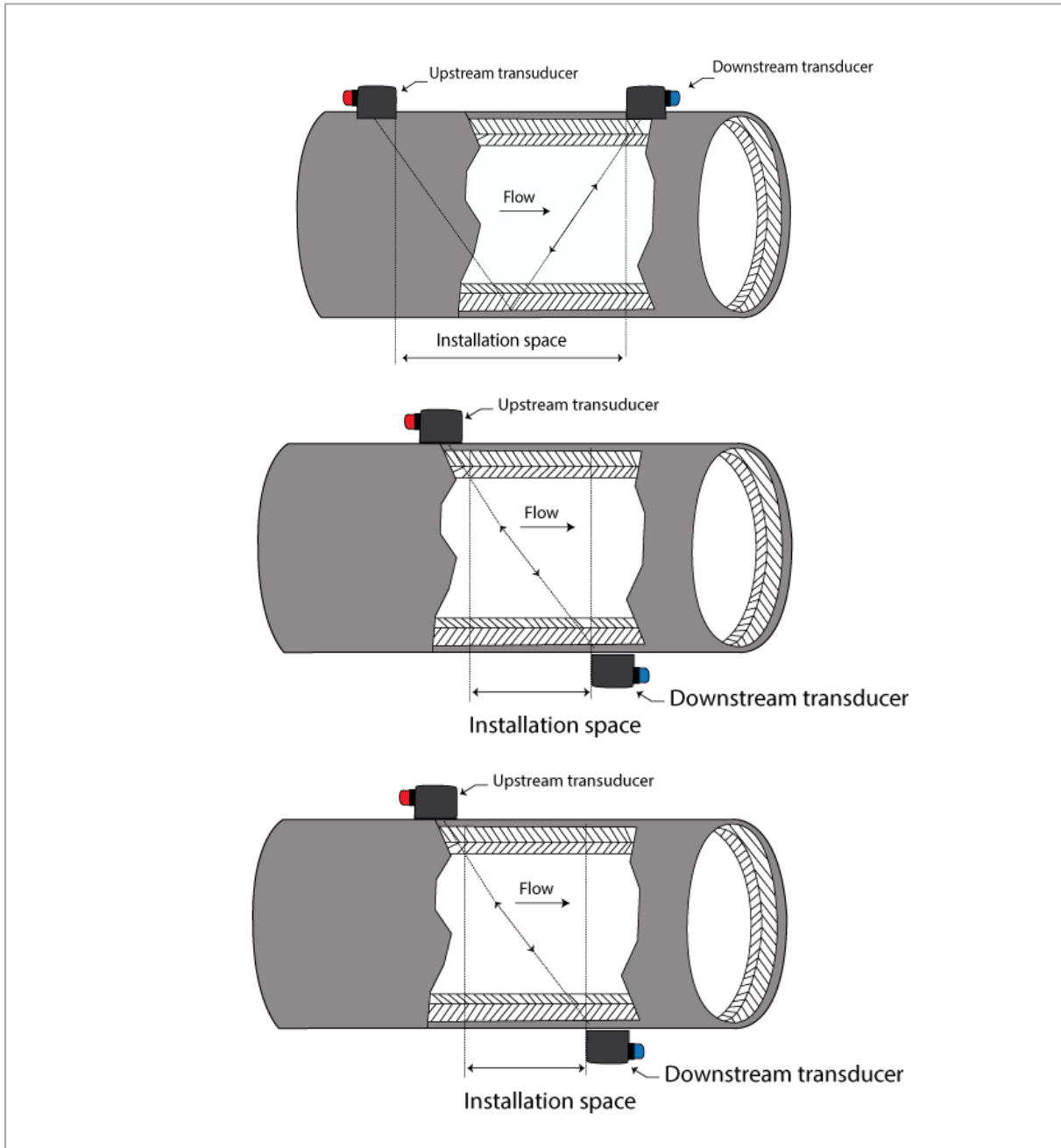

Fig 12: Installation space

3.3.3.2 Installation Method

There are two types of the installation methods i.e. the V method and the Z method.

- **V method**

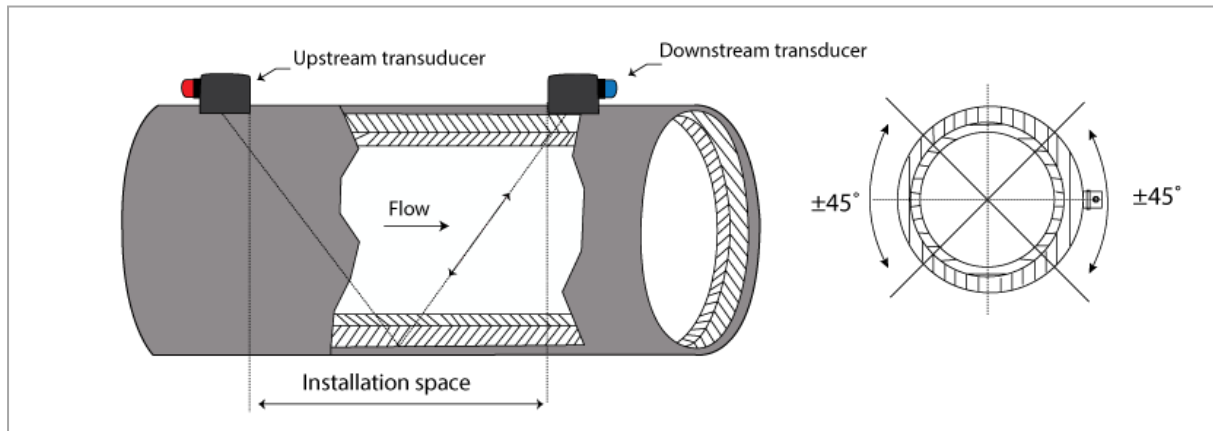

Fig 13: V-Method Installation

V method is a standard installation method and convenient to use for precise measurement of flow. While installing the two transducers, they're horizontally aligned. They are suitable for pipe diameter range $\frac{1}{2}$ " to 16" (DN15mm-DN400mm).

- **Z method**

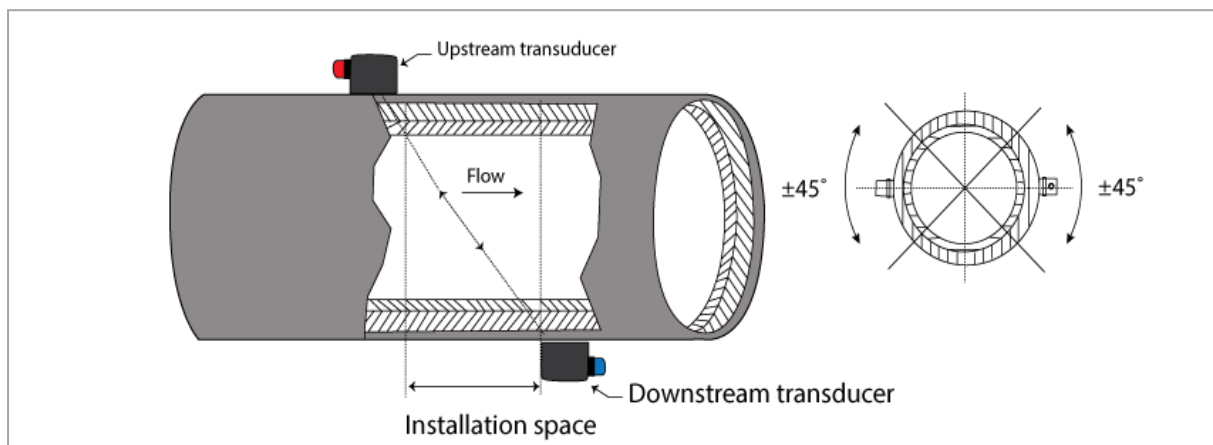

Fig 14: Z-Method Installation

When the pipe diameter is wide, or there are suspended matters in the fluid, or the scaling is too thick and interferes with the normal functioning of the flow meter and weakens the signal in a V method installation, then Z method installation is used. It is also called the single sound path as it can directly transfer the pulse without any reflection required as is required in case of V method and therefore has less signal attenuation.

- **W method**

Normally, this type of mounting used when the material of pipe is plastic and had diameter of 10 millimetre to 100 millimetre. for small pipe size like 1/2" ,W & Z type method is more accurate than V & also convenient for installation as it provides better spacing distance than V method.

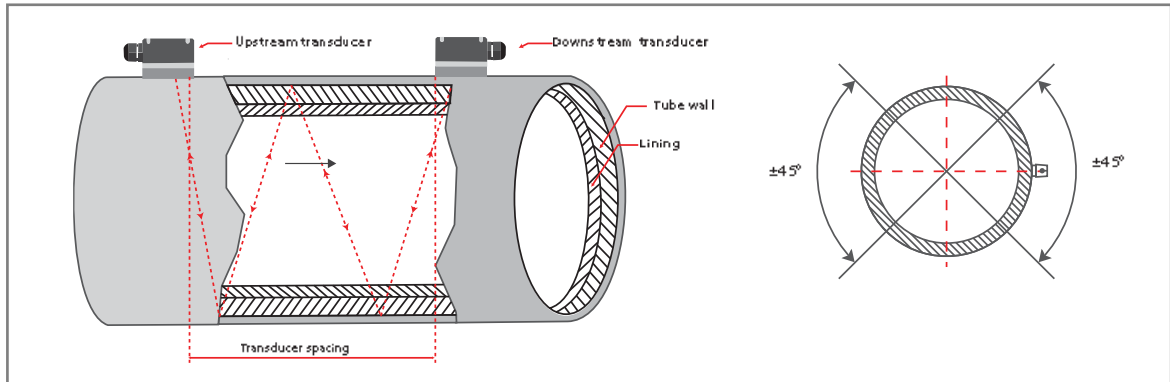

Fig 15: W-Method Installation



Note

When installing the transducers, the pipe area where the transducers are to be installed, must be clean

The shield cable must be properly connected, and proper sealants must be applied to the transducers to prevent the water from entering inside the transducers

Use stainless steel band straps to fix the transducers and to prevent it from moving

Apply enough couplant around the area, so that transducers touch the pipe and prevent air, sands, and rust that interfere with the pulse transfer

3.4 Instrument Well Construction Requirements

To install transducers in an instrument well, there must be enough installation room and should be convenient for people to stand up and work. Distance between the pipe wall and well wall is at least above 22-inch, width is more than $(D+22 \times 2)$ inch, cement pipe width is more than $(D+28 \times 2)$ inch, and the instrument well axial width L is more than $D+48$ inch. When installing transducers, avoid the placement on the flange, welding line, reducing. Do best to install transducers in the range of $\pm 45^\circ$ of the horizontal position of pipe axis.

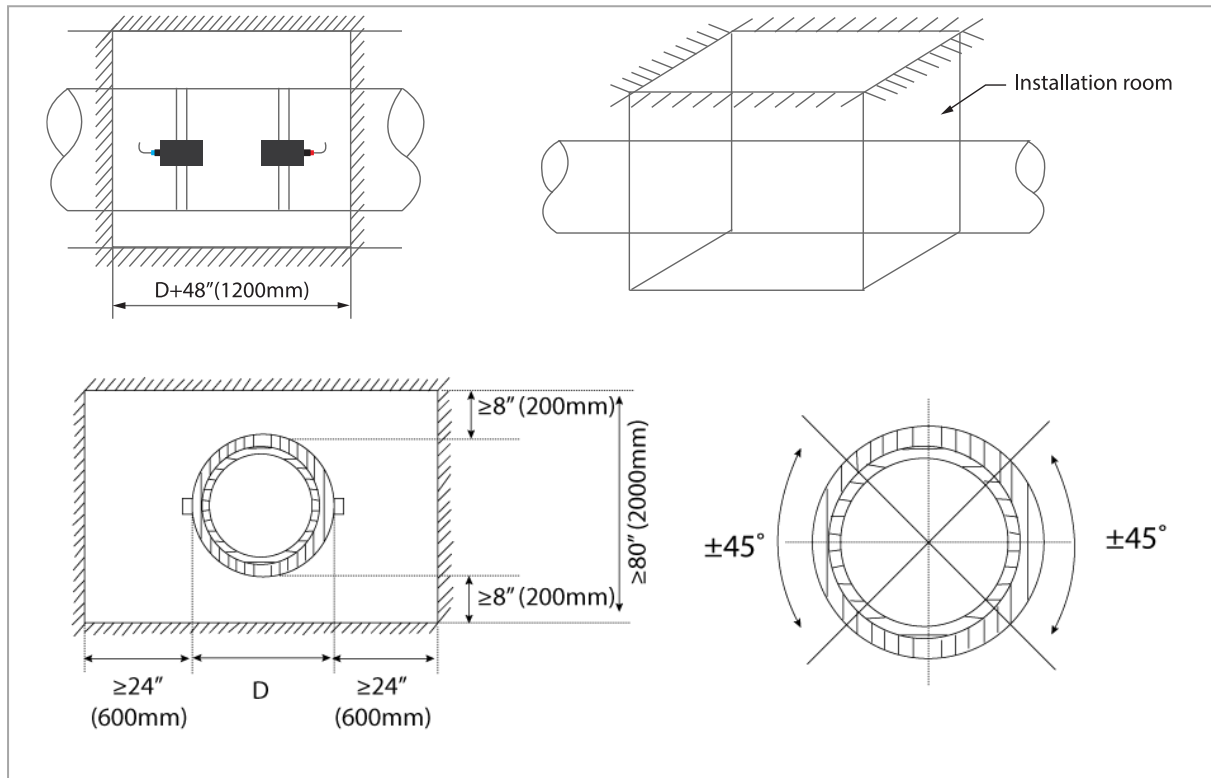

Fig 16: Horizontal position of pipe axis

3.5 Quick Pipe Parameter Setting

The user must set the parameters when measuring the following:

1. Pipe outer diameter
2. Pipe wall thickness
3. Pipe material
4. Liner parameter (if having liner, then the liner thickness and sound velocity)
5. Fluid types
6. Transducer's type
7. Transducer's installation method
8. Solidification parameter

4 Electrical Connections

4.1 Basic Requirement

The flow meter should be connected to the AC or DC power supply.

85VAC to 264VAC	Power Consumption: Less than 1.5W
8VDC to 36VDC	Power Consumption: Less than 1.5W

4.2 Power Supply and Signal Wiring Diagram of 1200A-100F1 Enclosure

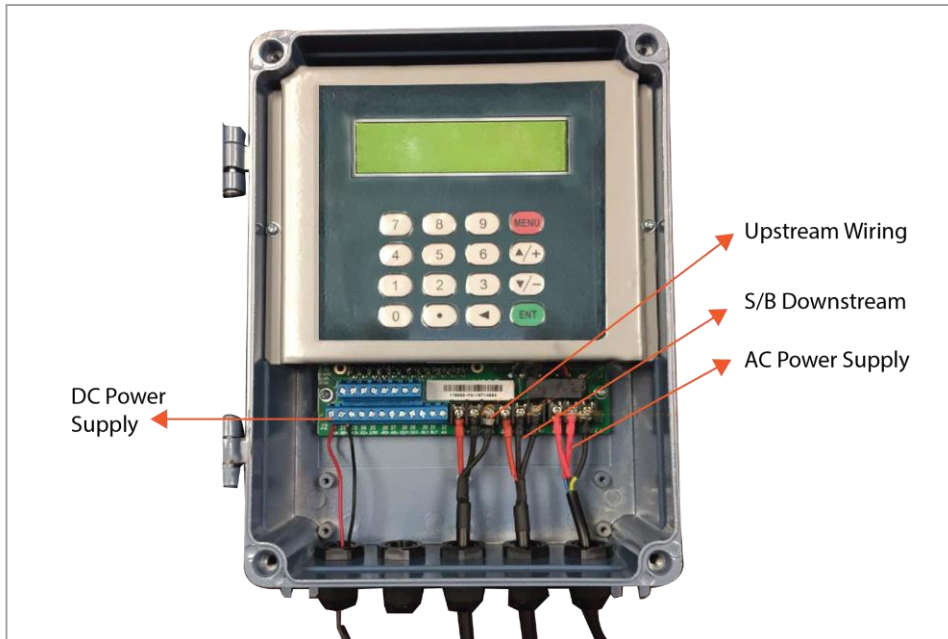

Fig 17: Power Supply and Signal Wiring Diagram

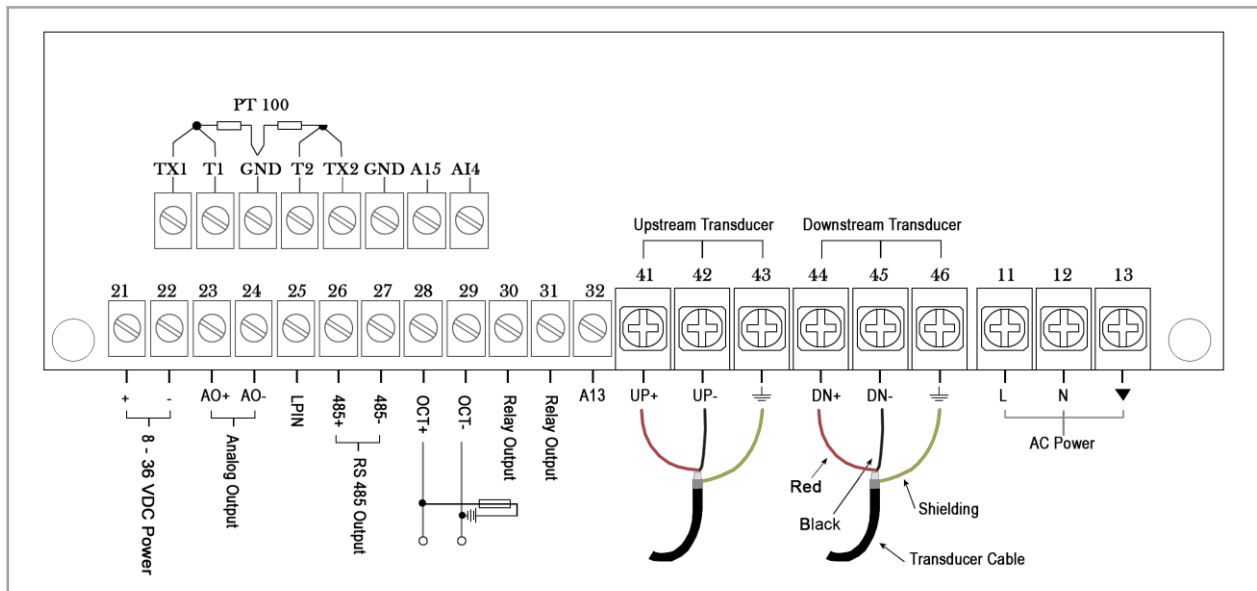

Fig 18: Power Supply and Signal Wiring Diagram

4.2.1 Keypad

- The keypad of the flow meter has 16+2 keys.
- Keys 0 ~ 9 and • are keys to enter numbers.
- Key ▲/+ is the going UP key when the user wants to go to the upper menu window. It also works as '+' key when entering numbers.
- Key ▼/- is the going DOWN key when the user wants to go to the lower menu window. It also works as the '-' key when entering numbers.
- Key ◀ is the backspace key when the user wants go left or wants to backspace the left character that is located to the left of the cursor.

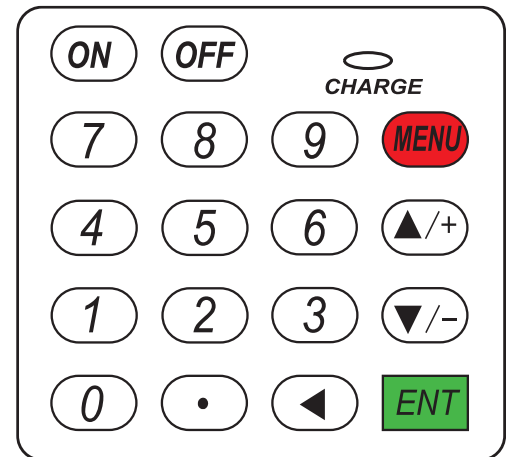

Fig 19: Keypad 1200A-100H

- Key **ENT** is the ENTER key for any input or selections.
- Key **MENU** is the key for the direct menu window jump over. Whenever the user wants to proceed to a certain menu window, the user can press this key followed by a 2-digit number.
- The **MENU** Key is shortened as the 'M' key hereafter when referring to menu windows
- The **ON** key is for the power on.
- The **OFF** key is for the power off.

4.2.2 Menu Windows

The user interface of this flow meter comprises about 100 different menu windows that are numbered by M00, M01, M02 ... M99.

There are two methods to get into certain menu window:

- Direct jump in. The user can press the **MENU** key followed by a 2-digit number. For example, the menu window M11 is for setting up pipe outer diameter. Pressing **MENU 1 1** will display the M11 menu window immediately.
- Press ▲/+ (Up) or ▼/- (down) key. Pressing the ▲/+ key will show to the user the lower-numbered menu window. For example, if the current window is on M12, the display will go to window M11 after the ▲/+ key is pressed once.
- There are three different types of menu windows:
 1. Menu windows for number entering, e.g., M11 for setting up pipe outer diameter.
 2. Menu windows for option selection, e.g., M14 for the selection of pipe materials.
 3. Results display windows, e.g., window M00 for displaying Velocity, Flow Rate, etc.
- For number entering windows, the user can directly press the digit keys if the user wants to modify the value. For example, if the current window is on M11, and the user wants to enter 219.2345 as the pipe outer diameter, then, the flowing keys should be pressed:

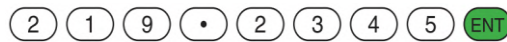

- For option selection windows, the user should first press the **ENT** key to get into option selection mode. Then, use ▲/+ (Up) , ▼/- (down) or digit key to select the right option. Consequently, press the **ENT** to make the selection.
- For example, assume your pipe material is stainless steel and you are currently on menu window M14 which is for the selection of pipe materials (if you are on a different window, you need press (1) (4) **MENU** first in order to enter into the M14 window.)
- You need to press the **ENT** key to get into the option selection mode. Then, either press the ▲/+ (Up) and ▼/-(down) keys to make the cursor on the line that displays “1. **Stainless Steel**”, (1) or press the key directly. At the end, press **ENT** again to make the selection.
- Generally, the **ENT** key must be pressed to get into the option selection mode for option modifications. If the “**Locked M47 Open**” message is indicated on the lowest line of the LCD display, it means that the modification operation is locked out. In such cases, the user should go to **M47** to have the instrument unlocked before any further modification can be made.

4.2.3 Menu Window List

- **M00~M09 windows** are suitable for viewing the instantaneous flow rate, net totalizer value, positive totalizer value, negative totalizer value, instantaneous flow velocity, date time, battery voltage and estimated working hours for the battery.
- **M10~M29 windows** have to be used for entering system parameters, such as pipe outer diameter, pipe wall thickness, liquid type, transducer type / model, transducer installation method, etc. Transducer installation spacing is also displayed on one of the windows.
- **M30~M38 windows** allow the user to enter the flow rate unit and to configure the totalizer. User can use these windows to select flow rate unit, such as cubic meter or litre, as well as to turn on / off each totalizer, or to zero the totalizers.
- **M40~M49 windows** are for setting response time, zeroing / calibrating the system and changing password.
- **M50~M53 windows** are for setting up the built-in logger.
- **M60-M78 windows** are for setting up timekeeper and displaying software version, system serial number ESN and alarms.
- **M82 window** is for viewing the totalizer.

- **M86~M89 windows** are useful to configure some parameters about the signal management, such as automatic control, power selection and receive window width
- **M90~M94 windows** are for displaying diagnostic data. Those data are very useful when doing a more accurate measurement.
- **M97~M99** are not setup windows but commands for window copy output and pipe parameters output.
- **M+0~M+8 windows** offer some additional functions, including a scientific calculator, display of the total working time, and display of the time and the flow rate when the device is turned on and turned off.

Other menu windows such as **M88** have no functions, or functions were cancelled because they are not applied to this version of the software. The major reason why the menu windows are arranged in this way is to make this version compatible with the previous ones. This will make things easier for a user that wants to switch from a previous version to the new one.

4.3 Power Supply and Signal Wiring Diagram of 1200A-100M



Fig 20: Power Supply and Signal Wiring Diagram

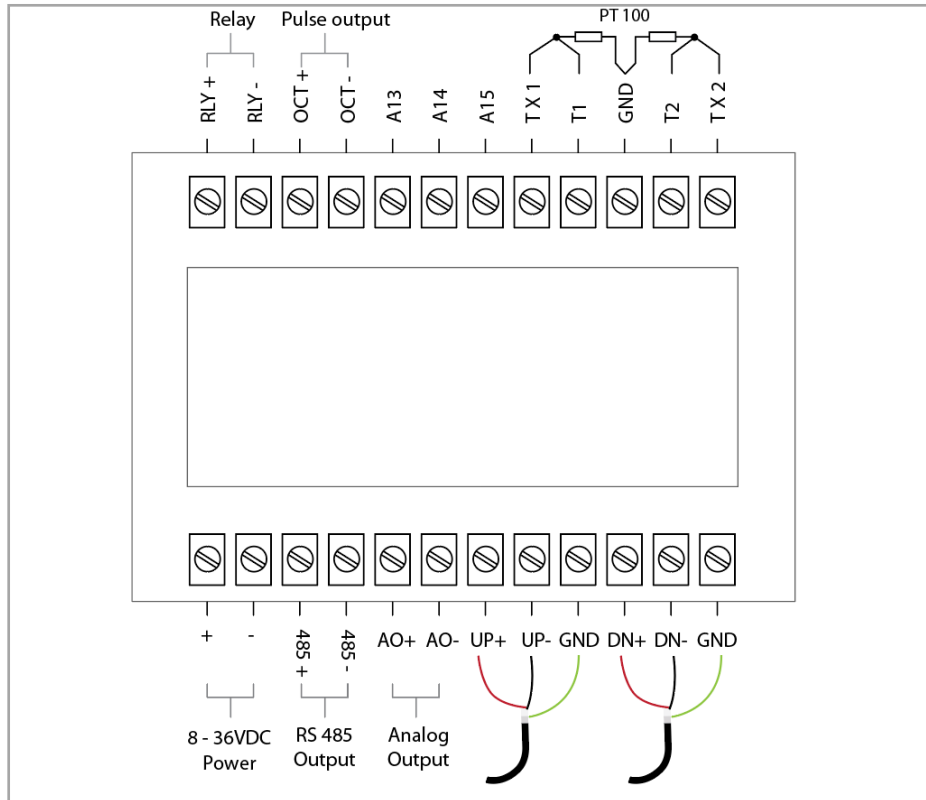

Fig 21: Power Supply and Signal Wiring Diagram

***Note:- Pulse Output:** Passive(Oct+, Oct-), **4-20 mA output:** Active(Ao+,Ao-),
Remarks for Pulse Output: External 24VDC with 100 to 1000 Ohms resistor. 24Vdc supply to resistor to OCT+ Connect PLC/multimeter between OCT- and -Ve of power supply. configure parameters on Meter for OCT output, **Remarks for 4-20 mA output:** Directly Connect PLC to Ao+ & Ao-, **Diagrams for 4-20mA:** Active,

Diagrams for Pulse:

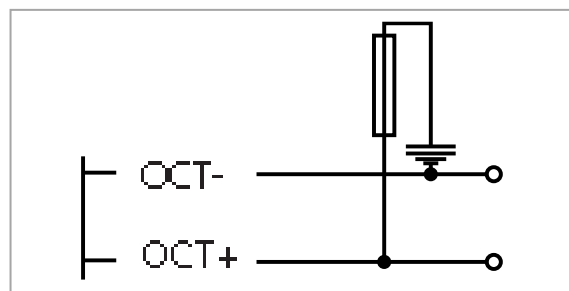

Fig 22: Pulse Diagram

4.4 Power Supply and Signal Wiring Diagram of 1200A-100EXP

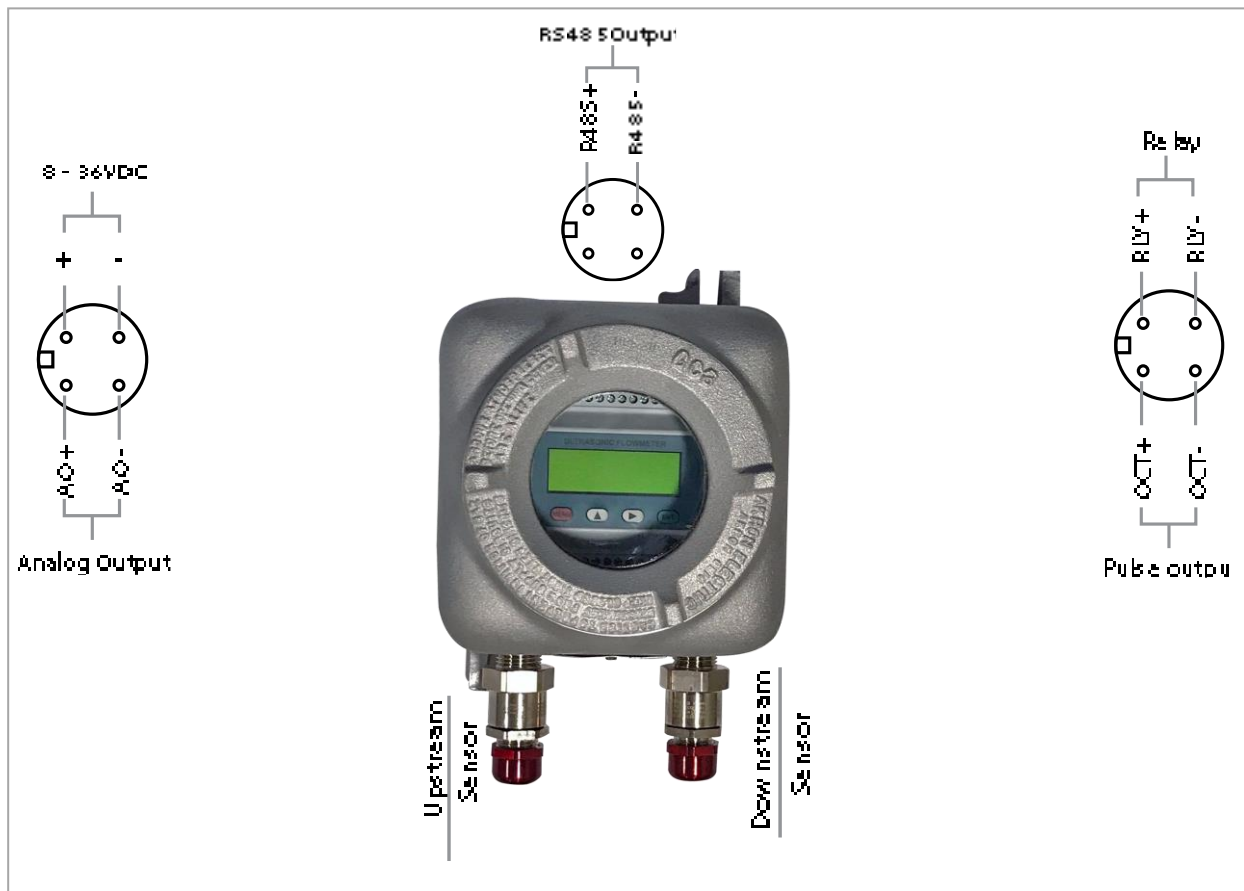

Fig 23: Power Supply and Signal Wiring Diagram



WARNING

- Make sure to connect to ground the power board terminal block

4.5 Transducer Wiring Diagram

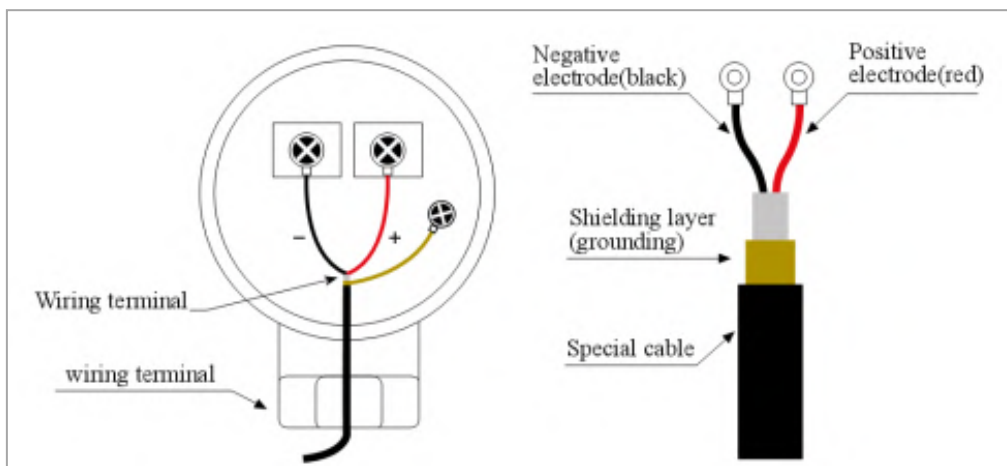

Fig 24: Transducer Wiring Diagram

4.6 Installation Check-Up

After the completion of transducer installation, the user should check the following items to see whether the installation is suitable, whether the received ultrasonic signal is correct and strong enough that it can make the flow meter work normally with long-time running. By checking the receiving signal strength (S), the signal quality (Q) value, the delta time and the transit time ratio (R), the user can determine whether the installation point is good or not. Normally, apply couplant on the transducers and attach them on the pipe, so as to obtain measurement results. But it is better to check the following factors to ensure the flow meter is working properly and the results are reliable and accurate:

4.6.1 Signal Strength (S)

Signal strength S (parameter M90) indicates strength of sending and receiving signals from upstream transducer and downstream transducer by a 3-digit number. [00.0] means there is no signal detected, and [99.9] refers to the maximum signal strength that can be detected. When installing, do your best to adjust the position of transducers and check whether the couplant is sufficient, to make sure to gain the strongest signal. The instrument works well when the signal strength ranges from 60 to 99. When the signal strength is too low, you should check the installation position, installation space, whether the pipe is suitable to install, or you need to change the installation to the Z method. Stronger signal strength should be pursued, because a stronger signal means a stable measurement results, with long and reliable running.

4.6.2 Signal Quality (Q)

Signal quality is indicated as the Q value (display on M90) that verifies whether the receiving signal is good or not. Tek-Clamp 1200A-100F1 transmitter uses 00-99 digits to represent signal quality. 00 represents the worst signal, 99 represents the best signal. Normally the signal quality should be above 60. The reason for poor signal quality could be big interference, or bad installation of transducers, or using bad quality signal cable. To get better signal adjust the transducers repeatedly and check whether the couplant applied is enough or not.

4.6.3 Total Transit Time and Delta Time

The total transit time (or traveling time) and delta time are displayed on the menu window M93. They can display whether the installation is suitable or not. They are the basic two parameters for the flow meter's internal measurement and calculation. When the data of delta time fluctuates too much, the displayed flow rate and velocity will change quickly. If this happens, it means the signal quality is not good; the condition of pipe is not good, unsuitable installation of the transducers, or the wrong parameters were input. Normally the fluctuation of delta time is less than $\pm 20\%$, but when the pipe diameter is too small or there is lower flow velocity, the fluctuation of delta time may be higher.

4.6.4 Transit Time Ratio

Transit-time ratio (parameter M91) is usually used to check whether the transducer installation space is good. If the pipe parameters are correct and the transducers are

installed properly, the transit time ratio should be in the range of $100\pm 3\%$. When the ratio is over the range, you should check,

- If the entered pipe parameters are correct?
- If the actual space of the transducers is the same as or close to what shown on window M25.
- If the transducers are installed properly in the same axis plane of pipe?
- If the mounting location is good, if the pipe has changed shape, or if the pipe is too old (i.e., too much corrosion or liner inside the pipe)?
- If there is any interference source around the flow meter?



NOTE

- Input pipe parameters must be correct, conform to facts, otherwise the flow meter will not work.
- When installing clamp on type transducers, apply enough couplant to make the transducers attach on the pipe, check the signal strength and signal quality displayed on the screen while moving the transducers around installation point to receive the best signal and signal quality.
- To ensure whether the flow meter work normally: check if the signal strength is bigger, signal quality is higher, the displayed flow rate is reliable, and the flow meter work for a long time. If there is a bigger environment electromagnetic interference or lower receiving signal, then the flow rate displayed is poor, and will not be able to work normally for long time.
- After installation, enter M26 to solidify parameters, power on again, check if the results are correct or not.

5 Operation

The Tek-Clamp 1200A-100F1 Ultrasonic Flow meter can use the 16 keys keyboard monitor, the 16 keys parallel and serial port keyboard which includes: 10-digit keys, 2 up/down arrow keys, 1 menu key (M), 1 enter key, 1 decimal point key and 1 backspace key. The keyboard allows users to program quickly and easily.

Here are some usages of 16 keys keyboard:

- '0-9' and '.' are used to input numerical value and menu number.
- '◀' key is used to left backspace or delete left character.
- '<▲/+' and '<▼/- >' are used to shift to upper and lower menu. When inputting digits, these are equal to the "plus" or "minus" keys.
- The 'Menu' key brings up the main menu.
- The '<ENT>' key is mainly used to ensure the input digit and chosen content. The other function is to press it to enter "modify" status before setting parameters.

5.1 Menu Window Details

	Menu Window No.	Function
Flow rate/flow totalizer display	M00	Display instant flow rate/net totalizer. Adjust the units in M30-M32
	M01	Display instant flow rate/instant flow velocity. Adjust the units in M30-M32
	M02	Display instant flow rate/positive totalizer. Adjust the units in M30-M32
	M03	Display instant flow rate/negative totalizer. Adjust the units in M30-M32
	M04	Display instant flow rate/date time
	M05	Display heat flow rate/total heat quantity. Adjust the units in M84, M88
	M06	Display temperature input T1, T2
	M07	Display present battery voltage
	M07	Display analogue input AI3, AI4
	M08	Display system error code
Initial setup	M09	Display today net totalizer
	M10	Input outside perimeter of pipe
	M11	Input pipe outer diameter, data range:0-18000mm
	M12	Input pipe wall thickness
	M13	Input pipe inner diameter
	M14	Choose the kinds of pipe materials
	M15	Input sound velocity of pipe material
	M16	Choose kinds of liner
	M17	Input the sound velocity of liner
	M18	Input the thickness of liner
	M19	Input inner pipe wall absolute degree of roughness
	M20	Choose kinds of fluids
	M21	Input fluid velocity
	M22	Input fluid viscosity
	M23	Choose the types of transducers, including more than 20 types to use
	M24	Choose transducer installation method
	M25	Display transducer installation space
	M26	Parameter solidifying and setup
	M27	Store and read installation parameters on installation point
	M28	When signal set is turning poor, the transmitter keeps the last data. Choosing 'yes' means when the signal is turning poor, the flow meter will display last correct measured data
	M29	Input signal strength when the pipe flow is set to be empty.

		For example: inputting 65 means when the signal strength is lower than 65, the flow meter will think that there is no liquid in the pipe and display the flow value as zero
Flow unit setup	M30	Choose metric or imperial unit
	M31	Choose instant flow rate unit
	M32	Choose totalizer unit
	M33	Choosing the totalizer multiplying factor which function is to multiply totalizer data rang, normally set it as x1
	M34	Net totalizer switch
	M35	Positive totalizer switch
	M36	Negative totalizer switch
	M37	Restore parameters setup before leaving factory and reset totalizer
	M38	Manual totalizer (the key to control on/off)
	M39	Choose operating language, including 8 kinds of different languages for international users to use
	M3•	Setup the LCD display method, inputting 0 or 1 means regular displaying content inputting, 2-39 means automatically cycle displaying method, displaying the previous menu of 2-39, time interval is 8 seconds. When there is no input operation, it will automatically enter cycle displaying status.
Choosing Setup	M40	Damper coefficient
	M41	Input low flow velocity cut-off value
	M42	Setup static zero point
	M43	Clear the zero-point value and restore the solidified zero-point value.
	M44	Set up zero-point deviant by hand
	M45	Flow meter coefficient, rectification coefficient
	M46	Input Network address identification number (IDN)
	M47	Password protecting operation, after the flow meter is setup with password, only browse menus without any modification.
	M48	Input degree of linearity broken line rectification data.at most there is 12 segments broken line, used for users to rectify meter nonlinear.
	M49	Network communication tester, on this window to visit the data transferred from upper computer to judge the problems arise during communication.
Scheduled time output	M50	Optional setup of data output at scheduled time, choose output content at scheduled time to print, more than 20 to select
	M51	Setup output time at scheduled time
	M52	Printing data flow direction control.by default printing data will flow directly to the thermal printer hanged inside bus. Setup printing data output to outside serial port (RS485 port)
AI5 setup	M53	Display analogue input AI5(reserved for the Tek-Clamp 1200A)

		mainboard)	
Input and output setup	M54	Setup of OCT totalizer pulse output, pulse width, range:6 Ms-1000Ms.	
	M55	Choose current loop mode	
	M56	Corresponding data to output of current loop 4mA or 0mA	
	M57	Corresponding data to output of current loop 20mA	
	M58	Verification of current loop output applied to check whether current loop is normal or not.	
	M59	Present output of current loop	
	M60	Date time and setup of the date time of the new is realized by CPU, when upgrading software, time will be slow. So after upgrading, recommended to adjust the date and time to display correctly	
	M61	Software version information and Electronic Serial Number (ESN)	
	M62	Setup serial port parameter	
	M63	Communication protocol choosing (including compatible protocol choosing), two options, choosing MODBUS-RTU means using binary system MODUS-RTU protocol. Choosing MODBUS-ASCII+previous protocol means using ASCII protocol, at this time can support several protocols simultaneously, including MOSBUS-ASCII, previous 7 version protocol, FUJI protocol, Meter-BUSx protocol etc.	
	M64	Analogue input AI3	By inputting the measuring range, the flow meter will turn current signal into data range users need
	M65	Analogue input AI4	
	M66	Analogue input AI5	
	M67	Setup frequency range of frequency output signal. Frequency signal output represents instant flow rate value by signal frequency value. Default: 0-1000Hz, Max-range:0-999Hz. Output frequency signal by special frequency output unit.	
Input and output setup	M68	Setup lower limit flow of frequency signal output	
	M69	Setup upper limit flow of frequency signal output	
	M70	LCD backlit control	
	M71	LCD contrast ratio control	
	M72	Work timer, logging work time of the flow meter by unit of second.it can reset.	
	M73	Setup lower limit flow of frequency signal output	By adjusting the lower and upper limit of alarm, confirm a range. When actual flow is over the range set in this
	M74	Setup upper limit flow of frequency signal output	

	M75	LCD backlit control	window, then it creates an alarm signal output that is transferred to outside by setup OCT or relay.
	M76	LCD contrast ratio control	
	M77	Beeper setup options	
	M78	Setup Open Collector Transistor output(OCT) output options	
	M79	Setup relay(OCT2) output options	
	M80	Choose input signal of batch controller	
	M81	Batch controller	
Heat quantity measuring	M82	Day/month/year totalizer, check the flow rate and heat quantity of the totalizers	
	M83	◦ Automatically replenish flow switch during the period of power off, default status: off this function is not available under special conditions.	
	M84	Choosing heat quantity unit, 1. GJ(default) 2. KCal 3. KW 4. BTU (imperial unit)	
	M85	Choose temperature signal origin, if choosing inputting temperature signal by AI3, AI4, then need temperature transmitter that can output 4-20mA current signal.	
	M86	Heat capacity, default: GB-CJ128 enthalpy potential method. Temperature difference method is available also.	
	M87	Heat quantity totalizer switch	
	M88	Heat quantity multiplier factor.	
	M89	Display present temperature difference and setup temperature difference sensitivity.	
	M8•	Options of installation of heat meter on supply water pipe or return water pipe	
Diagnosis	M90	Display the signal strength and signal quality	
	M91	Display the transit time ratio	
	M92	Display the calculated fluid sound velocity.	
	M93	Display the total transit time and the delta time	
	M94	Display the Reynolds number and the pipe coefficient	
	M95	Display positive, negative heat quantity totalizer, start cycle display function.	
Added menu windows	+0	Display the time of power on/off and flow rate	
	+1	Display the total working time of the flow meter	
	+2	Display the last time of power off.	
	+3	Display the flow rate of last power off	
	+4	Display total times of power on	
	+5	Scientific calculator	
	+6	Setup threshold value of fluid sound velocity	

	+7	Net totalizer of this month
	+8	Net totalizer of this year
	+9	Operating time with trouble (including power off time)
Hardware adjustment menu windows	.2	store static zero point
	.5	setup threshold value of Q value
	.8	max instant flow rate of this day and this month
	.9	serial port testing window with CMM direct output
	-0	circuitry hardware parameter adjusting entrance (only inputting password to enter following windows)
	-1	4-20mA current loop calibration
	-2	A13 inputting calibration of analogue input 4 mA
	-3	A13 inputting calibration of analogue input 20mA
	-4	A14 inputting calibration of analogue input 4mA
	-5	A14 inputting calibration of analogue input 20mA
	-6	A15 inputting calibration of analogue input 4mA
	-7	A15 inputting calibration of analogue input 20mA
	-8	Zero-point setup of PT100 at lower temperature(
	-9	PT100 setup zero point at higher temperature (>55°C)
	-A	PT100 standard calibration at 50°C
	-B	PT100 standard calibration at 84.5°C

i NOTE

- Violet colour indicates new added or changed functions
- Blue colour means the menus related with heat quantity measurement

5.2 Work parameter solidification of the Flow meter and option indication

The new Tek-Clamp 1200A has 3 work parameter areas respectively. They are: **Present parameter data block, Solidification parameter data block, and the User pipe parameter data block.**

- Present parameter data block is built-in internal RAM. If outside power supply and spare battery are shut-off together, then the present work parameter is lost.
- Solidification parameter data block is built-in internal FLASH. Normally it will not lose the data. For stable work application, use the solidification parameter of M26 to solidify the parameter data block in RAM to FLASH and setup recalling the work parameter. FLASH presents the parameter of data block when the flow meter is powered on each time.
- User parameter data block can store 9 sets of commonly used pipe parameters. The access operation is in M27.

5.3 Zero-Point Setup and Zero-Point Solidification

The new transducers have a “zero point”, it means that when fluid flow velocity is zero, the flow meter will display a non-zero flow value. This value will repeatedly add to the indicating value of the flow meter under any flow velocity, for example, assume that the zero-point velocity is 1gpm, present flow velocity is 10gpm, then the

indicating value of the flow meter is 11gpm. So, the newly installed or changed transducers normally need to adjust zero-point and log zero-point value.

To adjust zero-point, you've to go in menu M42. The zero-point value after adjusting is only stored in RAM parameter area temporarily and is not solidified in FLASH. If the spare battery is off or choosing the solidification parameters in FLASH as work parameters when the flow meter is powered on, then the zero-point will lose the stored value. In order to keep the zero-point value forever, users must use M.2 to store the zero-point after adjusting zero-point for each time.

5.4 Factory Use of the Scaling Factor Solidification

Same as the principle of storing zero-point value, the scaling factor needs to be solidified after calibration before leaving the factory. The scaling factor can be edited in M.1. Use two grade passwords to visit.

5.5 Analog Calculating Function Application

When the setup pipe diameter is zero, the instant flow velocity is 1.2345678ft/s, instant flow rate is equal to zero, and "R" status is displayed. Inputting a set value in M44 can obtain changeable totalizer output and using this function, flow meters can be tested, and network software can be adjusted without connecting the transducers.

5.6 Analogue Input Interface as Digital Input Interface: Method and Introduction

The new Tek-Clamp 1200A series' analogue input interface can work as a digital input interface but note that the loop input current should not be over 20 mA. When outer digital quantity voltage is 5V, you should series connect a 1k resistor in return circuit. If the digital quantity voltage is 12V, then series connect a 2k resistor.

5.7 Introduction of Serial Peripheral Extension Interface

Serial peripheral extension interface is like USB interface. It has input, output, power supply+, power supply-; a total of 4 lines for each measuring. It can also give output of instant flow, instant heat flow, positive total, 4-20mA value, frequency value and printing data etc. Different function models can take down data according to the requirements. The serial bus use 4800 Baud Rate.

5.8 Realize Medium Identifying Function

For example: application in mixture of oil and water, to judge if the medium in pipe is water or oil. You can input lower limit of water flow in M+6, i.e. 1400ft/s for this example. When the fluid flow velocity measured by the flow meter is lower than 1400ft/s, an internal signal is created, which is used to indicate that the fluid is another medium. This signal can be given as the output by OCT or read by MODBUS protocol.

5.9 Restoring the Flow meter to Factory Default

To clear all set parameters and to restore to the original factory default, use only the serial port or parallel port keyboard to enter M37 and click <•><◀>, so that it can restore default set parameters before leaving the factory.



NOTE

This function is only used during the first installation.

6 Totalizer reset

Totalizer reset: press Menu-37-ENT= take you to totalizer reset menu.

by Up & down key select "YES" press ENT. select the type for totalizer want to reset ex: Pos., NEG or Select ALL. press ENT totalizer Reset complete. press Menu-0-ENT that direct you to main screen.

7 BTU settings

Settings to be done on Tek Clamp on 1200A as below:

M84	Choose heat quantity unit (GJ,Kcal,KW,BTU(Imperial))
M85	Choose temperature signal origin, if choosing inputting temperature signal by AI3, AI4, then need temperature transmitter that can output 4-20mA current signal.
M86	Heat capacity, default: GB-CJ128 enthalpy potential method. Temperature difference method is available also.
M88	Heat quantity multiplier factor.
M8•	Options of installation of heat meter on supply water pipe or return water pipe
M05	Display heat flow rate/total heat quantity. Adjust the units in M84, M88
M06	Display temperature input T1, T2
M26	Solidify settings. i.e save the changes

8 Maintenance

This section covers maintenance techniques and guidelines.

8.1 Maintenance Service

For operational problems, please contact the technical support department by telephone, fax, email or internet. In most cases, problems should be solved immediately. For any hardware failure of the instrument, we recommend our customers to send back the instrument for service. Please contact the technical support department with the model number and serial number of the unit before sending the unit back to us. Both numbers can be found on the product label. For each service or calibration request, we will issue a Return Materials Authorization (RMA) number. Take note that the cost for repairing can only be determined after receipt and inspection of the instrument. A quotation will be sent to the customer before proceeding with the service. Normally, the buyer is responsible for the transportation of meters and freight.

8.2 Software Upgrade Service

We provide free-of-charge software upgrade services. Please contact the factory for any recently developed software.

8.3 Important Notice for Product Return

Before returning the instrument for warranty repair or service, please read the following carefully:

- If the return item has been exposed to nuclear or other radioactive environment, or has been in contact with hazardous material that could pose any danger to our personnel, the unit cannot be serviced
- If the return item has been exposed to or in contact with dangerous materials, but has been certified as hazard-free device by a recognized organization, you are required to supply the certification for the service
- If the return item does not have a RMA# associated, it will be sent back without any service conducted

9 Troubleshooting

This section provides troubleshooting techniques for most common operating problems.

The Tek-Clamp 1200A shows an error on the corner of the menu window via an identification code in a timely order. All the existing errors are displayed on the parameter M08. Self-diagnosis on hardware is conducted every time the flow meter is powered on. Some errors can even be detected during normal operation. For the errors that are undetectable due to incorrect settings or improper testing conditions, the flow meter will display useful information to help the user to quickly debug the error and solve the problems according to the methods listed in the tables below:

Errors displayed of Tek-Clamp 1200A are of two kinds:

- 1) circuit hardware errors (refer to table 1).
- 2) Measurement errors (refer to table 2).

Table 1. Hardware self-diagnosis errors and solutions

LCD display information	Causes	Solution
ROM Verification Error	ROM operation illegal / error	Contact the manufacturer
Logger Reading Error	Stored parameters are wrong	Power on again/contact the manufacturer
System Logger Error	System stored data area has error	Power on again/contact the manufacturer
Measuring Circuit Hardware Error	Sub-CPU circuit errors	Power on again/contact the manufacturer
CPU Clock Speed Error	System timer has errors	Power on again/contact the manufacturer

Date Time Error	System date and time are wrong	Reset date and time
No Display. Erratic or Abnormal Operation	Problem with wiring	Check wiring connections. No influence of measuring normally
No Response to Key Pressing	<ul style="list-style-type: none"> Keypad is locked Bad plug connection 	Input password to unlock keyboard, or check wiring connections, no influence of measuring normally

Table 2. Working status errors code causes and solutions

Code	M08 displaying	Causes	Solutions
*R	System works normally	Normal system	-
*J	Circuit Hardware Error	Hardware problem	Contact the manufacturer
*I	No Signal	<ul style="list-style-type: none"> Unable to receive signal Loose contact or not enough couplant between transducer and pipe surface Transducers installed improperly Scaling on inner pipe wall is too thick New changed liner 	<ul style="list-style-type: none"> Make sure the transducer is in tight contact with pipe surface, and the couplant is enough Polish the pipe surface and clean the pipe surface. Clear paint, rust Check original installation parameter settings Clear the scaling or change the pipe with thick scaling, normally change to another measurement point that has little scaling, the meter can work normally Wait until the liner has been solidified and then test
*H	Lower signal strength received	<ul style="list-style-type: none"> lower signal causes are the same with code "I" 	Solutions are the same with code "I"
*H	Poor signal quality received	Poor signal quality which includes above all causes	Includes above all solutions
*E	The current of Current Loop is over 20mA (won't influence the	<ul style="list-style-type: none"> 4-20mA current loop output overflow 100% 	Check current loop settings on M56. Or confirm if the actual flow rate is too high

	measurement, if current output is not being used)	<ul style="list-style-type: none"> Improper settings for current loop output 	
*Q	Frequency Output is over the set value (won't influence the measurement, if frequency output is not being used)	<ul style="list-style-type: none"> 4-20mA current loop output overflow 120% Improper settings for current loop output 	Check frequency output settings (refer to M66-M69). or Confirm if the actual flow rate is too high
*F	Listed in table 1	<ul style="list-style-type: none"> Find problems when powered on and during self-diagnosis Permanent hardware errors 	<ul style="list-style-type: none"> Power on again, check the information showed on screen, handled according to table 1, if not solved, contact manufacturer Contact manufacturer
*G	Adjusting Gain >S1 Adjusting Gain >S2 Adjusting Gain >S3 Adjusting Gain >S4 (displayed on M00, M01, M02, M03)	Instrument is in the progress of adjusting the gain to prepare the measurement. If stopped at S1 or S2 or switched between S1 and S2, this means the signal is too low to receive or not a good signal at all	-
*K	Empty the pipe, setup in M29	no liquid in the pipe or wrong setup.	If there is liquid, input 0 value in M29

9.1 Error Messages After Switching On

Error Message	Reason	Countermeasure
ROM Testing Error	Software problem	(1) Restart the device
Segment Test Error		(2) Contact Tek-Trol LLC
Stored Data Error	The parameters entered by the user are not integrated	Press the ENTER key. All values are reset to default.
Date Time Error	Number error in the calendar	Initialise the calendar via window M61
Repeated reboot	Hardware problem	Contact Tek-Trol LLC

9.2 Further Errors and Countermeasures

- When the device indicates 0.0000 even though there is a volume flow and an "R" glows in the display and the signal quality Q is ok, there must be a different error. In many cases, this means that the zero point has been set incorrectly. Go to menu M432 and reset the zero point.

2. The displayed volume flow is obviously too low or too high:
 - a) Probably, the volume flow in window M44 has been entered manually. Set this value to "0".
 - b) Problems with the sensor installation
 - c) Possibly, the display was set to "0" via M42 despite an existing volume flow. Repeat the zero-point setting and make sure that there is no flow in the pipe.
3. The real battery life is shorter than the value stated in M07.
 - a) The battery has exceeded its life cycle.
 - b) The battery has not been charged completely or the charging procedure has been interrupted too frequently. Charge the battery again. If the problem persists, contact Tek-Trol LLC.
 - c) When the battery voltage is between 3.70 and 3.90 V, discrepancies between the estimated and the actual transit time can occur.

9.3 Further Errors and Countermeasures

Error codes are indicated by a single letter in the lower right corner of the display. However, these only occur in the menus M00, M01, M02, M03, M90 and M08. The following chart shows the error codes and countermeasures.

Error code	Message in window M08	Reason	Countermeasure
R	System Normal	No error	-----
I	Detect No Signal	(1) No signal (2) Sensors installed improperly (3) Too much fouling (4) Liner too thick (5) Sensor cable not properly connected	(1) Change measuring location (2) Clean measuring location (3) Check the cables
J	Hardware Error	Hardware problem	Contact Tek-Trol LLC
H	Poor Signal Detected	(1) Poor signal (2) Sensors installed improperly (3) Too much fouling or contamination (4) Liner too thick (5) Sensor cable not properly connected	(1) Change measuring location (2) Clean measuring location (3) Check the cables (4) Check the contact gel
Q	Frequency Output Over	The output frequency is outside the permitted range	Check the values in the windows M67, M68 and M69. Enter higher values in window M69
F	System RAM Error Date Time Error CPU or IRQ Error ROM Parity Error	(1) Temporary Problems with the RAM or RTC (2) Permanent Problems with the hardware	(1) Restart the device (2) Contact Tek-Trol LLC
1 2 3	Adjusting Gain	The device is currently re-setting the signal gain; the number	-----

		indicates the current work progress	
K	Empty pipe	(1) No liquid in the pipeline (2) Setting error in menu M29	(1) Choose a pipe that contains liquid (2) Enter "0" in window M29.



NOTE

- The codes *Q, and *E displayed do not affect measurement. They only mean current loop and frequency output have problems

10 Appendix

10.1 Tables: Pipe Size

10.1.1 Copper - Standard Pipe Size Charts:

Classification: The copper tube is classified into four distinct specifications based on the wall thickness for a specific outside diameter. The tables given underneath are reference dimensions dependent on application:

Size / Nom. Dia. (Outside)	Nom. Wall Thickness	Max. Working Pressures*			Usage: General engineering, heating, gas reticulation, sanitary plumbing, underground works, and heavy-duty requirements including hot and cold-water supply
		Half Hard	Hard	Annealed	
inch(mm)	inch(mm)	bar+ (psi)	bar+ (psi)	bar+ (psi)	
¼" (6)	1/32" (0.8)	188 (2726)	223 (3234)	144 (2088)	
5/16" (8)	1/32" (0.8)	136 (1972)	161 (2335)	105 (1522)	
3/8" (10)	1/32" (0.8)	106 (1537)	126 (1827)	82 (1189)	
7/16" (12)	1/32" (0.8)	87 (1261)	104 (1508)	67 (971)	
½" (15)	1/32" (1.0)	87 (1261)	104 (1508)	67 (971)	
11/16" (18)	1/32" (1.0)	72 (1044)	85 (1232)	55 (797)	
7/8" (22)	1/32" (1.2)	69 (1000)	84 (1218)	53 (768)	
1 1/8" (28)	1/32" (1.2)	55 (797)	65 (942)	42 (609)	
1 3/8" (35)	1/16" (1.5)	54 (783)	65 (942)	41 (594)	
1 11/16" (42)	1/16" (1.5)	45 (652)	54 (783)	34 (493)	
2 1/8" (54)	1/16" (2.0)	47 (681)	56 (812)	36 (522)	
2 5/8" (66.7)	1/16" (2.0)	37 (536)	45 (652)	28 (406)	
3 1/32" (76.1)	1/16" (2.0)	33 (478)	39 (565)	25 (362)	
4 5/16" (108)	1/16" (2.5)	29 (420)	34 (493)	22 (319)	

*Based on designated temp. at 149°F

Size / Nom. Dia. (Outside)	Nom. Wall Thickness	Max. Working Pressures*			Usage: General purpose applications, sanitation, central heating, and above-ground services including drinking water supply, hot and cold-water systems.
		Half Hard	Hard	Annealed	
inch (mm)	inch (mm)	bar+ (psi)	bar+ (psi)	bar+ (psi)	
¼" (6)	1/32" (0.6)	133 (1929)	161 (2335)	102 (1479)	
5/16" (8)	1/32" (0.6)	97 (1406)	118 (1711)	75 (1087)	
3/8" (10)	1/32" (0.6)	77 (1116)	93 (1348)	59 (855)	
7/16" (12)	1/32" (0.6)	63 (913)	76 (1102)	48 (696)	
½" (15)	1/32" (0.7)	58 (841)	71 (1029)	45 (652)	
11/16" (18)	1/32" (0.8)	56 (812)	67 (971)	43 (623)	
7/8" (22)	1/32" (0.9)	51 (739)	62 (899)	39 (565)	
1 1/8" (28)	1/32" (0.9)	40 (580)	48 (696)	31 (449)	
1 3/8" (35)	1/16" (1.2)	42 (609)	51 (739)	33 (478)	
1 11/16" (42)	1/16" (1.2)	35 (507)	43 (623)	27 (391)	

2 1/8" (54)	1/16" (1.2)	27 (391)	33 (478)	21 (304)	ECONOMICAL AND STRONG
2 5/8" (66.7)	1/16" (1.2)	20 (290)	27 (391)	17 (246)	
3 1/32" (76.1)	1/16" (1.5)	24 (348)	29 (420)	18 (261)	
4 5/16" (108)	1/16" (1.5)	17 (246)	20 (290)	13 (188)	
5 1/4" (133)	1/16" (1.5)	14 (203)	17 (246)	10 (145)	
6 1/4" (159)	1/16" (2.0)	15 (217)	18 (261)	12 (174)	
*Based on designated temp. at 149°F					

Size / Nom. Dia. (Outside)	Nom. Dia. (Outside)	Nom. Wall Thickness	Max. Working Pressures*		Usage: General purpose applications, sanitation, central heating, and above-ground services including drinking water supply, hot and cold-water systems.
inch (mm)	inch (mm)	inch (mm)	bar+ (psi)		
1/4" (6)	1/4" (6)	1/64" (0.5)	113 (1638)		
5/16" (8)	5/16" (8)	1/64" (0.5)	98 (1421)		
3/8" (10)	3/8" (10)	1/64" (0.5)	78 (1131)		
7/16" (12)	7/16" (12)	1/64" (0.5)	64 (928)		
1/2" (15)	1/2" (15)	1/64" (0.5)	50 (725)		
11/16" (18)	11/16" (18)	1/32" (0.6)	50 (725)		
7/8" (22)	7/8" (22)	1/32" (0.6)	41 (594)		
1 1/8" (28)	1 1/8" (28)	1/32" (0.6)	32 (464)		
1 3/8" (35)	1 3/8" (35)	1/32" (0.7)	30 (435)		
1 11/16" (42)	1 11/16" (42)	1/32" (0.8)	28 (406)		
2 1/8" (54)	2 1/8" (54)	1/32" (0.9)	25 (362)		
2 5/8" (66.7)	2 5/8" (66.7)	1/32" (1.0)	20 (290)		
3 1/32" (76.1)	3 1/32" (76.3)	1/16" (1.2)	19 (275)		
4 5/16" (108)	4 5/16" (108)	1/16" (1.2)	17 (264)		
5 1/4" (133)	5 1/4" (133)	1/16" (1.5)	16 (232)		
6 1/4" (159)	6 1/4" (159.5)	1/16" (1.5)	15 (217)		
*Based on designated temp. at 149°F					LOW-COST UTILITY RANGE

10.1.2 PVC - Standard Pipe Size Charts:

Pipe inch (mm)	OD		PN6 Wall Thickness		I/D inch (mm)	PN9 Wall Thickness		I/D inch (mm)	PN12 Wall Thickness		ID inch (mm)	PN12 Wall Thickness		I/D inch (mm)
	inch (mm)	inch (mm)	Min	Max		Min	Max		Min	Max		Min	Max	
1/2" (15)	53/64" (21.20)	27/32" (21.50)	-	-	-	-	-	-	-	-	-	1/16" (1.40)	1/16" (1.70)	23/32" (18.25)
3/4" (20)	1 3/64" (26.60)	1 1/16" (26.90)	-	-	-	-	-	-	1/16" (1.40)	1/16" (1.70)	15/16" (23.65)	1/16" (1.70)	5/64" (2.10)	29/32" (22.95)
1" (25)	1 5/16" (33.40)	1 1/64" (33.70)	-	-	-	1/16" (1.40)	1.70 (1/16")	1 13/64" (30.45)	1/16" (1.70)	5/64" (2.10)	1 11/64" (29.75)	3/32" (2.50)	1/8" (3.00)	1 7/64" (28.05)
1 1/4" (32)	1 21/32" (42.10)	1 43/64" (42.40)	-	-	-	1/16" (1.70)	2.10 (5/64")	1 33/64" (38.45)	3/32" (2.20)	7/64" (2.60)	1 15/32" (37.45)	1/8" (3.20)	9/64" (3.70)	1 25/64" (35.35)
1 1/2" (40)	1 57/64" (48.10)	1 19/32" (48.40)	1/16" (1.40)	1/16" (1.70)	1 51/64" (45.15)	5/64" (1.90)	2.10 (5/64")	1 47/64" (44.05)	3/32" (2.50)	1/8" (3.00)	1 11/16" (42.75)	9/64" (3.60)	11/64" (4.20)	1 19/32" (40.45)
2" (50)	2 3/8" (60.20)	2 3/8" (60.50)	1/16" (1.60)	5/64" (2.00)	2 15/64" (56.75)	3/32" (2.40)	2.80 (7/64")	2 11/64" (55.15)	1/8" (3.10)	9/64" (3.60)	2 7/64" (53.65)	3/16" (4.60)	13/64" (5.30)	1 63/64" (50.45)
2 1/2" (65)	75.20 (2 61/64")	2 31/32" (75.50)	-	-	-	-	-	-	5/32" (3.90)	11/64" (4.50)	2 41/64" (66.95)	-	-	-
3 3/16" (80)	3 31/64" (88.70)	3 33/64" (89.10)	3/32" (2.40)	7/64" (2.80)	3 19/64" (83.70)	9/64" (3.50)	4.10 (5/32")	3 13/64" (81.30)	3/16" (4.60)	13/64" (5.30)	3 7/64" (79.00)	-	-	-
4" (100)	4 31/64" (114.10)	4 33/64" (114.50)	1/8" (3.00)	9/64" (3.50)	4 1/4" (107.80)	11/64" (4.50)	5.20 (13/64")	4 1/8" (104.60)	15/64" (5.90)	17/64" (6.70)	4" (101.70)	-	-	-
5" (125)	5 33/64" (140.00)	5 17/32" (140.40)	-	-	-	7/32" (5.50)	6.30 (1/4")	5 1/16" (128.40)	9/32" (7.20)	5/16" (8.10)	4 59/64" (124.90)	-	-	-
6" (150)	6 19/64" (160.00)	6 5/16" (160.50)	11/64" (4.20)	11/64" (4.20)	6 61/64" (151.25)	1/4" (6.30)	7.10 (9/32")	6 25/32" (146.85)	21/64" (8.30)	23/64" (9.30)	6 39/64" (142.65)	15/32" (12.0)	33/64" (13.60)	6 16/64" (134.65)
7" (175)	7 7/8" (200.00)	7 57/64" (200.50)	-	-	-	9/32" (7.10)	8.00 (5/16")	7 19/64" (185.15)	-	-	-	-	-	-

7 1/4" (177)	6 31/32" (177.10)	6 63/64" (177.60)	-	-	-	-	-	-	23/64" (9.20)	13/32" (10.30)	6 7/32" (157.85)	-	-	-
8" (200)	8 55/64" (225.00)	8 7/8" (225.60)	7/32" (5.40)	15/64" (6.10)	8 27/64" (213.80)	5/16" (7.90)	11/32" (8.90)	8 13/64" (208.50)	13/32" (10.50)	29/64" (11.70)	8" (203.10)	-	-	-
8 7/8" (225)	9 27/32" (250.00)	9 7/8" (250.70)	-	-	-	-	-	-	29/64" (11.60)	33/64" (13.00)	8 57/64" (225.75)	-	-	-
10" (250)	11 1/32" (280.00)	11 3/8" (288.80)	-	-	-	-	-	-	33/64" (13.00)	37/64" (14.50)	10" (252.90)	-	-	-
12" (300)	12 13/32" (315.00)	12 7/16" (315.90)	-	-	-	-	-	-	37/64" (14.70)	41/64" (16.30)	11 13/64" (284.45)	-	-	-

10.1.3 Steel - Standard Pipe Size Charts:

Standard ANSI Pipe Size Chart for Carbon Steel and Stainless-Steel Pipe

Nominal Pipe Size	Outer Diameter	Wall Thickness	ANSI B 36.10 Carbon Steel	ANSI B 36.10 Carbon Steel	ANSI B 36.19 Stainless Steel
in (mm)	decimal in (mm)	decimal in (mm)	Wall Thckn.	Sch. Number	Sch. Number
1/8" (3)	0.405" (10)	0.05" (1.2)	-	-	10S
		0.07" (1.7)	STD	40	40S
		0.10" (2.4)	XS	80	80S
1/4" (6)	0.540" (14)	0.07" (1.7)	-	-	10S
		0.09" (2.2)	STD	40	40S
		0.12" (3)	XS	80	80S
3/8" (10)	0.675" (17)	0.07" (1.7)	-	-	10S
		0.10" (2.3)	STD	40	40S
		0.13" (3.2)	XS	80	80S
1/2" (15)	0.840" (21)	0.07" (1.7)	-	-	5S
		0.09" (2.1)	-	-	10S
		0.11" (3.2)	STD	40	40S
		0.15" (3.7)	XS	80	80S
		0.19" (4.7)	-	160	-
		0.30" (7.5)	XXS	-	-
3/4" (19)	1.050" (26)	0.07" (1.7)	-	-	5S
		0.09" (2.1)	-	-	10S
		0.12" (2.9)	STD	40	40S
		0.16" (3.9)	XS	80	80S
		0.22" (3.9)	-	160	-
		0.31" (7.8)	XXS	-	-
1" (25)	1.315" (33)	0.07" (1.7)	-	-	5S
		0.11" (3.2)	-	-	10S
		0.14" (3.4)	STD	40	40S
		0.18" (4.5)	XS	80	80S
		0.25" (6.4)	-	160	-
		0.36" (9.1)	XXS	-	-
1 1/4" (32)	1.660" (42)	0.07" (1.7)	-	-	5S
		0.11" (3.2)	-	-	10S
		0.14" (3.6)	STD	40	40S
		0.20" (4.9)	XS	80	80S
		0.25" (6.4)	-	160	-
		0.39" (9.7)	XXS	-	-
1 1/2" (139.7)	1.900" (48)	0.07" (1.7)	-	-	5S
		0.11" (3.2)	-	-	10S
		0.15" (3.7)	STD	40	40S
		0.20" (5.1)	XS	80	80S
		0.29" (7.1)	-	160	-
		0.40" (10.2)	XXS	-	-
2" (50)	2.375" (60)	0.07" (1.7)	-	-	5S
		0.11" (3.2)	-	-	10S

		0.16" (3.9)	STD	40	40S
		0.22" (5.5)	XS	80	80S
		0.35" (8.7)	-	160	-
		0.44" (11.1)	XXS	-	-
2 1/2" (65)	2.875" (73)	0.09" (2.1)	-	-	5S
		0.12" (3)	-	-	10S
		0.21" (5.2)	STD	40	40S
		0.28" (7)	XS	80	80S
		0.38" (9.5)	-	160	-
		0.56" (14)	XXS	-	-
3" (75)	3.500" (89)	0.09" (2.1)	-	-	5S
		0.12" (3)	-	-	10S
		0.22" (5.5)	STD	40	40S
		0.30" (7.6)	XS	80	80S
		0.44" (11.1)	-	160	-
		0.60" (15.2)	XXS	-	-
3 1/2" (85)	4.000" (101)	0.09" (2.1)	-	-	5S
		0.12" (3)	-	-	10S
		0.23" (5.7)	STD	40	40S
		0.32" (8.1)	XS	80	80S
		0.64" (16.2)	XXS	-	-
4" (100)	4.500" (114)	0.09" (2.1)	-	-	5S
		0.12" (3)	-	-	10S
		0.24" (6)	STD	40	40S
		0.34" (8.6)	XS	80	80S
		0.44" (12.7)	-	120	-
		0.54" (13.5)	-	160	-
		0.68" (17.1)	XXS	-	-
5" (125)	5.536" (140)	0.11" (3.2)	-	-	5S
		0.14" (3.4)	-	-	10S
		0.26" (6.6)	STD	40	40S
		0.38" (9.5)	XS	80	80S
		0.50" (12.7)	-	120	-
		0.63" (15.9)	-	160	-
		0.75" (19)	XXS	-	-
6" (150)	6.625" (168)	0.11" (3.2)	-	-	5S
		0.14" (3.4)	-	-	10S
		0.28" (7.1)	STD	40	40S
		0.44" (11)	XS	80	80S
		0.57" (14.3)	-	120	-
		0.72" (18.3)	-	160	-
		0.87" (3.4)	XXS	-	-
8" (200)	8.625" (219)	0.11" (3.2)	-	-	5S
		0.15" (21.9)	-	-	10S
		0.25" (6.4)	-	20	-
		0.28" (7)	-	30	-
		0.33" (11)	STD	40	40S
		0.41" (10.3)	-	60	-
		0.50" (12.7)	XS	80	80S
		0.60" (15.1)	-	100	-
		0.72" (18.3)	-	120	-
		0.82" (20.6)	-	140	-
		0.88" (22.2)	XXS	-	-
10" (250)	10.750" (273)	0.14" (3.4)	-	-	5S
		0.17" (4.2)	-	-	10S
		0.25" (6.4)	-	20	-
		0.31" (7.8)	-	30	-
		0.37" (9.3)	STD	40	40S
		0.50" (12.7)	XS	60	80S
		0.60" (15)	-	80	-

		0.72" (18.3)	-	100	-
		0.85" (21.4)	-	120	-
		1.00" (25.4)	XXS	140	-
12" (300)	12.750" (324)	0.16" (4)	-	-	5S
		0.18" (4.6)	-	-	10S
		0.25" (6.4)	-	20	-
		0.33" (8.4)	-	30	-
		0.38" (9.5)	-	-	40S
		0.41" (9.5)	-	40	-
		0.50" (10.3)	XS	-	80S
		0.57" (14.3)	-	60	-
		0.69" (17.5)	-	80	-
		0.85" (21.4)	-	100	-
		1.00" (25.4)	XXS	120	-
		1.13" (28.6)	-	140	-
		14" (350)	14.000" (355)	0.16" (4)	-
0.19" (4.8)	-			-	10S
0.25" (6.4)	-			10	-
0.32" (7.9)	-			20	-
0.38" (9.5)	-			30	-
0.44" (11.1)	-			40	-
0.50" (12.7)	XS			-	-
0.60" (15)	-			60	-
0.63" (15.9)	XXS			-	-
0.75" (19)	-			80	-
0.94" (23.8)	-			100	-
1.10" (27.8)	-			120	-
1.25" (31.8)	-			140	-
16" (400)	16.000" (406)	0.17" (4.2)	-	-	5S
		0.19" (4.8)	-	-	10S
		0.25" (6.4)	-	10	-
		0.32" (7.9)	-	20	-
		0.38" (9.5)	-	-	-
		0.50" (12.7)	STD	30	-
		0.66" (16.7)	XS	40	-
		0.85" (21.4)	-	60	-
		1.04" (26.2)	-	80	-
		1.22" (31)	-	100	-
		1.44" (36.6)	-	140	-
		1.55" (39.3)	-	160	-
		18" (450)	18.000" (457)	0.17" (4.2)	-
0.19" (4.8)	-			-	10S
0.25" (6.4)	-			10	-
0.32" (7.9)	-			20	-
0.38" (9.5)	STD			-	-
0.44" (11.1)	-			30	-
0.50" (12.7)	XS			-	-
0.57" (14.3)	-			40	-
0.75" (19)	-			60	-
0.94" (23.8)	-			80	-
1.16" (28.6)	-			100	-
1.38" (34.9)	-			120	-
1.57" (39.7)	-			140	-
20" (500)	20.000" (508)	0.19" (4.8)	-	-	5S
		0.22" (3.9)	-	-	10S
		0.25" (6.4)	-	10	-
		0.38" (9.5)	STD	20	-
		0.50" (12.7)	XS	30	-
		0.60" (15)	-	40	-

		0.82" (20.6)	-	60	-
		1.04" (26.2)	-	80	-
		1.29" (32.5)	-	100	-
		1.50" (38.1)	-	120	-
		1.75" (44.4)	-	140	-
		1.97" (50)	-	160	-
22" (550)	22.000" (559)	0.19" (4.8)	-	-	5S
		0.22" (3.9)	-	-	10S
		0.25" (6.4)	-	10	-
		0.38" (9.5)	STD	20	-
		0.50" (12.7)	-	40	-
		0.88" (22.2)	-	60	-
		1.13" (28.6)	-	80	-
		1.38" (34.9)	-	100	-
		1.63" (41.3)	-	120	-
		1.88" (41.3)	-	140	-
		2.22" (56.3)	-	160	-
24" (600)	24.000" (610)	0.22" (3.9)	-	-	5S
		0.25" (6.4)	-	-	10S
		0.38" (9.5)	-	10	-
		0.50" (12.7)	STD	20	-
		0.57" (14.3)	XS	-	-
		0.69" (17.5)	-	30	-
		0.97" (24.6)	-	60	-
		1.22" (31)	-	80	-
		1.54" (38.9)	-	100	-
		1.82" (46)	-	120	-
		2.07" (52.4)	-	140	-
		2.35" (59.5)	-	160	-
26" (650)	26.000" (660)	0.32" (7.9)	-	10	-
		0.38" (9.5)	STD	-	-
		0.50" (12.7)	XS	20	-
28" (700)	28.000" (711)	0.32" (7.9)	-	10	-
		0.38" (9.5)	STD	-	-
		0.50" (12.7)	XS	20	-
		0.63" (15.9)	-	30	-
30" (750)	30.000" (762)	0.25" (6.4)	-	-	5S
		0.32" (7.9)	-	10	10S
		0.38" (9.5)	STD	-	-
		0.50" (12.7)	XS	20	-
		0.63" (15.9)	-	30	-
		0.75" (19)	-	40	-
32" (800)	32.000" (813)	0.32" (7.9)	-	10	-
		0.38" (9.5)	STD	-	-
		0.50" (12.7)	XS	20	-
		0.63" (15.9)	-	30	-
		0.69" (17.5)	-	40	-
34" (850)	34.000" (864)	0.35" (8.7)	-	10	10S
		0.38" (9.5)	STD	-	-
		0.50" (12.7)	XS	20	-
		0.63" (15.9)	-	30	-
		0.69" (17.5)	-	40	-
36" (900)	36.000" (914)	0.32" (7.9)	-	10	10S
		0.38" (9.5)	STD	-	-
		0.50" (12.7)	XS	20	-
		0.63" (15.9)	-	30	-
		0.75" (19)	-	40	-
42" (1050)	42.000" (1067)	0.38" (9.5)	STD	-	-
		0.50" (12.7)	XS	20	-
		0.63" (15.9)	-	30	-
		0.75" (19)	-	40	-

48" (1200)	48.000" (1219)	0.38" (9.5)	-	-	-
		0.05" (1.2)	-	-	-

Table: Standard ANSI Pipe Size Data for Carbon Steel and Stainless-Steel Pipe

10.1.4 Cast Iron Pipe - Standard Pipe Size Charts: Standard Classes of Cast Iron Pipe

Nominal Pipe Size	Class A		Class B		Class C		Class D	
	Outer Diameter	Wall Thickness	Outer Diameter	Wall Thickness	Outer Diameter	Wall Thickness	Outer Diameter	Wall Thickness
	In (mm)	In (mm)	In (mm)	In (mm)	In (mm)	In (mm)	In (mm)	In (mm)
3" (76.2)	3.80" (97)	0.39" (10)	3.96" (101)	0.42" (11)	3.96" (101)	0.45" (11)	3.96" (101)	0.48" (12)
4" (101.6)	4.80" (122)	0.42" (11)	5.00" (127)	0.45" (11)	5.00" (127)	0.48" (12)	5.00" (127)	0.52" (13)
6" (152.4)	6.90" (175)	0.44" (11)	7.10" (180)	0.48" (12)	7.10" (180)	0.51" (13)	7.10" (180)	0.55" (14)
8" (203.2)	9.05" (230)	0.46" (12)	9.05" (230)	0.51" (13)	9.30" (236)	0.56" (14)	9.30" (236)	0.60" (15)
10" (254.0)	11.10" (282)	0.50" (13)	11.10" (282)	0.57" (14)	11.40" (290)	0.62" (16)	11.40" (290)	0.68" (17)
12" (304.8)	13.20" (335)	0.54" (14)	13.20" (335)	0.62" (16)	13.50" (343)	0.68" (17)	13.50" (343)	0.75" (19)
14" (355.6)	15.30" (388)	0.57" (14)	15.30" (389)	0.66" (17)	15.65" (398)	0.74" (19)	15.65" (17)	0.82" (21)
16" (406.4)	7.40" (188)	0.60" (15)	17.40" (442)	0.70" (18)	17.80" (452)	0.80" (20)	17.80" (452)	0.89" (23)
18" (457.2)	19.50" (495)	0.64" (16)	19.50" (495)	0.75" (20)	19.92" (506)	0.87" (22)	19.92" (506)	0.96" (24)
20" (508)	21.60" (549)	0.67" (17)	21.60" (549)	0.80" (20)	22.06" (560)	0.92" (23)	22.06" (560)	1.03" (26)
24" (609.6)	25.80" (655)	0.76" (19)	25.80" (655)	0.89" (23)	26.32" (669)	1.05" (27)	26.32" (669)	1.16" (29)
30" (762)	31.74" (806)	0.88" (22)	32.00" (813)	1.03" (26)	32.40" (823)	1.20" (30)	32.74" (832)	1.37" (35)
32" (812.8)	37.96" (964)	0.99" (25)	38.30" (973)	1.15" (29)	38.70" (983)	1.36" (35)	39.16" (995)	1.58" (40)
42" (1066.8)	44.20" (1123)	1.10" (28)	44.50" (1130)	1.28" (33)	45.10" (1146)	1.54" (39)	45.58" (1158)	1.78" (45)
48" (1219.2)	50.50" (1283)	1.26" (32)	50.80" (1290)	1.42" (36)	51.40" (1306)	1.71" (43)	51.98" (1320)	1.99" (50)
54" (1371.6)	56.66" (1439)	1.35" (34)	57.10" (1450)	1.55" (39)	57.80" (1468)	1.90" (48)	58.40" (1483)	2.23" (57)
60" (1524.0)	62.80" (1595)	1.39" (35)	63.40" (1610)	1.67" (42)	64.20" (1631)	2.00" (51)	64.80" (1646)	2.38" (60)
72" (1828.8)	75.34" (1914)	1.62" (41)	76.00" (1930)	1.95" (42)	76.88" (1953)	2.39" (61)	-	-
84" (2133.6)	87.54" (2224)	1.72" (44)	88.50" (2248)	2.22" (57)	-	-	-	-

Nominal Pipe Size	Class E		Class F		Class G		Class H	
	Outer Diameter	Wall Thickness	Outer Diameter	Wall Thickness	Outer Diameter	Wall Thickness	Outer Diameter	Wall Thickness
	In (mm)	In (mm)	In (mm)	In (mm)	In (mm)	In (mm)	In (mm)	In (mm)
6" (152.4)	7.22" (183)	0.58" (15)	7.22" (183)	0.61" (15)	7.38" (187)	0.65" (17)	7.38" (187)	0.69" (18)
8" (203.2)	9.42" (239)	0.66" (17)	9.42" (239)	0.66" (17)	9.60" (244)	0.75" (19)	9.60" (244)	0.80" (20)
10" (254.0)	11.60" (295)	0.74" (19)	11.60" (295)	0.80" (20)	11.84" (301)	0.86" (22)	11.84" (301)	0.92" (23)
12" (304.8)	13.78" (350)	0.82" (21)	13.78" (350)	0.89" (23)	14.08" (358)	0.97" (25)	14.08" (358)	1.04" (26)
14" (355.6)	15.98" (406)	0.90" (23)	15.98" (406)	0.99" (25)	16.32" (415)	1.07" (27)	16.32" (415)	1.16" (29)
16" (406.4)	18.16" (461)	0.90" (23)	18.16" (462)	1.08" (27)	18.54" (471)	1.18" (30)	18.54" (471)	1.27" (32)
18" (457.2)	20.34" (517)	1.07" (27)	20.34" (517)	1.17" (30)	20.78" (528)	1.28" (33)	20.78" (528)	1.39" (35)
20" (508)	22.54" (573)	1.15" (29)	22.54" (573)	1.27" (32)	23.02" (585)	1.39" (35)	23.02" (585)	1.51" (38)
24" (609.6)	26.90" (683)	1.31" (33)	26.90" (683)	1.45" (37)	27.76" (705)	1.75" (44)	27.76" (705)	1.88" (48)
30" (762)	33.10" (841)	1.55" (39)	33.46" (850)	1.73" (44)	-	-	-	-
32" (812.8)	39.60" (1006)	1.80" (46)	40.04" (1017)	2.02" (51)	-	-	-	-

10.1.5 Ductile Iron Pipe - Standard Pipe Size Charts:

Nominal Pipe Size	Outer Diameter	Pipe Wall Thickness						
		Class	Class	Class	Class	Class	Class	Class
		50	51	52	53	54	55	56
in (mm)	in (mm)	in (mm)	in (mm)	in (mm)	in (mm)	in (mm)	in (mm)	in (mm)
3" (76.2)	3.96" (100)	-	0.25" (6)	0.28" (7)	0.31" (8)	0.43" (11)	0.37" (9)	0.40" (10)

4" (101.6)	4.80" (121)	-	0.26" (7)	0.29" (7)	0.32" (8)	0.45" (11)	0.38" (10)	0.41" (10)
6" (152.4)	6.90" (175)	0.25" (6)	0.28" (7)	0.31" (8)	0.34" (7)	0.37" (9)	0.40" (10)	0.43" (11)
8" (203.2)	9.05" (229)	0.27" (7)	0.30" (8)	0.33" (8)	0.36" (9)	0.39" (10)	0.42" (11)	0.45" (11)
10" (254)	11.10" (281)	0.29" (7)	0.32" (8)	0.35" (9)	0.38" (10)	0.44" (11)	0.47" (12)	-
12" (304.8)	13.20" (335)	0.31" (8)	0.34" (9)	0.37" (9)	0.40" (10)	0.43" (11)	0.46" (12)	0.49" (12)
14" (355.6)	15.30" (388)	0.33" (8)	0.36" (9)	0.39" (10)	0.42" (11)	0.45" (11)	0.48" (12)	0.51" (13)
16" (406.4)	17.40" (441)	0.34" (9)	0.37" (9)	0.40" (10)	0.43" (11)	0.46" (12)	0.49" (12)	0.52" (13)
18" (457.2)	19.50" (495)	0.35" (9)	0.38" (10)	0.41" (10)	0.44" (11)	0.47" (12)	0.50" (13)	0.53" (13)
20" (508)	21.60" (548)	0.36" (9)	0.39" (10)	0.42" (11)	0.45" (11)	0.48" (12)	0.51" (13)	0.54" (14)
24" (609.6)	25.80" (655)	0.38" (10)	0.41" (10)	0.44" (11)	0.47" (12)	0.50" (13)	0.53" (13)	0.56" (14)
30" (762)	32.00" (812)	-	-	-	0.51" (13)	0.55" (13)	0.59" (15)	0.63" (16)
32" (812.8)	38.30" (972)	-	-	-	0.58" (15)	0.63" (16)	0.68" (17)	0.73" (19)
42" (1066.8)	44.50" (1130)	-	-	-	0.65" (16)	0.71" (18)	0.77" (20)	0.83" (21)
48" (1219.2)	50.80" (1290)	-	-	-	0.72" (18)	0.79" (20)	0.86" (22)	0.93" (24)
54" (1371.6)	57.10" (1450)	-	-	-	0.81" (21)	0.89" (23)	0.97" (25)	1.05" (27)

10.2 Tables: Sound Speed

10.2.1 Solids: Sound Speed Data

Material	Sound Speed		Sound Speed	
	Shear Wave (25(d))		Long. Wave (25(d))	
	ft/s	m/s	in/us	mm/us
Steel, 1% Carbon, hardened	10,335	3,150	0.2315	5.88
Carbon Steel	10,598	3,230	0.2319	5.89
Mild Steel	10,614	3,235	0.2319	5.89
Steel,1% Carbon	10,565	3,220	-	-
302 Stainless Steel	10,236	3,120	0.224	5.690
303 Stainless Steel	10,236	3,120	0.222	5.640
304 Stainless Steel	10,306	3,141	0.233	5.920
304L Stainless Steel	10,073	3,070	0.228	5.790
316 Stainless Steel	10,735	3,272	0.225	5.720
347 Stainless Steel	10,512	3,095	0.225	5.720
Aluminum	10,171	3,100	0.2488	6.32
Aluminum (rolled)	9,974	3,040	-	-
Copper	7,415	2,260	0.1835	4.66
Copper (annealed)	7,628	2,235	-	-
Copper (rolled)	7,448	2,270	-	-
CuNi (70%Cu 30%Ni)	8,334	2,540	0.1980	5.03
CuNi (90%Cu 10%Ni)	6,759	2,060	0.1579	4.01
Brass (Naval)	6,923	2,120	0.1744	4.43
Gold (hard-drawn)	3,937	1,200	0.1276	3.24
Inconel	9,909	3,020	0.2291	5.82
Iron (electrolytic)	10,630	3,240	0.2323	5.90
Iron (Armco)	10,630	3,240	0.2323	5.90
Ductile Iron	9,843	3,000	-	-
Cast Iron	8,203	2,500	0.1791	4.55
Monel	8,924	2,720	0.2106	5.35
Nickel	9,712	2,960	0.2217	5.63
Tin,rolled	5,479	1,670	0.1307	3.32
Tintanium	10,253	3,125	0.2402	6.10
Tungsten,annealed	9,482	2,890	0.2039	5.18
Tungsten,drawn	8,661	2,640	-	-

Tungsten, carbide	13,058	3,980	-	-
Zinc, rolled	8,005	2,440	0.1642	4.17
Glass, Pyrex	10,761	3,280	0.2209	5.61
Glass, heavy silicate flint	7,808	2,380		
Glass, light borate crown	9,318	2,840	0.2071	5.26
Nylon	3,772	1,150	0.0945	2.40
Nylon, 6-6	3,510	1,070	-	-
Polyethylene (LD)	-	-	0.0909	2.31
Polyethylene (LD)	1,772	540	0.0764	1.94
PVC, CPVC	3,477	1,060	0.0945	2.40
Acrylic	4,690	1,430	0.1075	2.73
Asbestos Cement	-	-	0.0866	2.20
Tar Epoxy	-	-	0.0787	2.00
Mortar	-	-	0.0984	2.50
Rubber	-	-	0.00748	1.90

10.2.2 Water: Sound Speed

Sound Speed in Water at atmosphere pressure. Unit T (Deg °F) V (ft/s)

t	v	t	v	t	v	t	v
32.00	4600.72	77.00	4910.10	122.00	5060.70	167.00	5102.03
33.80	4617.13	78.80	4918.64	123.80	5063.98	168.80	5101.71
35.60	4633.20	80.60	4927.17	125.60	5067.59	170.60	5101.38
37.40	4648.62	82.40	4935.37	127.40	5070.54	172.40	5101.05
39.20	4664.04	84.20	4943.24	129.20	5073.49	174.20	5100.39
41.00	4678.81	86.00	4950.79	131.00	5076.44	176.00	5099.74
42.80	4693.24	87.80	4958.33	132.80	5079.07	177.80	5099.08
44.60	4707.35	89.60	4965.55	134.60	5081.69	179.60	5098.10
46.40	4721.46	91.40	4972.77	136.40	5083.99	181.40	5097.11
48.20	4734.91	93.20	4979.33	138.20	5086.29	183.20	5095.80
50.00	4748.03	95.00	4985.89	140.00	5088.25	185.00	5094.49
51.80	4760.83	96.80	4992.45	141.80	5090.22	186.80	5093.18
53.60	4773.29	98.60	4998.36	143.60	5091.86	188.60	5091.86
55.40	4785.76	100.40	5004.27	145.40	5093.50	190.40	5090.22
57.20	4797.57	102.20	5010.17	147.20	5095.14	192.20	5088.58
59.00	4809.06	104.00	5015.75	149.00	5096.46	194.00	5086.61
60.80	4820.54	105.80	5021.00	150.80	5097.44	195.80	5084.65
62.60	4831.69	107.60	5026.25	152.60	5098.43	197.60	5082.68
64.40	4842.52	109.40	5031.17	154.40	5099.41	199.40	5080.38
66.20	4852.69	111.20	5035.76	156.20	5100.07	201.20	5077.10
68.00	4863.19	113.00	5040.35	158.00	5100.72	203.00	5075.79
69.80	4873.03	114.80	5044.95	159.80	5101.38	204.80	5073.16
71.60	4882.55	116.60	5048.88	161.60	5101.71	206.60	5070.87
73.40	4892.06	118.40	5053.15	163.40	5101.71	208.40	5067.91
75.20	4901.25	120.20	5056.76	165.20	5102.03	210.20	5065.29

10.2.3 Liquids: Sound Speed
Sound Speed in Liquids

Substance	Chemical Formula	All data given at 77°F (25°C) unless otherwise noted				
		Specific Gravity	Sound Speed		Kinematic Viscosity x10-6	
			ft/s	m/s	ft ² /s	m ² /s
Acetic anhydride (22)	(CH ₃ CO) ₂ O	1.082 (68°F)	3,871.4	1,180	8.274	0.769
Acetic acid, anhydride (22) (CH ₃ CO) ₂ O	(CH ₃ CO) ₂ O	1.082 (68°F)	3,871.4	1,180	8.274	0.769
Acetic acid, Nitrile	C ₂ H ₃ N	0.783	4,232.3	1,290	4.745	0.441
Acetic acid, Ethyl Ester (33)	C ₄ H ₈ O ₂	0.901	3,559.7	1,085	5.025	0.467
Acetic acid, Methyl Ester	C ₃ H ₆ O ₂	0.934	3,973.1	1,211	4.379	0.407
Acetone	C ₃ H ₆ O	0.791	3,851.7	1,174	4.293	0.399
Acetonitrile	C ₂ H ₃ N	0.783	4,232.3	1,290	4.745	0.441
Acetylacetone	C ₆ H ₁₀ O ₂	0.729	4,589.9	1,399	-	-
Acetylen Dichloride	C ₂ H ₂ CL ₂	1.26	3,330.1	1,015	4.304	0.400
Acetylen Tetrabromide (47)	C ₂ H ₂ Br ₄	2.966	3,369.4	1,027	-	-
Acetylen Tetrachloride (47)	C ₂ H ₂ CL ₄	1.595	3,763.1	1,147	12.438 (59°F)	1.156 (15°C)
Alcohol	C ₂ H ₆ O	0.789	3,960	1,207	15.02	1.396
Alkazene-13	C ₁₅ H ₂₄	0.86	4,320.9	1,317	-	-
Alkazene-25	C ₁₀ H ₁₂ CL ₂	1.20	4,288.1	1,307	-	-
2-Amino-Ethanol	C ₂ H ₇ NO	1.018	5,656.2	1,724	-	-
2-Aminotolidine (46)	C ₇ H ₉ N	0.999 (68°F)	5,308.4	1,618	47.279 (68°F)	4.394 (20°C)
4-Aminotolidine (46)	C ₇ H ₉ N	0.999 (113°F)	4,855.6	1,480	20.045 (122°F)	1.863 (50°C)
Ammonia (35)	NH ₃	0.771	5,672.6 (-27°F)	1,729 (-33°C) (d)	3.141 (-27°F)	0.292 (-33°C)
Amorphous Polyolefin	-	0.98	3158.2 (374°F)	962.6 (190°C)	286.000	26,600
t-Amyl Alcohol	C ₅ H ₁₂ O	0.81	3,950.1	1,204	47.064	4.374
Aminobenzene (41)	C ₆ H ₅ NO ₂	1.022	5,377.3	1,639	39.058	3.63
Aniline (41)	C ₆ H ₅ NO ₂	1.022	5,377.3	1,639	39.058	3.63
Argon (45)	Ar	1.400 (-306.4°F)	2798.6 (-306°F)	853 (-188°C)	-	-
Azine	C ₆ H ₅ N	0.982	4,642.4	1,415	10.673 (68°F)	0.992 (20°C)
Benzene (29,40,41)	C ₆ H ₆	0.879	4,284.8	1,306	7.65	0.711
Benzol (29,40,41)	C ₆ H ₆	0.879	4,284.8	1,306	7.65	0.711
Bromine (21)	Br ₂	2.928	2,916.7	889	3.475	0.323
Bromo-Benzene (46)	C ₆ H ₅ Br	1.522	3,838.6 (68°F)	1,170 (20°C)	7.456	0.693
1-Bromo-Butane (46)	C ₄ H ₉ Br	1.276 (68°F)	3,343.2 (68°F)	1,019 (20°C)	5.272 (59°F)	0.49 (15°C)
Bromo-Ethane (46)	C ₂ H ₅ Br	1.460 (68°F)	2,952.8 (68°F)	900 (20°C)	2.959	0.275
Bromoform (46,47)	CHBr ₃	2.89 (68°F)	3,011.8	918	7.037	0.654
n-Butane (2)	C ₄ H ₁₀	0.601 (32°F)	3,559.7 (23°F)	1,085 (-5°C)	-	-
2-Butanol	C ₄ H ₁₀ O	0.81	4,068.2	1,240	34.851	3.239
Sec-Butyl Alcohol	C ₄ H ₁₀ O	0.81	4,068.2	1,240	34.851	3.239
n-Butyl Bromide (46)	C ₄ H ₉ Br	1.276 (68°F)	3,343.2 (68°F)	1,019 (20°C)	5.272 (59°F)	0.49 (15°C)
n-Butyl Chloride (22,46)	C ₄ H ₉ CL	0.887	3,740.2	1,140	5.692 (59°F)	0.529 (15°C)
Tert Butyl Chloride	C ₄ H ₉ CL	0.84	3,228.3	984	6.95	0.646
Butyl Oleate	C ₂₂ H ₄₂ O ₂	-	4,606.3	1,404	-	-
2,3 Butylene Glycol	C ₄ H ₁₀ O ₂	1.019	4,808.8	1,484	-	-
Cadmium (7)	CD	-	7,341.5 (752°F)	2,237.7 (400°C)	14.579 (824°F)	1.355cp (440°C)
Carbinol (40,41)	CH ₄ O	0.791 (68°F)	3,530.2	1,076	7.478	0.695
Carbitol	C ₆ H ₁₄ O ₃	0.988	4,783.5	1,458	-	-
Carbon Dioxide (26)	CO ₂	1.101 (-98.6°F)	2,752.6 (-35°F)	839 (-37°C)	1.474 (-35°F)	0.137 (-37°C)
Carbon Disulphide	CS ₂	1.261 (71.6°F)	3,769.7	1,149	2.991	0.278
Carbon Tetrachloride (33, 35, 47)	CCL ₄	1.595 (68°F)	3038.1	929	6.531	0.607
Carbon tetrafluoride (14) (Freon 14)	CF ₄	1.75 (-302°F)	2,871.5 (-238°F)	875.2 (-150°C)	-	-
Cetane (23)	C ₁₆ H ₃₄	0.773 (68°F)	4,389.8	1,338	46.483	4.32
Chloro-Benezene	C ₆ H ₅ CL	1.106	4,176.5	1,273	7.768	0.722

1-Chloro-Butane (22,46)	C ₄ H ₉ CL	0.887	3,740.2	1,140	5.692 (59°F)	0.529 (15°C)
Chloro-DiFluoromethane (3) (Freon 22)	CHCLF ₂	1.491 (-156.2°F)	2,932.7 (-58°F)	893.9 (-50°C)	-	-
Chloroform (47)	CHCL ₃	1.489	3,211.9	979	5.918	0.55
1-Chloro-propane (47)	C ₃ H ₇ CL	0.892	3,471.1	1,058	4.067	0.378
Chlorotrifluoromethane (5)	C ₃ H ₇ CL	-	2,375.3 (-116°F)	724 (-82°C)	-	-
Cinnamaldehyde	C ₉ H ₈ O	1.112	5,098.4	1,554	-	-
Cinnamic aldehyde	C ₉ H ₈ O	1.112	5,098.4	1,554	-	-
Colamine	C ₂ H ₇ NO	1.018	5,656.2	1,724	-	-
o-Cresol (46)	C ₇ H ₈ O	1.047 (68°F)	5,055.8 (68°F)	1,541 (20°C)	46.16 (104°F)	4.29 (40°C)
m-Cresol (46)	C ₇ H ₈ O	1.034 (68°F)	4,923.1 (68°F)	1,500 (20°C)	64.334 (104°F)	5.979 (40°C)
Cyanomethane	C ₂ H ₃ N	0.783	4,232.3	1,290	4.745	0.441
Cyclohexane (15)	C ₆ H ₁₂	0.779 (68°F)	4,094.5	1,248	14.095 (63°F)	1.31 (17°C)
Cyclohexanol	C ₆ H ₁₂ O	0.962	4,770.3	1,454	0.764 (63°F)	0.071 (17(d))
Cyclohexanone	C ₆ H ₁₀ O	0.948	4,668.6	1,423	-	-
Decane (46)	C ₁₀ H ₂₀	0.730	4,107.6	1,252	13.55 (68°F)	1.26 (20°C)
1-Decene (27)	C ₁₀ H ₂₀	0.746	4,051.8	1,235	-	-
n-Decene (27)	C ₁₀ H ₂₀	0.746	4,051.8	1,235	-	-
Diacetyl	C ₄ H ₆ O	0.99	4,055.1	1,236	-	-
Diamylamine	C ₁₀ H ₂₃ N	-	4,120.7	1,256	8.5 (68°F)	-
1,2Dibromo-Ethane (47)	C ₂ H ₄ Br ₂	2.18	3,264.4	995	-	0.79 (20°C)
trans-1,2-Dibromoethene (47)	C ₂ H ₂ Br ₂	2.231	3,067.6	935	-	-
Dibutylphthalate	C ₈ H ₂₂ O ₄	-	4,619.4	1,408	-	-
Dichloro-t-Butyl Alcohol	C ₄ H ₈ Cl ₂ O	-	4,278.2	1,304	-	-
2,3Dichlorodioxane	C ₂ H ₆ Cl ₂ O ₂	-	4,563.6	1,391	-	-
Dichloedifluoromethane (3) (Freon12)	CCl ₂ F ₂	1.516 (104°F)	2,539.7	774.1	-	-
1,2Dichloro Ethane (47)	C ₂ H ₂ Cl ₂	1.253	3,914	1,193	6.563	0.61
cis1,2-Dichloro-ethene (3, 47)	CHCl ₂ F	1.284	3,481	1,061	-	-
trans1,2-Dichloro-Ethene (3,47)	C ₄ Cl ₂ F ₆	1.257	3,313.6	1,010	-	-
Dichloro-Fluoromethane (3) (Freon21)	C ₄ H ₈ Cl ₂	1.426 (32°F)	2,923.2 (32°F)	891 (0°C)	-	-
1-2-Dichlorohexafluoro-Cyclobutane (47)	CClF ₂ -CClF ₂	1.654	2,914.9	669	-	-
1-3-Dichloro-isobutane	C ₄ H ₁₀ O	1.14	4,002.6	1,220	-	-
Dichloro Methane (3)	C ₄ H ₁₀ O ₃	1.327	3,510.5	1,070	3.335	0.31
1,1-Dichloro-1,2,2,2 Tetra Fluoromethane	C ₆ H ₁₄ O ₃	1.455	2,182.7 (14°F)	665.3 (-10°C)	-	-
Diethyl Ether	C ₄ H ₉ NO	0.713	3,231.6	985	3.346	0.311
Diethylene Glycol	C ₄ H ₈ (NF ₂) ₂	1.116	5,203.4	1,586	-	-
Diethylene Glycol Monoethyl Ether	C ₄ H ₉ (NF ₂) ₂	0.988	4,783.5	1,458	-	-
Diethylenimide Oxide	C ₃ H ₆ (NF ₂) ₂	1.00	4,731	1,442	-	-
1,2-bis (DiFluoramino) Butane (43)	C ₁₀ H ₂₃ N	1.216	3,280.8	1,000	-	-
1,2-bis (DiFluoramino)-2-Methylpropane (43)	C ₂ H ₄ Br ₂	1.213	2,952.8	900	-	-
1,2-bis (DiFluoramino) Propane (43)	C ₂ H ₂ Br ₂	1.265	3,149.6	960	-	-
2,2-bis (Difluoromino) 2 Propane (43)	C ₃ H ₆ (NF ₂) ₂	1.254	2920	890	-	-
2,2-Dihydroxydiethyl Ether	C ₄ H ₁₀ O ₃	1.116	5,2034	1,586	-	-
Dihydroxyethane	C ₂ H ₆ O ₂	1.113	5,439.6	1,658	-	-
1,3-Dimethyl-Benzene (46)	C ₈ H ₁₀	0.868 (59°F)	4,406.2 (68°F)	1,343 (20°C)	8.059 (59°F)	0.749 (15°C)
1,2-Dimethyl-Benzene (29,46)	C ₈ H ₁₀	0.897 (68°F)	4,368.4	1,331.5	9.716 (68°F)	0.903 (20°C)
1,4-Dimethyl-Benzene (46)	C ₈ H ₁₀	-	4,376.6 (68°F)	1,334v (20°C)	7.123	0.662
2,2Dimethyl-Butane (29,33)	C ₆ H ₁₄	0.649 (68°F)	3,540	1,079	-	-
Dimethyl Ketone	C ₃ H ₆ O	0.791	3,851.7	1,174	4.293	0.399

Dimethylpentane (47)	C ₇ H ₁₆	0.674	3,487.5	1,063	-	-
Dimethylphthalate	C ₈ H ₁₀ O ₄	1.2	4,799.9	1,463	-	-
Diiodo-Methane	CH ₂ I ₂	3.235	3,215.2	980	-	-
Dioxane	C ₄ H ₈ O ₂	1.033	4,514.4	1,376	-	-
Dodecane (23)	Cl ₂ H ₂₆	0.749	4,196.2	1,279	19.368	1.80
1,2Ethanediol	C ₂ H ₆ O ₂	1.113	5,439.6	1,658	-	-
Ethanenitrile	C ₂ H ₃ N	0.783	4,232.3	1,290	4.745	0.441
Ethanoic Anhydride (22)	(CH ₃ CO) ₂ O	1.082	3,871.4	1,180	8.274	0.769
Ethanol	C ₂ H ₆ O	0.789	3,690	1,207	14.956	1.39
Ethanol Amide	C ₂ HNO	1.018	5,656.2	1,338 (20°C)	-	-
Ethoxyethane	C ₄ H ₁₀ O	0.713	3,231.6	900 (20°C)	3.346	0.311
Ethyl Acetate (33)	C ₄ H ₈ O ₂	0.901	3,559.7	876 (20°C)	5.263	0.489
Ethyl Alcohol	C ₂ H ₆ O	0.789	3,960	890	15.020	1.396
Ethyl Benzene (46)	C ₈ H ₁₀	0.867 (68°F)	4,389.8 (68°F)	1,586	8.575 (63°F)	0.797 (17°C)
Ethyl Bromide (46)	C ₂ H ₅ Br	1.456 (68°F)	2,952.8 (68°F)	1,658	2.959 (68°F)	0.275 (20°C)
Ethyl iodide (46)	C ₂ H ₅ I	1.950 (68°F)	2874 (68°F)	1,343 (20°C)	3.12	0.29
Ether	C ₄ H ₁₀ O	0.713	3231.6	985	3.346	0.311
Ethyl Ether	C ₄ H ₁₀ O	0.713	3231.6	985	3.346	0.311
Ethylene Bromide (47)	C ₂ H ₄ Br ₂	2.18	3264.4	995	8.5	0.79
Ethylene Chloride (47)	C ₂ H ₄ Cl ₂	1.253	3914	1,193	6.563	0.61
Ethylene Glycol	C ₂ H ₆ O ₂	1.113	5439.6	1,658	185.158 (68°F)	17.208 (20°C)
d-Fenochone	C ₁₀ H ₁₆ O	0.974	4330.7	1,320	2.367	0.22
d-2-Fenecanone	C ₁₀ H ₁₆ O	0.974	4330.7	1,320	2.367	0.22
Fluorine	F	0.545 (-289.4°F)	1322.2 (-225°F)	403 (-143(d))	-	-
Fluoro-Benzene (46)	C ₆ H ₅ F	1.024 (68°F)	3900.9	1,189	6.283 (68°F)	0.584 (20°C)
Formaldehyde, Methylester	C ₂ H ₄ O ₂	0.974	3697.5	1,127	-	-
Formamide	CH ₃ NO	1.134 (68°F)	5321.5	1,622	31.311	2.91
Formic Acid, Amide	CH ₃ NO	1.134 (68°F)	5321.5	1,622	31.311	2.91
Freon R12	-	-	2540	774.2	-	-
Furfural	C ₅ H ₄ O ₂	1.157	4737.5	1,444	-	-
Furfuryl Alcohol	C ₅ H ₆ O ₂	1.135	4757.5	1,450	-	-
Fural	C ₅ H ₄ O ₂	1.157	4737.5	1,444	-	-
2-Furaldehyde	C ₅ H ₄ O ₂	1.157	4737.5	1,444	-	-
2-Furancarboxaldehyde	C ₅ H ₄ O ₂	1.157	4737.5	1,444	-	-
2-Furyl-Methanol	C ₅ H ₆ O ₂	1.135	4757.2	1,450	-	-
Gallium	Ga	6.095	9416 (86°F)	2,870 (30°C)	-	-
Glycerin	C ₃ H ₈ O ₃	1.26	6246.7	1,904	-	757.1
Glycerol	C ₃ H ₈ O ₃	1.26	6246.7	1,904	-	757.1
Glycol	C ₂ H ₆ O ₂	1.113	5439.6	1658	8,081.836	-
50%Glycol/50%h2O	-	-	5,177	1,578	8,081.836	-
Helium (45)	He ₄	0.125 (-516.2°F)	600.4 (-452°F)	183 (-269°C)	269	0.025
Heptane (22,23)	C ₇ H ₁₆	0.684 (408.2°F)	3,710.6	1,131	6.434 (68°F)	0.598 (209°C)
n-Heptane (29,33)	C ₇ H ₁₆	0.684 (68°F)	3,871.3	1,180	-	-
Hexachloro-Cyclopentadiene (47)	C ₅ Cl ₆	1.7180	3,773	1,150	-	-
Hexadecane (23)	C ₁₆ H ₃₄	0.773 (68°F)	4,389.8	1,338	46.483 (68°F)	4.32 (20°C)
Hexalin	C ₆ H ₁₂ O	0.962	4,770.3	1,454	760.882 (63°F)	70.69 (17°C)
Hexane (16,22,23)	C ₆ H ₁₄	0.659	3,648.3	1,112	4.798	0.446
n-Hexane (29,33)	C ₆ H ₁₄	0.649 (68°F)	3,540	1,079	-	-
2,5Hexanedione	C ₆ H ₁₀ O ₂	0.729	4,589.9	1,399	-	-
n-Hexanol	C ₆ H ₁₄ O	0.819	4,265.1	1,300	-	-
Hexahydrobenzene (15)	C ₆ H ₁₂	0.779	4,094.5	1,248	14.095 (63°F)	1.31 (179°C)
Hexahydrophenol	C ₆ H ₁₂ O	0.962	4,770.3	1,454	-	-
Hexamethylene (15)	C ₆ H ₁₂	0.779	4,094.5	1,248	14.095 (63°F)	1.31 (17°C)
Hydrogen (45)	H ₂	0.071 (-492.8°F)	3,894.4 (-429°F)	1,187 (-256°C)	0.032 (-429°F)	0.003 (-256°C)
2-Hydroxy-Toluene (46)	C ₇ H ₈ O	1.047 (68°F)	5,055.8 (68°F)	1,541 (20°C)	46.16 (104°F)	4.29 (40°C)
3-Hydroxy-Toluene (46)	C ₆ H ₅ I	1.034 (68°F)	4,921.3 (68°F)	1,500 (20°C)	64.334 (104°F)	5.979 (40°C)
Iodo-Benzene (46)	C ₂ H ₅ I	1.823	3,654.9 (68°F)	1,114 (20(d))	-	0.954
Iodo-Ethane (46)	CH ₃ I	1.950 (68°F)	2,874 (68°F)	876 (20°C)	3.12	0.29
Iodo-Methane	C ₆ H ₁₂ O	2.28 (68°F)	3,208.7	978	2.27	0.211
Isobutylacetate (22)	He ₄	-	3,871.4 (81°F)	1,180 (27°C)	-	-

Isobutanol	C ₄ H ₁₀ O	0.81 (68°F)	3,976.4	1,212	-	-
Iso-Butane	-	-	4002	1,219.8	-	-
Lsopentane (36)	C ₅ H ₁₂	0.62 (68°F)	3,215.2	980	3.658	0.34
Lsopropano (46)	C ₃ H ₈ O	0.758 (68°F)	3,838.6 (68°F)	1,170 (20°C)	29.245	2.718
Lsopropyl Alcohol (46)	C ₃ H ₈ O	0.758 (68°F)	3,838.6 (68°F)	1,170 (20°C)	29.245	2.718
Kerosene	-	0.81	4,343.8	1,324	-	-
Ketohexamethylene	C ₆ H ₁₀ O	0.948	4,668.6	1,423	-	-
Lithium Fluoride (42)	LiF	-	8,152.9 (1652°F)	2,485 (900°C)	-	-
Mercury (45)	Hg	13.594	4,753.9 (75°F)	1,449 (24°C)	1.226	0.114
Mesityloxiide	C ₆ H ₁₆ O	0.85	4,297.9	1,310	-	-
Methane (25,28,38,39)	CH ₄	0.162 (-192.2°F)	1,328.7 (-128°F)	405 (-89°C)	-	-
Methano (40,41)	CH ₄ O	0.791 (68°F)	3,530.2	1,076	7.748	0.695
Methyl Acetate	C ₃ H ₆ O ₂	0.934	3,973.1	1,211	4.379	0.407
o-Methyaniline (46)	C ₇ H ₉ N	0.999 (68°F)	5,308.4	1,618	47.279 (68°F)	4.394 (20°C)
4-Methyaniline (46)	C ₇ H ₉ N	0.966 (45(d))	4,855.6	1,480	20.095 (122°F)	1.863 (50°C)
Methyl alcohol (40,44)	CH ₄ O	0.791 (20(d))	3,530.2	1,076	7.478	0.695
Methyl Benzene (16,52)	C ₇ H ₈	0.867	4,357 (68°F)	1,328 (20°C)	7.144	0.644
2-Methyl-Butane (36)	C ₅ H ₁₂	0.62 (68°F)	3,215.2	980	3.658	0.34
Methy Carbinol	C ₂ H ₆ O	0.789	3,960	1,207	-	1.396
Methy-Chloroform (47)	C ₂ H ₃ Cl ₃	1.33	3,231.6	985	9.705 (68°F)	0.902 (20°C)
Methyl-Cyanide	C ₂ H ₃ N	0.783	4,232.3	1,290	4.745	0.441
3-Methyl Cyclohexanol	C ₇ H ₁₄ O	0.92	4,593.2	1,400	-	-
Oil, Diesel	-	0.80	4,101	1,250	-	-
Oil, Field Gravity	-	0.99	4,872	1,485	-	-
Oil (Lubricating x200)	-	-	5,019.9	1,530	-	-
Oil (Olive)	-	0.912	4,694.9	1,431	1,076.36	100
Oil (Peanut)	-	0.936	4,783.5	1,458	-	-
Oil (Sperm)	-	0.88	4,724.2	1,440	-	-
Oil, 6	-	-	4,951 (72°F)	1,509 (22°C)	-	-
2,2-Oxydiethanol	CH ₁₀ O ₃	1.116	5,203.4	1,586	-	-
Oxygen (45)	O ₂	1.155 (-366.8°F)	3,123.4 (-303°F)	952 (-186°C)	1.861	0.173
Pentachloro-Ethane (47)	C ₂ HCl ₅	1.687	3,549.4	1,082	-	-
Pentalin (47)	C ₂ HCl ₅	1.687	3,549.4	1,082	-	-
Pentane (36)	C ₅ H ₁₂	0.626 (68°F)	3,346.5	1,020	3.905	0.363
n-Pentane (47)	C ₅ H ₁₂	0.557	3,300.5	1,006	4.413	0.41
Perchlorocyclopentadiene (47)	C ₅ Cl ₆	1.718	3,773	1,150	-	-
Perchloro-Ethylene (47)	C ₂ Cl ₄	1.632	3,399	1,036	-	-
Perfluoro-1-Hepten (47)	C ₇ F ₁₄	1.67	1,912.7	583	-	-
Perfluoro-n-Hexane (47)	C ₆ H ₁₄	1.672	1,666.7	508	-	-
Phene (29,40,41)	C ₆ H ₆	0.879	4,284.8	1,306	7.65	0.711
b-Phenyl Acrolein	C ₉ H ₈ O	1.112	5,098.4	1,554	-	-
Phenylamine (41)	C ₆ H ₅ NO ₂	1.022	5,377.3	1,639	39.058	3.63
Phenyl Bromide (46)	C ₆ H ₅ Br	1.522	3,838.6 (68°F)	1,170 (20°C)	7.465	0.693
Phenyl chloride	C ₆ H ₅ Cl	1.106	4,176.5	1,273	7.768	0.722
Phenyl Iodide (46)	C ₆ H ₅ I	1.823	3,654.9 (68°F)	1,114 (20°C)	10.265 (59°F)	0.954 (15°C)
Phenyl Methane (16,52)	C ₇ H ₈	0.867 (68°F)	4,357 (68°F)	1,328 (20°C)	6.929	0.644
3-Phenylpropenal	C ₉ H ₈ O	1.112	5,098.4	1,554	-	-
Phthalaridione	C ₈ H ₄ O ₃	-	3,691 (306°F)	1,125 (152°C)	-	-
Phthalic Acid, Anhydride	C ₈ H ₄ O ₃	-	3,691 (306°F)	1,125 (152°C)	-	-
Phthalicanhydride	C ₈ H ₄ O ₃	-	3,691 (306°F)	1,125 (152°C)	-	-
Pimelicketone	C ₆ H ₁₀ O	0.948	4,668.6	1,423	-	-
Plexiglas, Lucite, Acrylic	-	-	8,698	2,651	-	-
Polyterpene Resin	-	0.77	3,608.4 (374°F)	1,099.8 (190°C)	419,500	39,000
Potassium Bromide (42)	KBr	-	3,835.3 (1652°F)	1,169 (900°C)	7.693 (1652°F)	715CP (900°C)
Potassium Fluoride (42)	KF	-	5,879.3 (1652°F)	1,792 (900°C)	-	-
Potassium Iodide (42)	KI	-	3,231.6 (1652°F)	958 (900°C)	-	-
Potassium Nitrate (48)	KNO ₃	1.859 (665.6°F)	5,709 (666°F)	1,740.1 (352°C)	12.804 (621°F)	1.19 (327°C)
Propane (2,13) (-45°to-130°)	C ₃ H ₈	0.585 (-113°F)	3,290.6 (-46°F)	1,003 (-45°C)	-	-
1,2,3-Propanetriol	C ₃ H ₈ O ₃	1.26	6,246.7	1,904	-	000757
2-Propanol (46)	C ₃ H ₈ O	0.785 (68°F)	3,838.6 (68°F)	1,170 (20°C)	29.245	2.718

2-Propanone	C ₃ H ₆ O	0.791	3,851.7	1,174	4.293	0.399
Propene (17,18,35)	C ₃ H ₆	0.563 (-55.4°F)	3,159.4 (9°F)	963 (-13°C)	-	-
n-Propyl-Acetate (22)	C ₅ H ₁₀ O ₂	-	4,199 (36°F)	1,280 (2°C)	-	-
n-Propyl-Alcohol	C ₃ H ₈ O	0.78 (68°F)	4,009.2 (68°F)	1,222 (20°C)	27.427	2.549
Propylchloride (47)	C ₃ H ₇ Cl	0.892	3,471.1	1,058	4.067	0.378
Propylene (17,18,35)	C ₃ H ₆	0.536 (-55.4°F)	3,159.4 (9°F)	963 (-13°C)	-	-
Pyridne	C ₆ H ₅ N	0.982	4,642.4	1,415	10.673 (68°F)	0.992 (20°C)
Refrigerant11 (3,4)	CCl ₃ F	1.49	2,717.5 (32°F)	828.3 (0°C)	-	-
Refrigerant12(3)	CCl ₂ F ₂	1.516 (-104°F)	2,539.7 (-40°F)	774.1 (-40°C)	-	-
Refrigerant14 (14)	CF ₄	1.75 (-302°F)	2,871.5 (-238°F)	875.24 (-150°C)	-	-
Refrigerant21 (3)	CHCl ₂ F	1.426 (32°F)	2,923.2 (32°F)	891 (0°C)	-	-
Refrigerant22 (3)	CHClF ₂	1.491 (-156.2°F)	2,932.7 (122°F)	893.9 (50°C)	-	-
Refrigerant113 (3)	CCl ₂ F-CClF ₂	1.563	2,571.2 (32°F)	783.7 (0°C)	-	-
Refrigerant114(3)	CClF ₂ -CClF ₂	1.455	2,182.7 (14°F)	665.3 (-10°C)	-	-
Refrigerant115(3)	C ₂ ClF ₅	-	2,153.5 (-58°F)	656.4 (-50°C)	-	-
RefrigerantC318(3)	C ₄ F ₈	1.62 (-68°F)	1,883.2 (41°F)	574 (-10°C)	-	-
Selenium (8)	Se	-	3,517.1 (482°F)	1,072 (250°C)	-	-
Silicone(30cp)	-	0.993	3,248	990	322.8	30
Sodiumfluoride(42)	NaF	0.877	6,830.7 (1832°F)	2,082 (1000°C)	-	-
Sodiumfluoride(48)	NaNO ₃	1.884 (636.8°F)	5,785.1 (637°F)	1,763.3 (336°C)	14.74 (637 °F)	1.37 (336°C)
Sodiumfluoride(48)	NaNO ₂	1.805 (557.6°F)	6,157.5 (558°F)	1,876.8 (292°C)	-	-
Solvesso#3	-	0.877	4,494.8	1,370	-	-
Spiritofwine	C ₂ H ₆ O	0.789	3,960	1,207	15.02	1.397
Sulfur (7,8,10)	S	-	3,861.5 (482°F)	1,177 (250°C)	-	-
SulfueicAcid (1)	H ₂ SO ₄	1.841	4,126	1,257.6	120.081	11.16
Tellurium (7)	Te	-	3,251.3 (842°F)	991 (450°C)	-	-
1,1,2,2-Tetrabromo-Ethane (47)	C ₂ H ₂ Br ₄	2.966	3,369.4	1,027	-	-
1,1,2,2-Tetrachloro-Ethane (67)	C ₂ H ₂ Cl ₄	1.595	3,763.4	1,147	12.438 (59°F)	1.156 (15°C)
Tetrachloroethane (46)	C ₂ H ₂ Cl ₄	1.553 (68°F)	3,838.6 (68°F)	1,170 (20°C)	12.804	1.19
Tetrachloro-Ethene (47)	C ₂ Cl ₄	1.632	3,399	1,036	-	-
Tetrachlor-Methane (33,47)	CCl ₄	1.595 (68°F)	3,038.1	926	6.531	0.607
Tetradecane (46)	C ₁₄ H ₃₀	0.763 (68°F)	4,366.8 (68°F)	1,331 (20°C)	30.773 (68°F)	2.86 (20°C)
Tetraethylene Glycol	C ₈ H ₁₈ O ₅	1.123	5,203.4	1,568	-	-
Tetrafluoro-Methane (14) (Freon14)	CF ₄	1.75 (-302°F)	2,871.5 (-238°F)	875.24 (-150°C)	-	-
Tetrahydro-1,4-isoxazine	C ₄ H ₉ NO	1.000	4,731	1,442	-	-
Toluene (16,52)	C ₇ H ₈	0.867 (68°F)	4,357 (68°F)	1,328 (20°C)	6.929	0.644
o-Toluidine (46)	C ₇ H ₉ N	0.999 (68°F)	5,308.4	1,618	47.279 (68°F)	4.394 (20°C)
p-Toluidine (46)	C ₇ H ₉ N	0.966 (113°F)	4,855.6	1,480	20.053 (122°F)	1.863 (50°C)
Toluol	C ₇ H ₈	0.866	4,291.3	1,308	6.24	0.58
Tribromo-Methane (46,47)	CHBr ₃	2.89 (68°F)	3,011.8	918	7.037	0.645
1,1,1-Trichloro-Ethane (47)	C ₂ H ₃ Cl ₃	1.33	3,231.6	985	9.705 (68°F)	0.902 (20°C)
Trichloro-Ethene (47)	C ₂ HCl ₃	1.464	3,372.7	1,028	-	-
Trichloro-Fluoromethaen (3)(Freon11)	CCl ₃ F	1.49	2,171.5 (32°F)	828.3 (0°C)	-	-
Trichloro-Methane (47)	CHCl ₃	1.489	3,211.9	979	5.918	0.55
1,1,2-Trichloro- 1,2,22-Trifluoro-Etham	CCl ₂ F-CClF ₂	1.563	2,571.2(32°F)	783.7 (0°C)	-	-
Triethyl-Amine (33)	C ₆ H ₁₅ N	0.726	3,684.4	1,123	-	-
Triethyleneglycol	C ₆ H ₁₄ O ₄	1.123	5,275.6	1,608	-	-
1,1,1-Trifluoro-2- Chloro-2-Bromo-Ethane	C ₂ HClBrF ₃	1.869	2,273.6	693	-	-
1,2,2-Trifluorotrichloro- Ethane (Freon113)	CCl ₂ -CClF ₂	1.563	2,571.2 (32°F)	783.7 (0°C)	-	-

d-1,3,3 C10H16O -Trimethylnorcamphor	-	0.947	4,330.7	1,320	2.367	0.22
Trinitrotoluene (43)	C ₇ H ₅ (NO ₂) ₃	1.64	5,282.2 (178°F)	1,610 (81°C)	-	-
Turpentine	-	0.88	4,117.5	1,255	15.064	1.4
Unisis800	-	0.87	4,416	1,346		1.00
Water, Distilled (49,50) Water, Sea	H ₂ O	0.996	4,914.7	1,498	10.76	0.695
WoodAlcohol (40,41)	D ₂ O	-	4,593	1,400	-	-
Xenon (45)		1.025	5,023	1,531	10.76	1.00
m-Xylene (46)	CH ₄ O	0.791 (68°F)	3,530.2	1,076	7.478	0.695
o-Xylene (29,46)	Xe	-	2,067 (-164°F)	630 (-109°C)	-	-
P-xylene (46)	C ₈ H ₁₀	0.868 (59°F)	4,406.2 (68°F)	1,343(20°C)	8.059 (59°F)	0.749 (15°C)
Xylenhexafluoride	C ₈ H ₁₀	0.897 (68°F)	4,368.4	1,331.5	9.716 (68°F)	0.903 (20°C)
Zinc (7)	C ₈ H ₁₀	-	4,376.6 (68°F)	1,334 (20°C)	7.123	0.662
1,1,1-Trifluoro-2-Chloro- 2-Bromo-Ethane	C ₈ H ₄ F ₆	1.37	2,883.9	879	6.595	0.613
1,2,2-Trifluorotrichloro Ethane (Freon113)	Zn	-	10,820.2 (842°F)	3,298 (450°C)	-	-



TEKMATION LLC reserves the right to change the designs and/or materials of its products without notice. The contents of this publication are the property of
TEKMATION and cannot be reproduced by any other party without written permission. All rights reserved. Copyright © 2022 TEKMATON LLC
DOC#TEK/TSP/MNL/220915/1200A/01.4
TEKMATION LLC



www.tek-trol.com

Tek-Trol LLC

796 Tek Drive Crystal Lake, IL 60014,
USA
Sales: +1 847-655-7428

Tek-Trol Solutions BV

Florijnstraat 18, 4879 AH Etten-Leur,
Netherlands
Sales: +31 76-2031908

Tek-Trol Middle East FZE

SAIF Zone, Y1-067, PO BOX No.
21125, Sharjah, UAE
Sales: +971-6526-8344

Support: +1 847-857-6076

Email: tektrol@tek-trol.com

www.tek-trol.com

Tek-Trol is a fully owned subsidiary of TEKMATON LLC. We offer our customers a comprehensive range of products and solutions for process, power and oil & gas industries. Tek-Trol provides process measurement and control products for Flow, Level, Temperature & Pressure Measurement, Control Valves & Analyzer systems. We are present in 15 locations globally and are known for our knowledge, innovative solutions, reliable products and global presence.

Flow | Level | Temperature | Pressure | Valves | Analyzers | Accessories | TekValSys