

Tek-Sub 4800D



Wastewater Submersible Level Transmitter



Quick Start Guide

1. Before You Begin

This guide provides basic guidelines to assist you in quickly getting started.

-  Installation of the device must be carried out by trained and qualified specialists authorized to perform such work by the system owner. The specialist must have read and understood these operating instructions and must follow them.
-  Handle the instrument with care, both in packed and unpacked condition.
-  All permissible media are specified in the data sheet. In addition, it has to be ensured that this media is compatible with the wetted parts of Tek-Sub 4800D.

2. Unpack

Tek-Sub 4800D Wastewater Submersible Level Transmitter (1 unit)

3. Dimensional Drawing

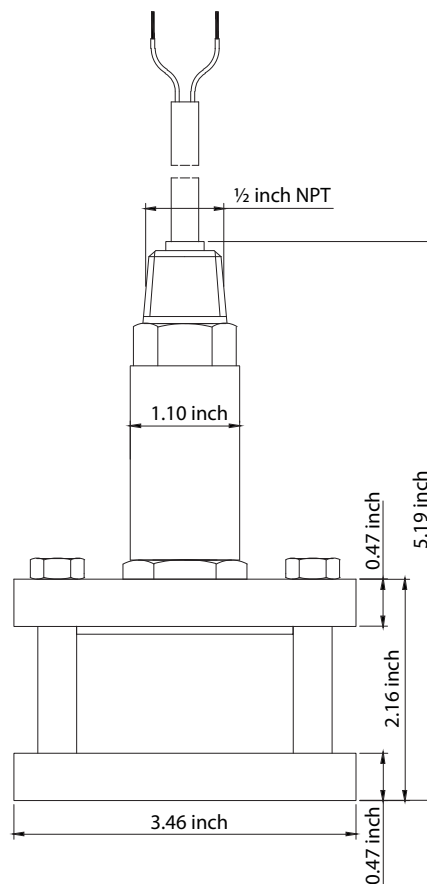
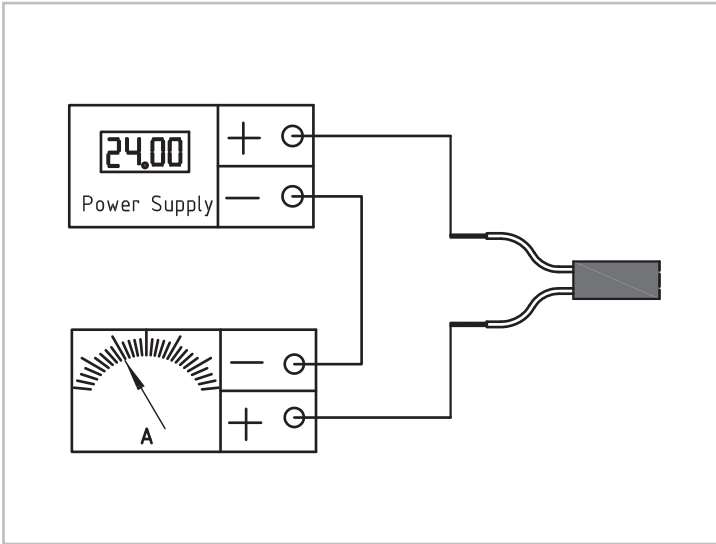

Fig. 1. Dimensional Drawing

4. Power Supply Wirings

Wiring Diagram

4~20mA/4~20mA+HART (2 wire)
Power+: Red
Signal+: Green



0~5VDC/1~5VDC/0.5~4.5V/0~10VDC (3 wire)
Power+: Red
Gnd: Green
Signal+: Yellow

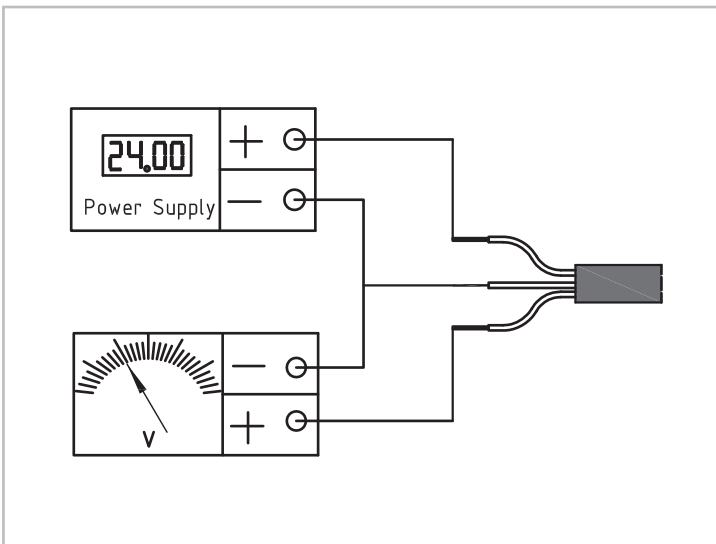

RS485 (4 wire)
Power+: Red
Gnd: Green
485 A: Yellow
485 B: Blue

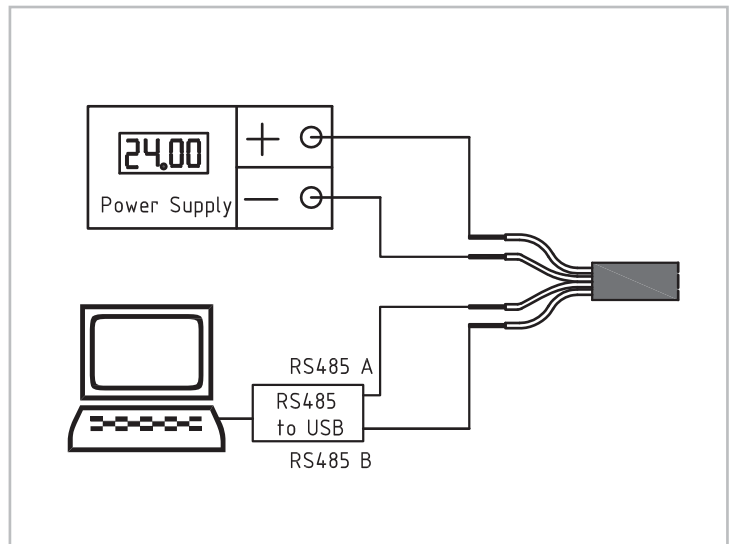

Quick Start Guide

5. Installation

Installation Method

- The installation direction of the transmitter is vertically down.
- In a flowing liquid application, the surface of the transmitter should be parallel with the direction of the liquid flow.

Installation in Static Liquid

- Fig. 2 shows the installation method used in case of static liquid.
- While pumping the liquid, the transmitter should be uninstalled from the tank or it should be protected by a stilling well as shown in Fig. 3.

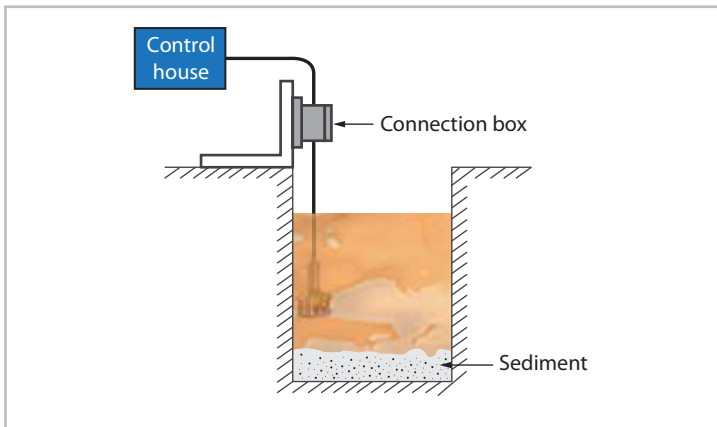

Fig. 2. Installation in static liquid

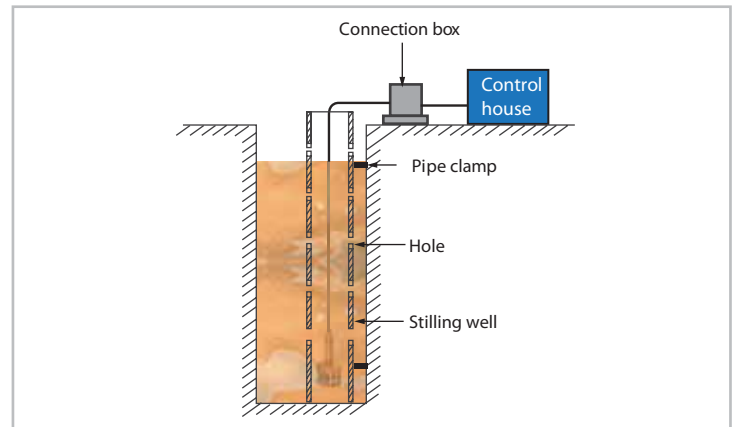

Fig. 3. Stilling well protection

Installation in Flowing Liquid

- **Method One: Use a stilling well in the water channel**

Fig. 4 shows the installation method used in case of flowing liquid, for example, reservoir area or river channel. Use of a stilling well will dampen disruptions and provide a steady level for an accurate measurement.

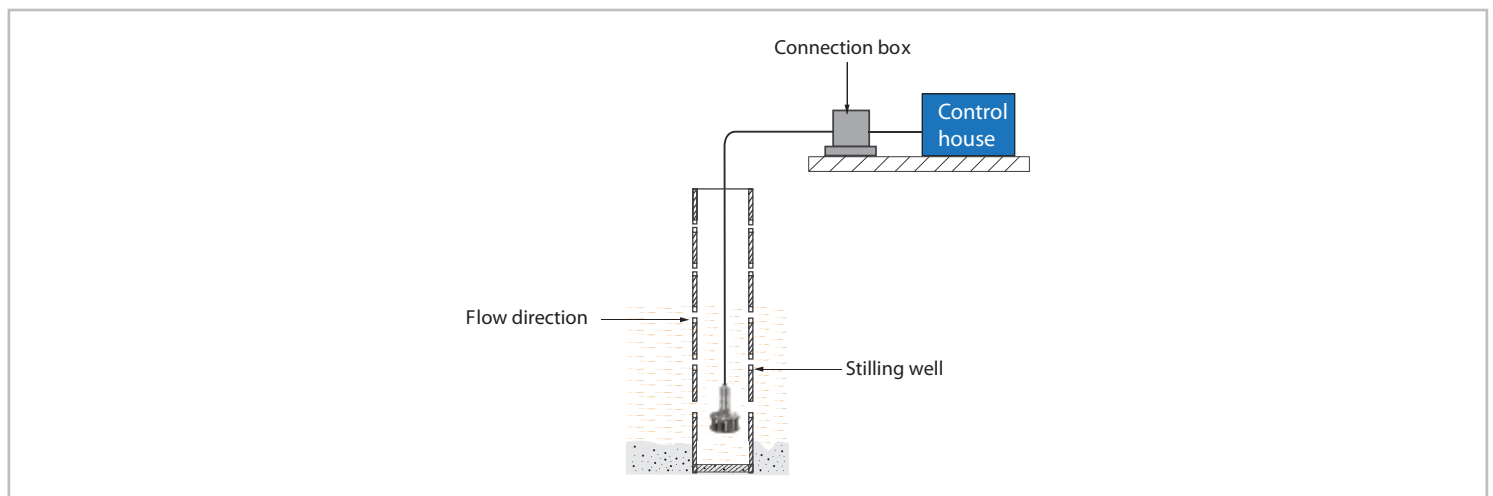

Fig. 4. Stilling well protection

- **Method Two:** Fig. 5 shows the superficial burying is done in the sand and stone channel.

This method not only eliminates pressure of the water flow and wave influence, but also filters the sand and mud particles.

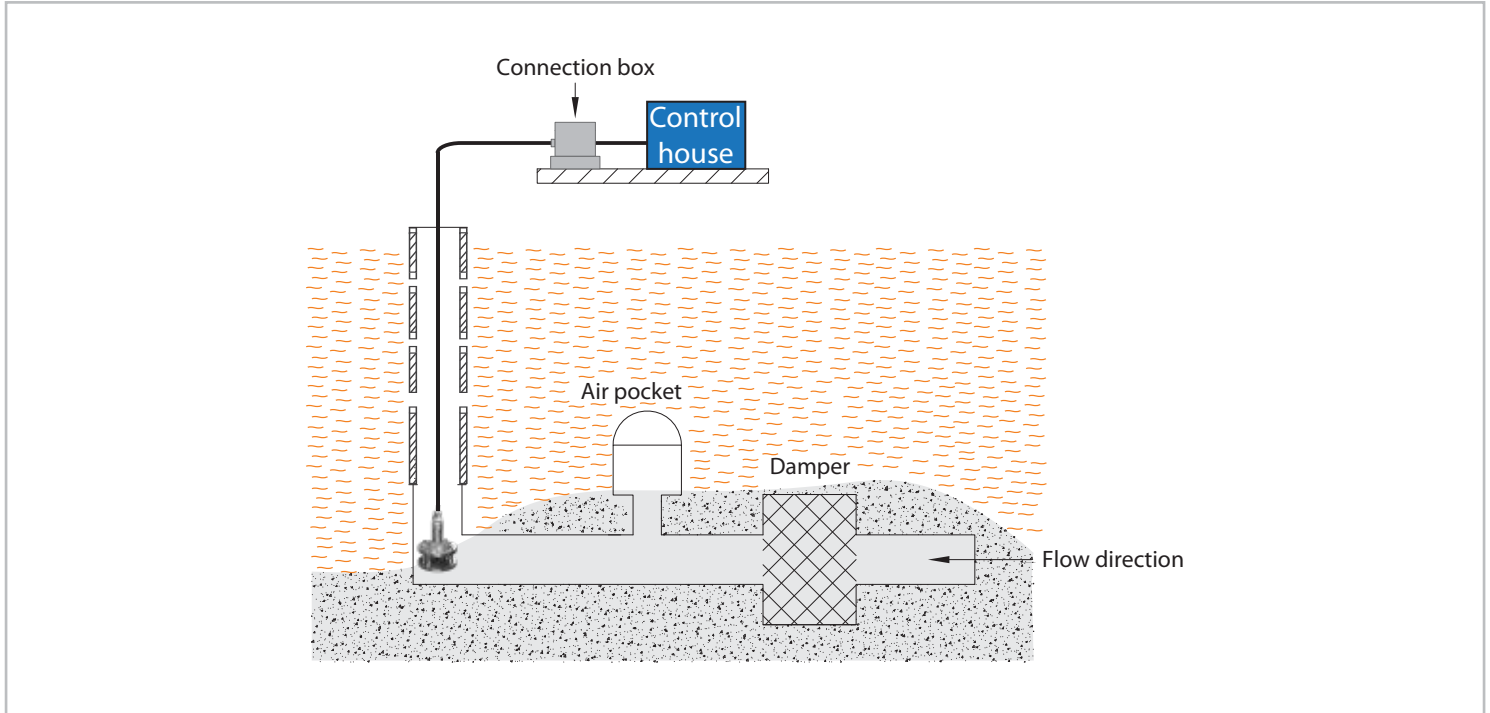

Fig. 5. Superficial burying

6. Maintenance

The Tek-Sub 4800D Wastewater Submersible Level Transmitter does not require regular maintenance, however the following points must be observed for better operation and reliability.

- Make sure that the wire connection is reliable.
- Make sure that the cable is not damaged.
- Clean the protection cap and diaphragm space regularly.
- Do not pull the cables violently or poke the diaphragm with metal objects.

Quick Start Guide

7. Error Identification

Table 1 shows the troubleshooting techniques for most common operating problems.

Symptom	Corrective Action
No Output or Low Output	Check the polarity of the terminals. Check for intermittent shorts, open circuits and multiple grounds.
	Check that adequate voltage is supplied to the transmitter. The transmitter requires 12 to 36VDC.
	Verify sensor positioning and consider sensor cleaning.
High Output	Check for dirty or defective terminals and interconnecting pins.
	Check that adequate voltage is supplied to the transmitter. The transmitter requires 12 to 36VDC.
	Check the sensor limits to ensure that input to the sensor is within the range.
Erratic Output	Check that adequate voltage is supplied to the transmitter. The transmitter requires 12 to 36VDC.
	Check the polarity of the terminals. Check for intermittent shorts, open circuits and multiple grounds.
	Verify sensor positioning and consider sensor cleaning.

Table 1: Troubleshooting

NOTE: If error persists, contact Tek-Trol representative immediately.

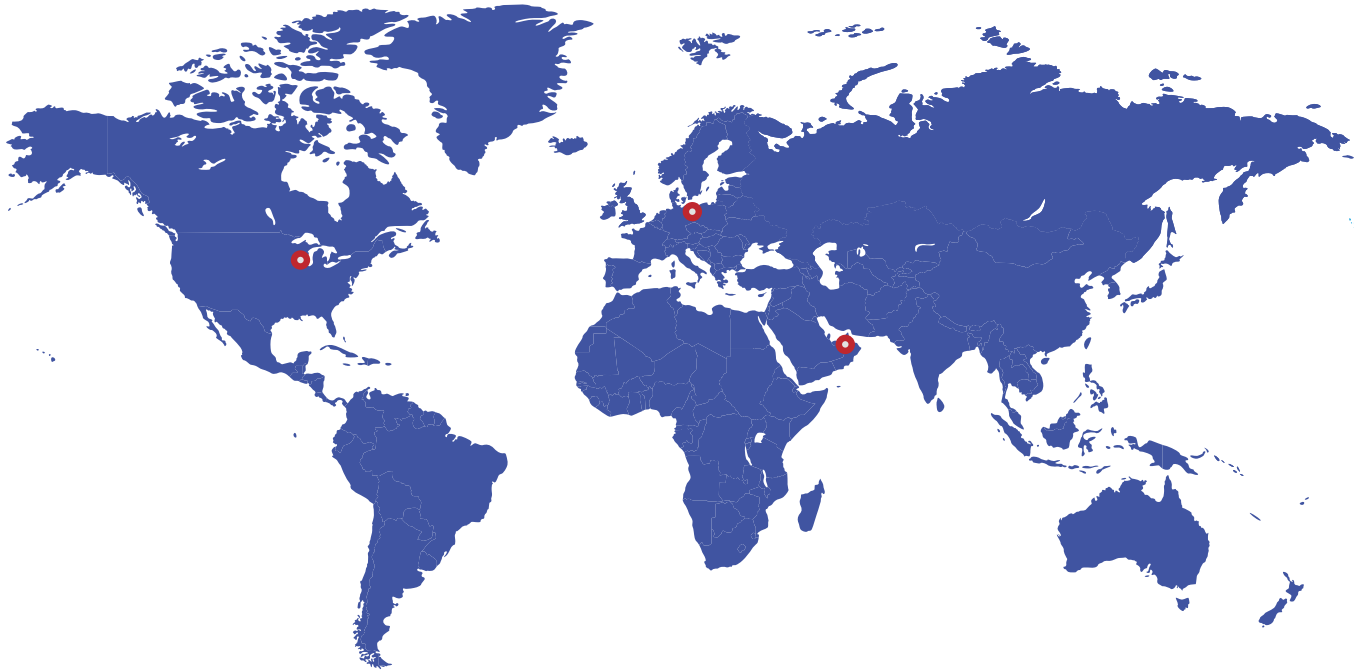

Tek-Trol LLC

796 Tek Drive Crystal Lake, IL
60014, USA
Sales: +1 847-655-7428

Tek-Trol Solutions BV

Florijnstraat 18, 4879 AH
Etten-Leur, Netherlands
Sales: +31 76-2031908

Tek-Trol Middle East FZE

SAIF Zone, Y1-067, PO BOX No.
21125, Sharjah, UAE
Sales: +971-6526-8344

Support: +1 847-857-6076

Email: tektrol@tek-trol.com

www.tek-trol.com
