

## SERIES 355N (T) - 365N (L) DIRECT MOUNT 3 WAY BALL VALVE



Three way brass ball valve with ISO 5211 pad for actuator, standard port, from 1/4" to 3".

- Four seat design for sealing between pressurized ports.
- Pressure rating 400 WOG - 100 WSP.
- Model 355N (90° and 180° flow path).
- Model 365N (90° with off position).
- Temperature range -4° F to +366 °F.
- Blow out proof stem, chrome plated brass ball.
- P.T.F.E seats with O-ring backing for low operating torque.
- P.T.F.E seats and double O-ring stem packing.
- 100% electronically tested in the open and closed position at 80 psi.
- Not to be used for drinking water.

355N: LEVER HANDLE - size 1/4" to 3", "T" flow pattern.

365N: LEVER HANDLE - size 1/4" to 3", "L" flow pattern.



MEETS THE DESIGN CRITERIA OF MSS\_SP\_110.

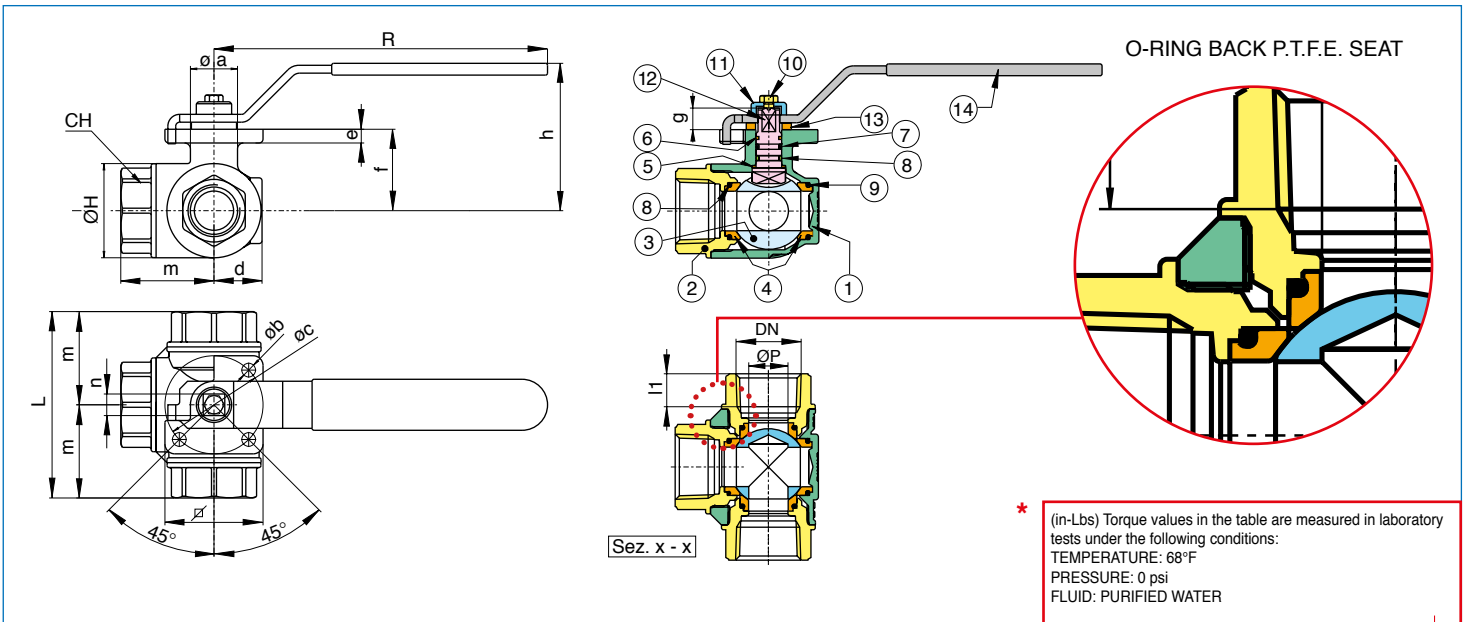

N POS	PART NAME	MATERIAL	N PCS	SIZE	ØP	ØH	l1	L	m	CH	R	h	Øa	Øb	Øc	d	e	f	g	∠	n	CV 355N	CV 365N	psi	Lbs	* in-Lbs
1	BODY	BRASS CW 617 NUNI EN 12165	1	1/4"	0.39	1.34	0.39	2.64	1.32	0.86	4.72	2.44	0.87	0.23	1.42 (ISO F03)	0.77	0.20	1.20	0.35	1.49	0.35	3.26	3.50	400	1.22	53.10
2	END CONNECTION	BRASS CW 617 NUNI EN 12165	3	3/8"	0.43	1.34	0.40	2.64	1.32	0.86	4.72	2.44	0.87	0.23	1.42 (ISO F03)	0.77	0.20	1.20	0.35	1.49	0.35	3.50	4.08	400	1.16	53.10
3	BALL	BRASS CW 617 NUNI EN 12165	1	1/2"	0.43	1.34	0.53	2.87	1.44	1.06	4.72	2.44	0.87	0.23	1.42 (ISO F03)	0.77	0.20	1.20	0.35	1.49	0.35	4.20	5.02	400	1.21	53.10
4	BALL SEAT	P.T.F.E	4	3/4"	0.59	1.53	0.55	3.19	1.60	1.25	4.72	2.52	0.87	0.23	1.42 (ISO F03)	0.87	0.20	1.29	0.35	1.49	0.35	7.00	7.70	400	1.44	53.10
5	THRUST WASHER	P.T.F.E	1	1"	0.79	1.89	0.66	3.74	1.87	1.61	6.69	2.95	0.94	0.27	1.97 (ISO F05)	1.00	0.28	1.63	0.43	1.97	0.43	12.83	14.24	400	2.64	150.46
6	STEM SEAL	P.T.F.E	1	1 1/4"	0.98	2.36	0.68	4.39	2.20	1.96	6.69	3.17	0.94	0.27	1.97 (ISO F05)	1.22	0.28	1.85	0.43	1.97	0.43	18.67	19.72	400	4.15	150.46
7	O-RING	EPDM	1	1 1/2"	1.26	2.83	0.68	4.86	2.43	2.16	6.69	3.66	1.26	0.27	1.97 (ISO F05)	1.79	0.28	2.34	0.43	1.97	0.43	29.75	30.69	400	6.02	150.46
8	O-RING	FKM (Viton®)	1	2"	1.57	3.38	0.70	5.73	2.87	2.75	9.05	4.43	1.46	0.35	2.76 (ISO F07)	1.75	0.32	2.90	0.59	2.75	0.55	43.76	48.58	400	9.08	274.37
9	O-RINGS BODY	FKM (Viton®)	4	2 1/2"	1.95	4.37	0.93	6.93	3.47	3.34	9.05	4.86	1.46	0.35	2.76 (ISO F07)	2.20	0.32	3.35	0.59	2.75	0.55	70.00	72.35	400	16.33	380.58
10	SCREW	STEEL 6/S	1	3"	1.95	4.45	1.01	7.08	3.54	4.13	9.05	4.86	1.46	0.35	2.76 (ISO F07)	2.20	0.32	3.35	0.59	2.75	0.55	70.00	72.35	400	19.55	380.58
11	BUSH	BRASS CW 614 NUNI EN 12164	1																							
12	STEM	BRASS CW 614 NUNI EN 12164	1																							
13	WASHER	NYLON	1																							
14	HANDLE	Fe DD 11 UNI EN 10111	1																							

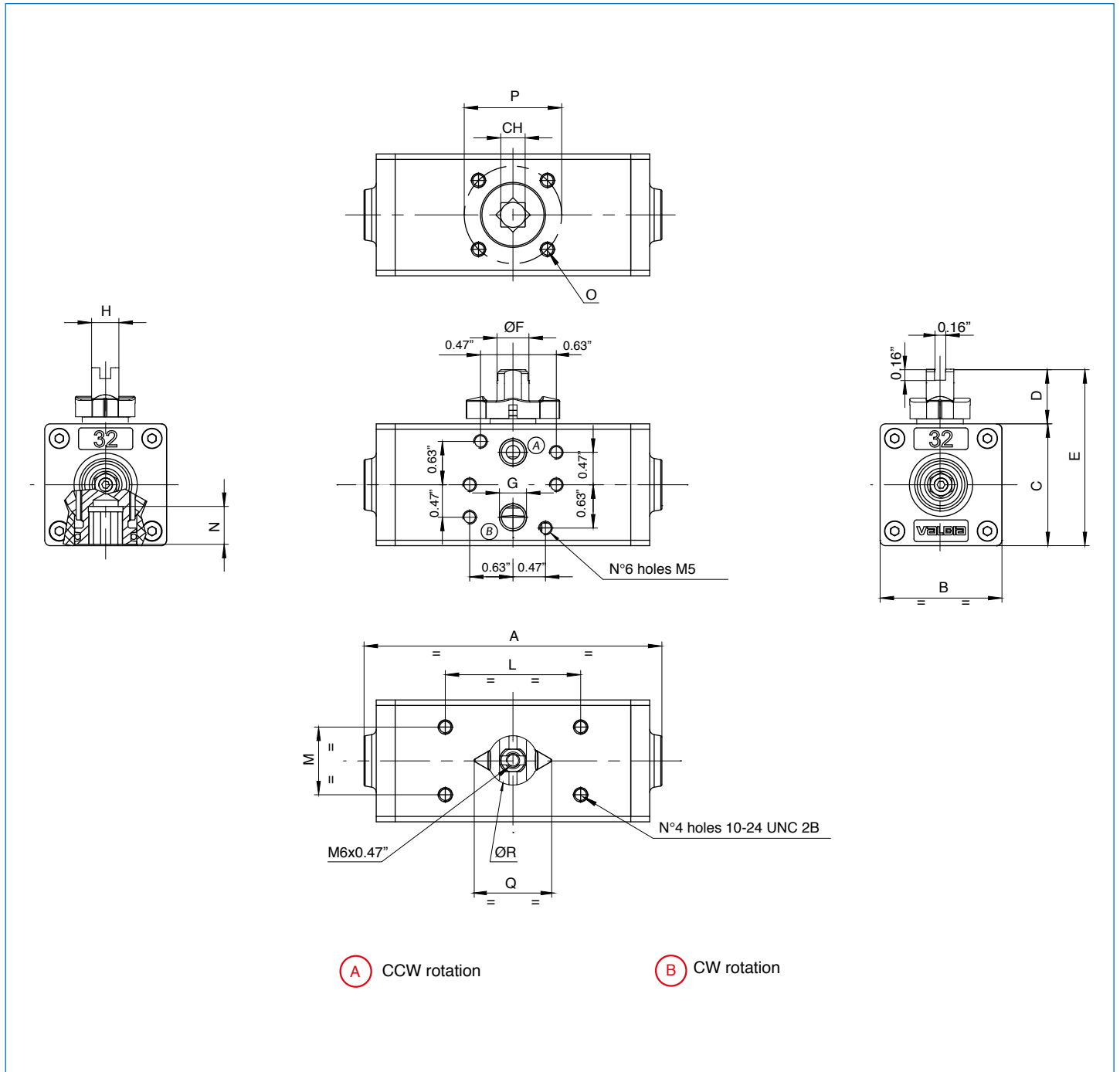

MOD.	DRILLING ISO 5211	CH	A	B	C	D	E	ØF	G NPT	H	L	M	N	O	P	Q	øR
32	F03	0.35	4.33	1.77	1.77	0.79	2.56	0.46	1/8"	0.39	1.97	0.98	0.47	10-24 UNC 2Bx0.30	1.42	1.36	0.87

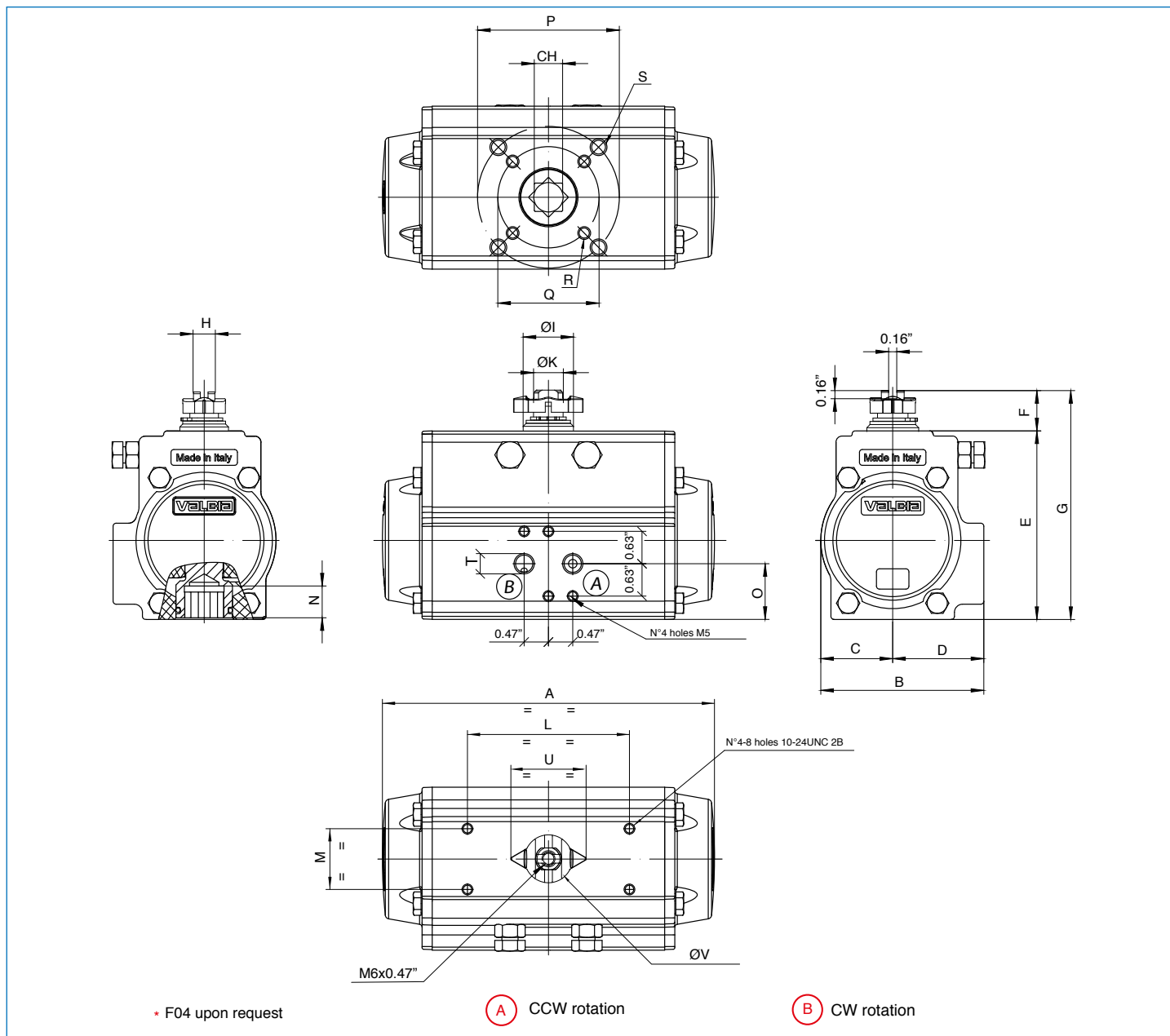

MOD.	DRILLING ISO 5211	CH	A	B	C	D	E	F	G	H	ØI	ØK	L	M	N	O	P	Q	R	S	T NPT	U	øV
52	F03-F05 *	0.43	5.55	2.80	1.18	1.61	3.21	0.79	4.00	0.39	0.83	0.47	3.15	1.18	0.47	1.04	1.97	1.42	10-24 UNC 2Bx0.29"	1/4-20 UNC 2Bx0.35"	1/8"	1.36	0.87
63	F05 - F07	0.55	6.46	3.17	1.40	1.77	3.66	0.79	4.45	0.43	0.98	0.59	3.15	1.18	0.63	1.08	2.76	1.97	1/4-20 UNC 2Bx0.31"	5/16-18 UNC 2Bx0.47"	1/8"	1.36	0.87
75	F05 - F07	0.67	8.27	3.72	1.65	2.07	4.37	0.79	5.16	0.51	1.14	0.75	3.15	1.18	0.75	1.38	2.76	1.97	1/4-20 UNC 2Bx0.31"	5/16-18 UNC 2Bx0.47"	1/8"	1.65	1.14
85	F05 - F07	0.67	9.47	4.17	1.87	2.30	4.92	0.79	5.71	0.59	1.38	0.86	3.15	1.18	0.75	1.65	2.76	1.97	1/4-20 UNC 2Bx0.31"	5/16-18 UNC 2Bx0.47"	1/8"	1.65	1.14
100	F07 - F10	0.67	10.83	4.84	2.17	2.68	5.43	0.79	6.21	0.59	1.38	0.86	3.15	1.18	0.81	1.97	4.02	2.76	5/16-18 UNC 2Bx0.31"	3/8-16 UNC 2Bx0.55"	1/4"	1.65	1.14
115	F07 - F10	0.87	13.11	5.39	2.52	2.87	6.39	1.18	7.57	0.87	1.93	1.26	3.15/5.12	1.18	0.94	1.97	4.02	2.76	5/16-18 UNC 2Bx0.47"	3/8-16 UNC 2Bx0.59"	1/4"	2.52	1.73
125	F07 - F10	0.87	14.65	5.83	2.68	3.15	6.87	1.18	8.05	0.87	1.93	1.26	3.15/5.12	1.18	0.94	2.40	4.02	2.76	5/16-18 UNC 2Bx0.47"	3/8-16 UNC 2Bx0.59"	1/4"	2.52	1.73
140	F10 - F12	1.06	17.13	6.46	3.01	3.44	7.76	1.18	8.94	0.94	1.93	1.38	3.15/5.12	1.18	1.14	2.80	4.92	4.02	3/8-16 UNC 2Bx0.59"	1/2-13 UNC 2Bx0.71"	1/4"	2.52	1.73
160	F10 - F12	1.06	19.69	7.32	3.43	3.90	8.70	1.18	9.88	1.18	2.24	1.57	3.15/5.12	1.18	1.26	3.15	4.92	4.02	3/8-16 UNC 2Bx0.55"	1/2-13 UNC 2Bx0.67"	1/4"	3.17	2.36
180	F10 - F14	1.42	19.41	8.38	3.86	4.53	9.96	1.18	11.14	1.42	2.44	1.77	3.15/5.12	1.18	1.69	3.90	5.51	4.02	3/8-16 UNC 2Bx0.59"	5/8-11 UNC 2Bx0.98"	1/4"	3.17	2.36
200	F14	1.42	22.76	8.54	4.25	4.29	10.94	1.18	12.13	1.42	2.64	1.97	3.15/5.12	1.18	1.46	3.07	5.51	/	/	5/8-11 UNC 2Bx0.94"	1/4"	3.17	2.36
230	F16	* 1.81	27.17	9.78	4.88	4.90	12.80	1.18	13.98	1.42	2.64	1.97	3.15/5.12	1.18	1.97	3.62	6.50	/	/	3/4-10 UNC 2Bx1.14"	1/4"	3.17	2.36

\*\* Only square connection at 45°.

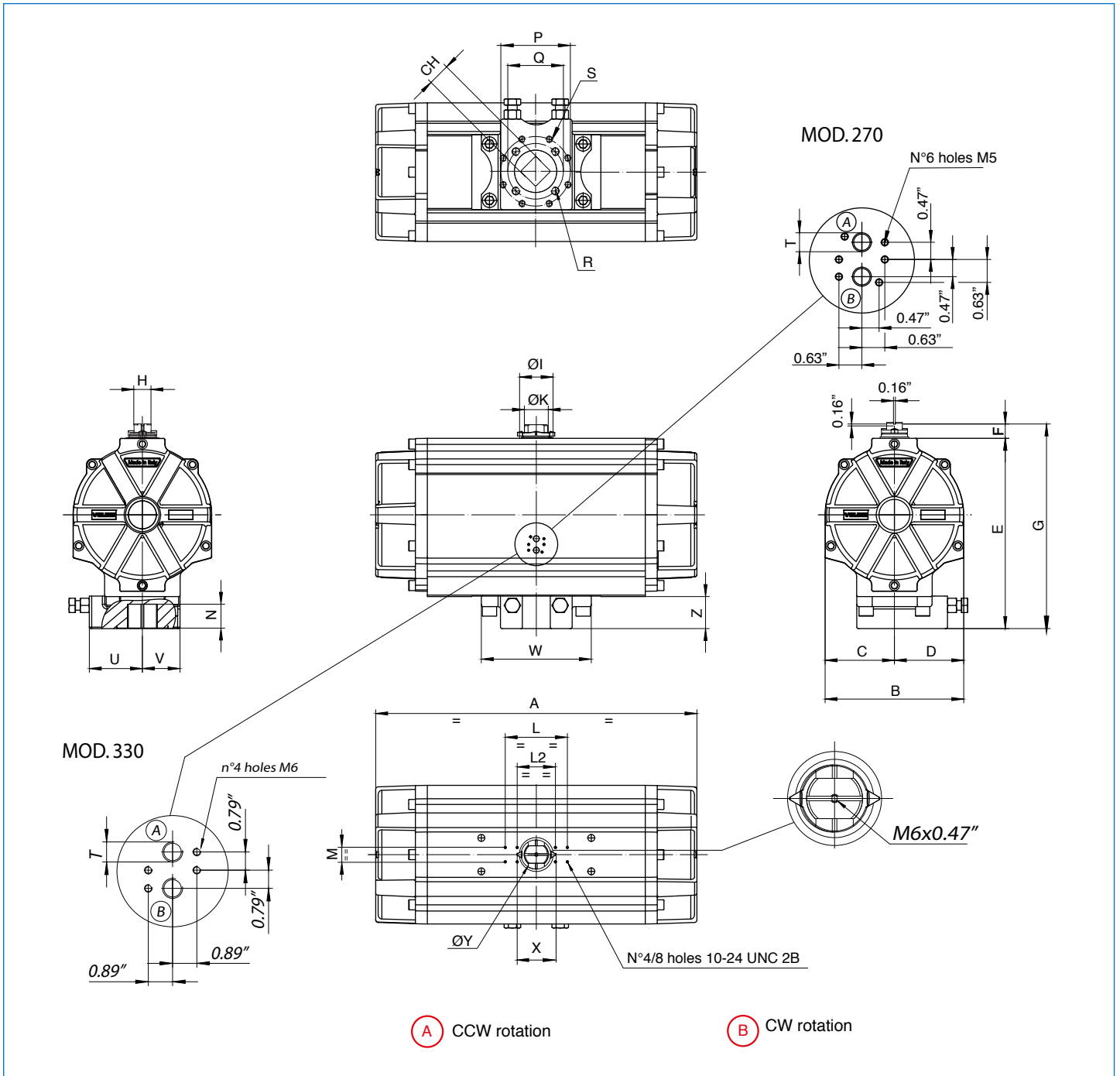

MOD.	DRILLING ISO 5211	CH	A	B	C	D	E	F	G	H	ØI	ØK	L	L2	M	N	P	Q	R	S	T NPT	U	V	W	Z	X	ØY
270	F16	**	26.46	11.42	5.71	5.71	15.71	1.18	16.89	1.42	2.76	1.97	5.12	3.15	1.18	1.97	/	6.50	3/4-10 UNC 2Bx1.18"	/	1/4"	4.37	3.11	9.06	2.68	3.17	2.36
330	F16-F25	**	34.69	15.83	7.91	7.91	19.88	1.97	21.85	1.42	4.29	1.97	5.12	/	1.18	2.44	10	6.50	3/4-10 UNC 2Bx1.18"	5/8-11 UNC 2Bx1.02"	1/2"	5.08	5.32	11.69	3.74	3.17	2.36

\*\* Only square connection at 45°.

## DOUBLE ACTING ACTUATOR

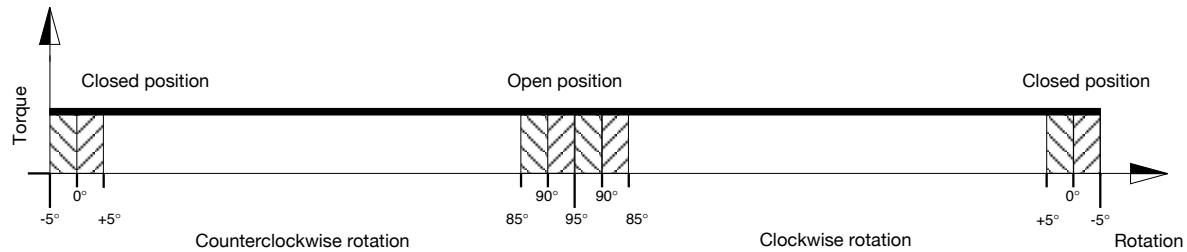
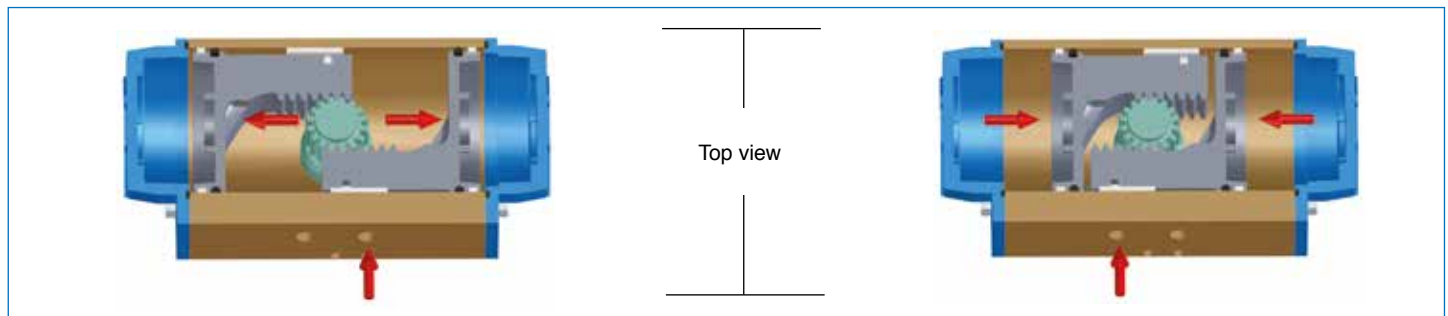

With reference to the above diagram it can be noted that the torque of a double acting actuator remains constant through-out the complete action.

The user can decide on which model to choose according to the own specific requirements, using the following guidelines:

1. Define the maximum torque of the valve to automate.
2. To obtain a safety factor increase the torque value chosen by 25% - 50% (subject to the type of valve and working conditions).
3. Once the torque value suggested is obtained consult the torque chart and in relation to the corresponding air pressure find a torque value exact to or exceeding the one obtained.
4. Once the torque value is determined move horizontally to the column "model" to find the actuator model required.

TYPE	AIR SUPPLY PRESSURE (psi)							
	40	50	60	70	80	90	100	115
	TORQUE OUTPUT DOUBLE ACTING ACTUATORS (in-Lbs)							
DA 32	34	43	55	64	71	82	87	101
DA 52 *	88	112	133	158	178	201	227	263
DA 63 *	152	193	238	282	320	361	405	469
DA 75 *	283	356	435	513	586	659	736	851
DA 85 *	406	514	628	744	853	960	1072	1237
DA 100 *	645	814	989	1163	1333	1505	1681	1939
DA 115	1065	1344	1640	1932	2212	2488	2779	3211
DA 125	1402	1771	2153	2539	2905	3274	3650	4220
DA 140	2003	2504	3005	3506	4006	4509	5009	5764
DA 160	2804	3501	4196	4899	5596	6292	6987	8045
DA 180	3860	4825	5790	6746	7711	8661	9627	11081
DA 200	5198	6494	7796	9089	10393	11670	12972	14924
DA 230	8589	10738	12880	15031	17180	19289	21440	24671
DA 270	12625	15777	18935	22093	25246	28361	31511	36269
DA 330	22464	28083	33702	39321	44939	50476	56086	64555

\* Valid also for stainless steel actuator