

TKD SERIES 3-WAY BALL VALVES - TRUE UNION

The TKD offers a host of advanced features that set it apart from other multi-port valves. The patented seat stop carrier allows for in-line micro-adjustment of the ball seating, and features o-ring cushioning to minimize wear and prevent seizing. Integral mounting flange and bracketing allows for direct actuation and simple support, while a locking handle can prevent improper positioning. The TKD is available in PVC with PTFE seats and either EPDM or Viton® seals. Other materials are available upon request.

Pressure: 232 psi at 73°F

Sizes: 1/2" – 2"



End Connection	Size inches	EPDM Product Code	Viton® Product Code
----------------	-------------	-------------------	---------------------

PVC, w/ PTFE Seats , L-Port

S/T	1/2	253844	253856
S/T	3/4	253845	253857
S/T	1	253846	253858
S/T	1-1/4	253847	253859
S/T	1-1/2	253848	253860
S/T	2	253849	253861

PVC, w/ PTFE Seats , T-Port

S/T	1/2	253850	253862
S/T	3/4	253851	253863
S/T	1	253852	253864
S/T	1-1/4	253853	253865
S/T	1-1/2	253854	253866
S/T	2	253855	253867

Ball valves are generally used for on/off service, but can range from simple molded-in-place construction to high-end industrial designs with many features and benefits. Multi-port ball valves allow for mixing, diverting, and bypassing flow. Extensive material options provide for complete chemical compatibility in highly corrosive processes. Many ball valves feature full port flow, blocking true union ends, and compact ergonomic designs allowing for simple installation and maintenance.

PHYSICAL PROPERTIES

PVC (POLYVINYL CHLORIDE) CPVC (CHLORINATED POLYVINYL CHLORIDE)

PROPERTIES	MATERIALS			STANDARDS
	PVC	CPVC (STANDARD)	CORZAN CPVC (HIGH IMPACT)	
Cell classification	12454	23447	24448	ASTM D1784
Specific gravity	1.42	1.50	1.51	ASTM D792
Tensile strength, psi at 73°F	7,000	7,500	7,320	ASTM D638
Modulus of elasticity tensile, psi at 73°F	400,000	380,000	423,000	ASTM D638
Flexural strength, psi	14,500	11,400	13,200	ASTM D790
Izod impact, ft.lbs./in. at 73°F, notched	0.65	2.0	10.0	ASTM D256
Compressive strength, psi	9,000	10,100	10,100	ASTM D695
Poisson's ratio	0.38	0.33	0.33	
Working stress, psi at 73°F	2,000	2,000	2,000	
Coefficient of thermal expansion in./in./°F (x 10 ⁻⁵)	3.0	3.8	3.4	ASTM D696
Linear expansion, in./10°F per 100' of pipe	0.36	0.44 - 0.46	0.41	
Maximum operating temperature under pressure	140°F (60°C)	200°F (93°C)	200°F (93°C)	
Deflection temperature under load, °F at 66 psi	173	n/a	n/a	ASTM D648
Deflection temperature under load, °F at 264 psi	160	212	239	ASTM D648
Thermal conductivity, BTU.in./hr.ft ² .°F	1.2	0.95	0.95	ASTM C177
Burning rate	Self extinguish	Self extinguish	Self extinguish	ASTM D635
Burning class	V-0	V-0	V-0	UL-94
Flash ignition, °F	730	900	900	
Limited oxygen index (%)	43	60	60	ASTM D2863-70
Water absorption, %, (24 hrs. at 73°F)	0.05	0.03	0.03	ASTM D570

* The properties listed in this table represent general material properties and should be used as a guideline only.

PVC PIPE PRESSURE RATINGS

Sizes		IPEX schedule 40 PVC			IPEX Schedule 80 PVC		
Diameter	O.D.	Wall Thickness	I.D.	*Max. Pressure 73°F	Wall Thickness	I.D.	*Max. Pressure 73°F
(in.)	(in.)	(in.)	(in.)	(psi)	(in.)	(in.)	(psi)
1/4	.540	–	–	–	.119	.302	1,130
3/8	.675	–	–	–	.126	.423	920
1/2	.840	.109	.602	600	.147	.526	850
3/4	1.050	.113	.804	480	.154	.722	690
1	1.315	.133	1.029	450	.179	.936	630
1-1/4	1.660	.141	1.360	370	.191	1.255	520
1-1/2	1.900	.145	1.590	330	.200	1.476	470
2	2.375	.154	2.047	280	.218	1.913	400
2-1/2	2.875	.203	2.445	300	.276	2.290	420
3	3.500	.216	3.042	260	.300	2.864	370
4	4.500	.237	3.998	220	.337	3.786	320
6	6.625	.280	6.031	180	.432	5.709	280
8	8.625	.322	7.941	160	.500	7.565	250
10	10.750	.365	9.976	140	.593	9.493	230
12	12.750	.406	11.888	130	.687	11.294	230
14	14.000	.438	13.072	130	.750	12.412	220
16	16.000	.500	14.936	130	.843	14.224	220
18	18.000	.562	16.809	130	.937	16.014	220
20	20.000	.593	18.743	120	1.031	17.814	220
24	24.000	.687	22.544	120	1.218	21.418	210

CPVC PIPE PRESSURE RATINGS

Sizes		IPEX schedule 40 CPVC			IPEX Schedule 80 CPVC		
Diameter	O.D.	Wall Thickness	I.D.	*Max. Pressure 73°F	Wall Thickness	I.D.	*Max. Pressure 73°F
(in.)	(in.)	(in.)	(in.)	(psi)	(in.)	(in.)	(psi)
1/2	.840	.109	.602	600	.147	.526	850
3/4	1.050	.113	.804	480	.154	.722	690
1	1.315	.133	1.029	450	.179	.936	630
1-1/4	1.660	.141	1.360	370	.191	1.255	520
1-1/2	1.900	.145	1.590	330	.200	1.476	470
2	2.375	.154	2.047	280	.218	1.913	400
2-1/2	2.875	.203	2.445	300	.276	2.290	420
3	3.500	.216	3.042	260	.300	2.864	370
4	4.500	.237	3.998	220	.337	3.786	320
6	6.625	.280	6.031	180	.432	5.709	280
8	8.625	.322	7.941	160	.500	7.565	250
10	10.750	.365	9.976	140	.593	9.493	230
12	12.750	.406	11.888	130	.687	11.294	230
14	14.000	.438	13.072	130	.750	12.412	220
16	16.000	.500	14.936	130	.843	14.224	220

DOUBLE ACTING ACTUATOR

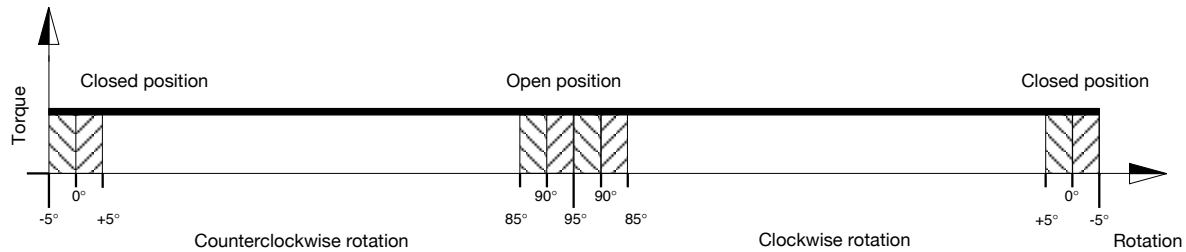
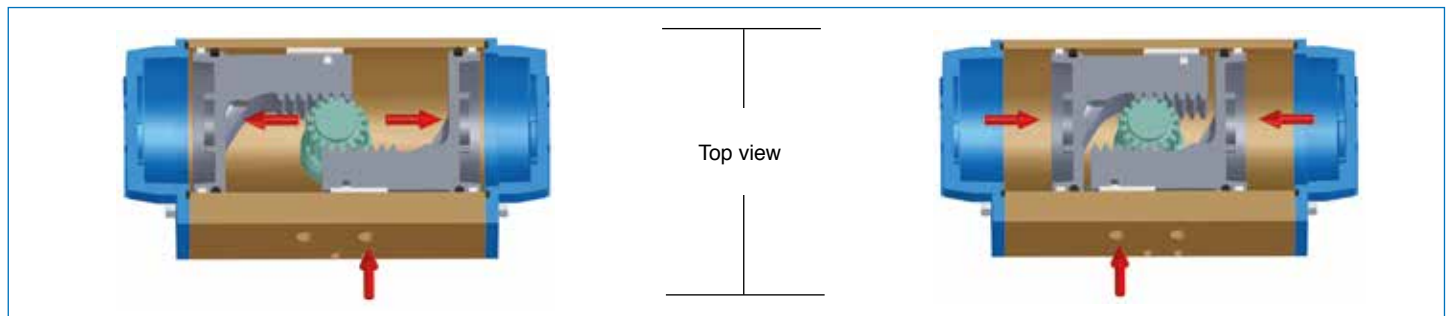

With reference to the above diagram it can be noted that the torque of a double acting actuator remains constant through-out the complete action.

The user can decide on which model to choose according to the own specific requirements, using the following guidelines:

1. Define the maximum torque of the valve to automate.
2. To obtain a safety factor increase the torque value chosen by 25% - 50% (subject to the type of valve and working conditions).
3. Once the torque value suggested is obtained consult the torque chart and in relation to the corresponding air pressure find a torque value exact to or exceeding the one obtained.
4. Once the torque value is determined move horizontally to the column "model" to find the actuator model required.

TYPE	AIR SUPPLY PRESSURE (psi)							
	40	50	60	70	80	90	100	115
	TORQUE OUTPUT DOUBLE ACTING ACTUATORS (in-Lbs)							
DA 32	34	43	55	64	71	82	87	101
DA 52 *	88	112	133	158	178	201	227	263
DA 63 *	152	193	238	282	320	361	405	469
DA 75 *	283	356	435	513	586	659	736	851
DA 85 *	406	514	628	744	853	960	1072	1237
DA 100 *	645	814	989	1163	1333	1505	1681	1939
DA 115	1065	1344	1640	1932	2212	2488	2779	3211
DA 125	1402	1771	2153	2539	2905	3274	3650	4220
DA 140	2003	2504	3005	3506	4006	4509	5009	5764
DA 160	2804	3501	4196	4899	5596	6292	6987	8045
DA 180	3860	4825	5790	6746	7711	8661	9627	11081
DA 200	5198	6494	7796	9089	10393	11670	12972	14924
DA 230	8589	10738	12880	15031	17180	19289	21440	24671
DA 270	12625	15777	18935	22093	25246	28361	31511	36269
DA 330	22464	28083	33702	39321	44939	50476	56086	64555

* Valid also for stainless steel actuator

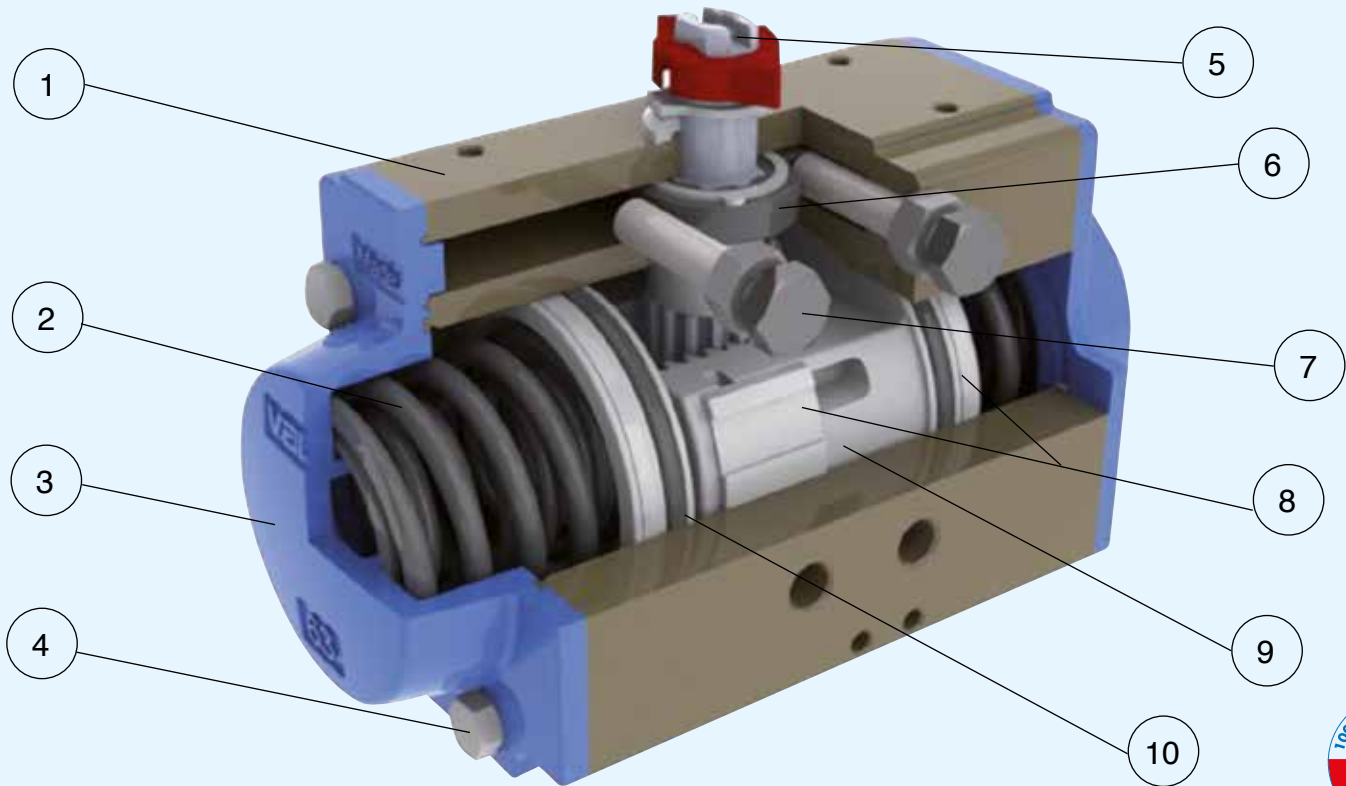

1 BODY MANUFACTURED FROM EXTRUDED ALUMINUM UNI 6060:

- Hard-coat anodized as standard finish 45-50 (micron).
- Good wear resistance.
- High corrosion resistance.
- Special finishes nichel-plating or P.T.F.E coated upon request.
- Bore finished to high standard to ensure low friction and long life.

2 CONCENTRING SPRING SETS

- Standard coating painted.
- High resistance and reliability.
- Spring sets to suit different air pressure/torque requirements.
- Long securing screws to allow safe dismantling for maintenance.
- Same body dimensions for DA/SR versions.

3 DIE CAST ALUMINIUM END CAPS:

- Standard polyester powder coated
- Upon request nickel - plated and or P.T.F.E coated for corrosive environments.

4 ASSEMBLING SCREW:

- Stainless steel as standard.

EXTERNAL CONNECTION:

- Top of pinion according to Namur norm.
- Solenoid valve connection according to Namur norm.
- Bottom of pinion according to ISO 5211-DIN 3337.

NOMINAL VALUES:

- Pressure rating max 8 bar.
- Temperature range: standard (-4°F;+185°F), high (-4°F;+302°F), low (-40°F;+185°F).
- Pre lubricated for life of actuator on assembly.
- Fully tested on manufacture 100%.

MOUNTING VARIATIONS

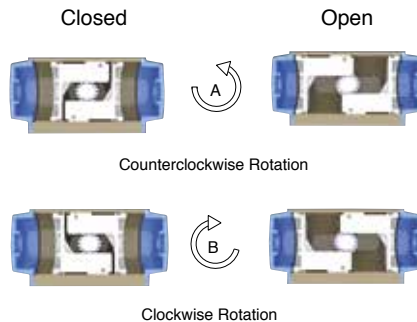

View from the top of the pinion

ANTI-BLOWOUT SYSTEM

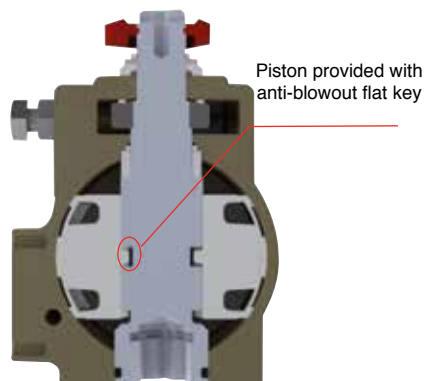

5 PINION MADE IN STEEL:

- Nichel-plated for standard version against internal and external corrosion.
- Stainless steel for corrosive environments upon request.
- Anti-blowout design.

6 CAM FOR LIMIT POSITION ADJUSTMENT 0°-90°:

- Stainless steel.
- Adjustment for open and close position $\pm 5^\circ$.

7 0-90° ADJUSTMENT SCREWS:

- Stainless steel.

8 PISTON GUIDES IN POM:

- Large contact area.
- Low friction for self lubricating material.
- Long life.

9 PISTONS MADE FROM DIE CAST ALUMINIUM:

- Chemical nickel plating upon request.

10 SEALS:

- NBR standard version.
- Viton high temperature version.
- Silicon low temperature version.

TWIN RACK AND PINION DESIGN:

- Constant torque output.
- Compact design.
- Balanced internal forces.
- Robust design to ensure long life.

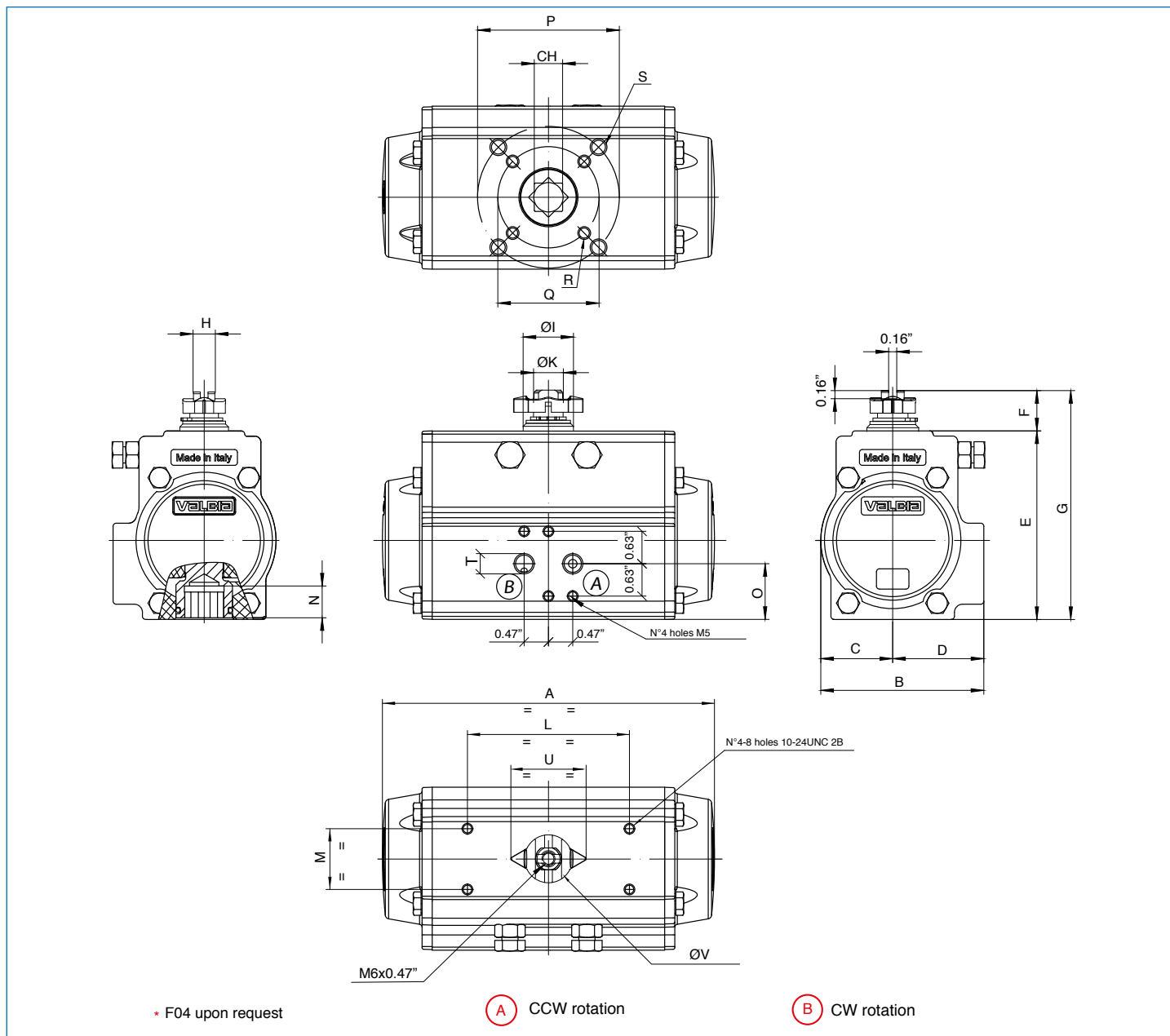

MOD.	DRILLING ISO 5211	CH	A	B	C	D	E	F	G	H	ØI	ØK	L	M	N	O	P	Q	R	S	T NPT	U	øV
52	F03-F05 *	0.43	5.55	2.80	1.18	1.61	3.21	0.79	4.00	0.39	0.83	0.47	3.15	1.18	0.47	1.04	1.97	1.42	10-24 UNC 2Bx0.29"	1/4-20 UNC 2Bx0.35"	1/8"	1.36	0.87
63	F05 - F07	0.55	6.46	3.17	1.40	1.77	3.66	0.79	4.45	0.43	0.98	0.59	3.15	1.18	0.63	1.08	2.76	1.97	1/4-20 UNC 2Bx0.31"	5/16-18 UNC 2Bx0.47"	1/8"	1.36	0.87
75	F05 - F07	0.67	8.27	3.72	1.65	2.07	4.37	0.79	5.16	0.51	1.14	0.75	3.15	1.18	0.75	1.38	2.76	1.97	1/4-20 UNC 2Bx0.31"	5/16-18 UNC 2Bx0.47"	1/8"	1.65	1.14
85	F05 - F07	0.67	9.47	4.17	1.87	2.30	4.92	0.79	5.71	0.59	1.38	0.86	3.15	1.18	0.75	1.65	2.76	1.97	1/4-20 UNC 2Bx0.31"	5/16-18 UNC 2Bx0.47"	1/8"	1.65	1.14
100	F07 - F10	0.67	10.83	4.84	2.17	2.68	5.43	0.79	6.21	0.59	1.38	0.86	3.15	1.18	0.81	1.97	4.02	2.76	5/16-18 UNC 2Bx0.31"	3/8-16 UNC 2Bx0.55"	1/4"	1.65	1.14
115	F07 - F10	0.87	13.11	5.39	2.52	2.87	6.39	1.18	7.57	0.87	1.93	1.26	3.15/5.12	1.18	0.94	1.97	4.02	2.76	5/16-18 UNC 2Bx0.47"	3/8-16 UNC 2Bx0.59"	1/4"	2.52	1.73
125	F07 - F10	0.87	14.65	5.83	2.68	3.15	6.87	1.18	8.05	0.87	1.93	1.26	3.15/5.12	1.18	0.94	2.40	4.02	2.76	5/16-18 UNC 2Bx0.47"	3/8-16 UNC 2Bx0.59"	1/4"	2.52	1.73
140	F10 - F12	1.06	17.13	6.46	3.01	3.44	7.76	1.18	8.94	0.94	1.93	1.38	3.15/5.12	1.18	1.14	2.80	4.92	4.02	3/8-16 UNC 2Bx0.59"	1/2-13 UNC 2Bx0.71"	1/4"	2.52	1.73
160	F10 - F12	1.06	19.69	7.32	3.43	3.90	8.70	1.18	9.88	1.18	2.24	1.57	3.15/5.12	1.18	1.26	3.15	4.92	4.02	3/8-16 UNC 2Bx0.55"	1/2-13 UNC 2Bx0.67"	1/4"	3.17	2.36
180	F10 - F14	1.42	19.41	8.38	3.86	4.53	9.96	1.18	11.14	1.42	2.44	1.77	3.15/5.12	1.18	1.69	3.90	5.51	4.02	3/8-16 UNC 2Bx0.59"	5/8-11 UNC 2Bx0.98"	1/4"	3.17	2.36
200	F14	1.42	22.76	8.54	4.25	4.29	10.94	1.18	12.13	1.42	2.64	1.97	3.15/5.12	1.18	1.46	3.07	5.51	/	/	5/8-11 UNC 2Bx0.94"	1/4"	3.17	2.36
230	F16	* 1.81	27.17	9.78	4.88	4.90	12.80	1.18	13.98	1.42	2.64	1.97	3.15/5.12	1.18	1.97	3.62	6.50	/	/	3/4-10 UNC 2Bx1.14"	1/4"	3.17	2.36

** Only square connection at 45°.