

# 1509\*/1509T\*\* 3/8"-3"

**Bronze Check Valve  
Horizontal Swing  
125 SWP-200 WOG†  
Bronze Disc • Solder Ends  
Conforms to: MSS SP-80. Type 3\*, Type 4\*\*  
Class 125, Solder Ends**

## MATERIAL LIST

NO.	PART	MATERIAL	SPECIFICATION
1	Body	Bronze	ASTM B 62
2	Cap	Bronze	ASTM B 62
3	Lever	St. Steel	Commercial
4	Disc	Brass - 1509	ASTM B 16 1/4" to 3/4"
			ASTM B 453 1" to 1 1/2"
		Bronze - 1509	ASTM B 62 2" to 3"
	PTFE - 1509T	Commercial	
5	Pin	St. Steel	Commercial
6	Plug (not shown)	Brass	ASTM B 16
7	Retaining Ring	St. Steel	Commercial

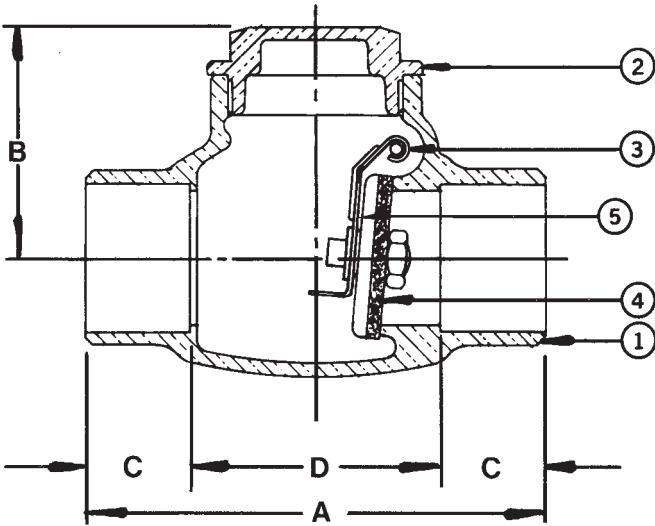

Note: Not intended for use in potable water.

## DIMENSIONS - INCHES / MILLIMETERS

UNITS	SIZE	A	B	C	D	C <sub>v</sub>
Inches	3/8	2.25	1.44	0.38	1.50	3.3
mm	9.5	57.2	36.5	9.5	38.1	
Inches	1/2	2.56	1.44	0.50	1.56	6.0
mm	12.7	65.1	36.5	12.7	39.7	
Inches	3/4	3.31	1.69	0.75	1.75	10.0
mm	19.1	84.2	42.9	19.1	44.5	
Inches	1	4.00	1.97	0.91	2.19	18.0
mm	25.4	101.6	50.0	23.0	55.6	
Inches	1 1/4	4.25	2.16	0.97	2.31	31.0
mm	31.8	108.0	54.8	24.6	58.8	
Inches	1 1/2	4.94	2.41	1.09	2.75	54.0
mm	38.1	125.4	61.1	27.8	69.9	
Inches	2	6.13	2.81	1.34	3.44	76.0
mm	50.8	155.6	71.5	34.1	87.3	
Inches	2 1/2	7.38	3.63	1.47	4.44	131.0
mm	63.5	187.3	92.1	37.3	122.7	
Inches	3	8.50	4.81	1.66	5.19	192.0
mm	76.2	215.9	106.4	42.1	131.8	

† Non-Shock

Rev. 13

**INNOVATION** IN EVERY VALVE



**MILWAUKEE VALVE**

The information presented on this sheet is correct at the time of publication. Milwaukee Valve reserves the right to change design, and/or material specifications without notice. For the Installation, Operation and Maintenance Manual (IOM) see the engineering section on our website. For the most current information access [www.milwaukeevalve.com](http://www.milwaukeevalve.com)

[www.milwaukeevalve.com](http://www.milwaukeevalve.com)