



Drawing#:

5048Y0

**050 Series
Ductile Iron Wafer
Resilient Seated
Butterfly Valve**

**△ P 200/150
Differential Pressure**

Sized for 80 PSI

**Applicable Trims:
262, 263, 579, 582,
780, 783, 962**



REV: 0 Date: 5/21/20

AUTOMATED BUTTERFLY VALVE ASSEMBLY

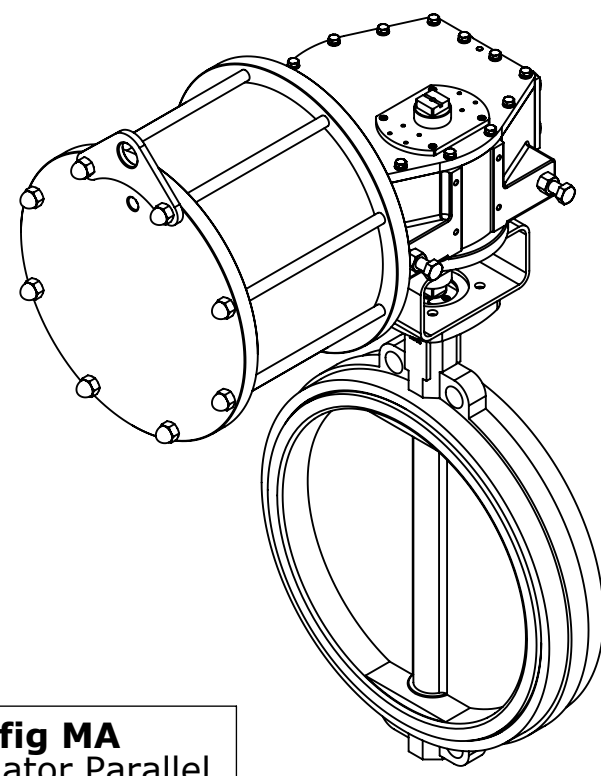

Config MA
Actuator Parallel
to Pipeline
Double Acting

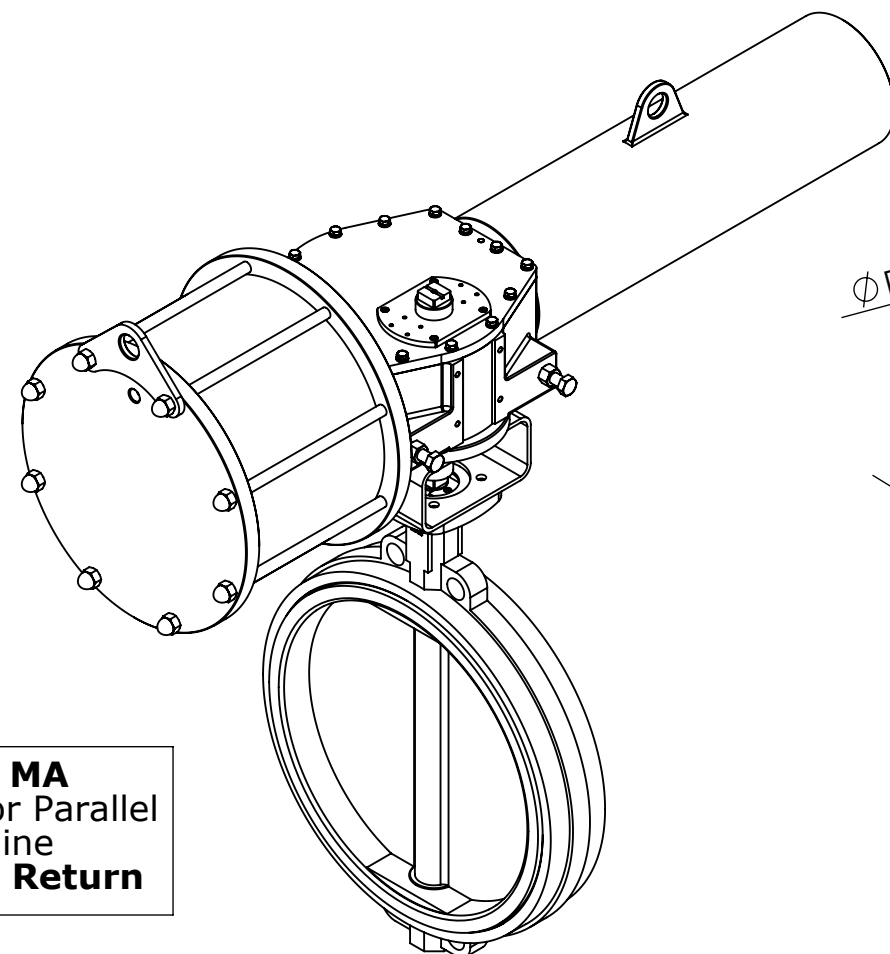
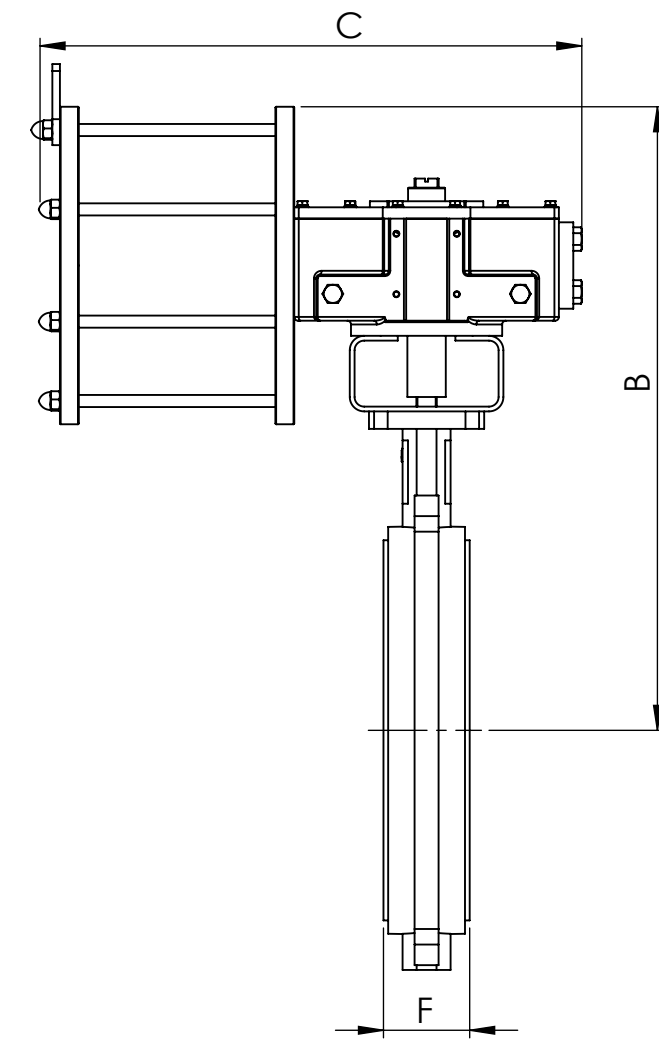
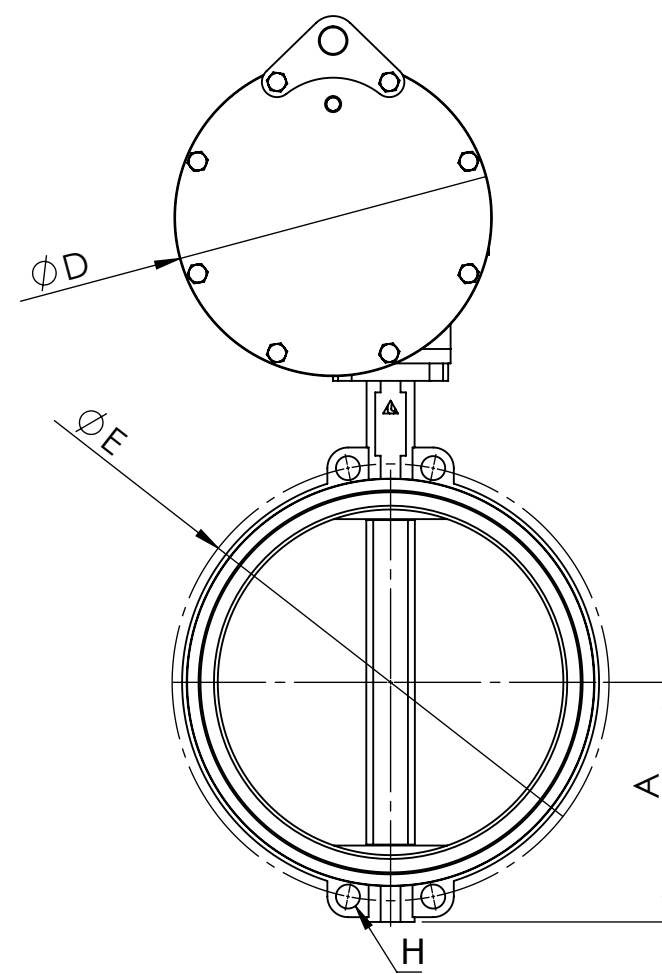

Config MA
Actuator Parallel
to Pipeline
Spring Return

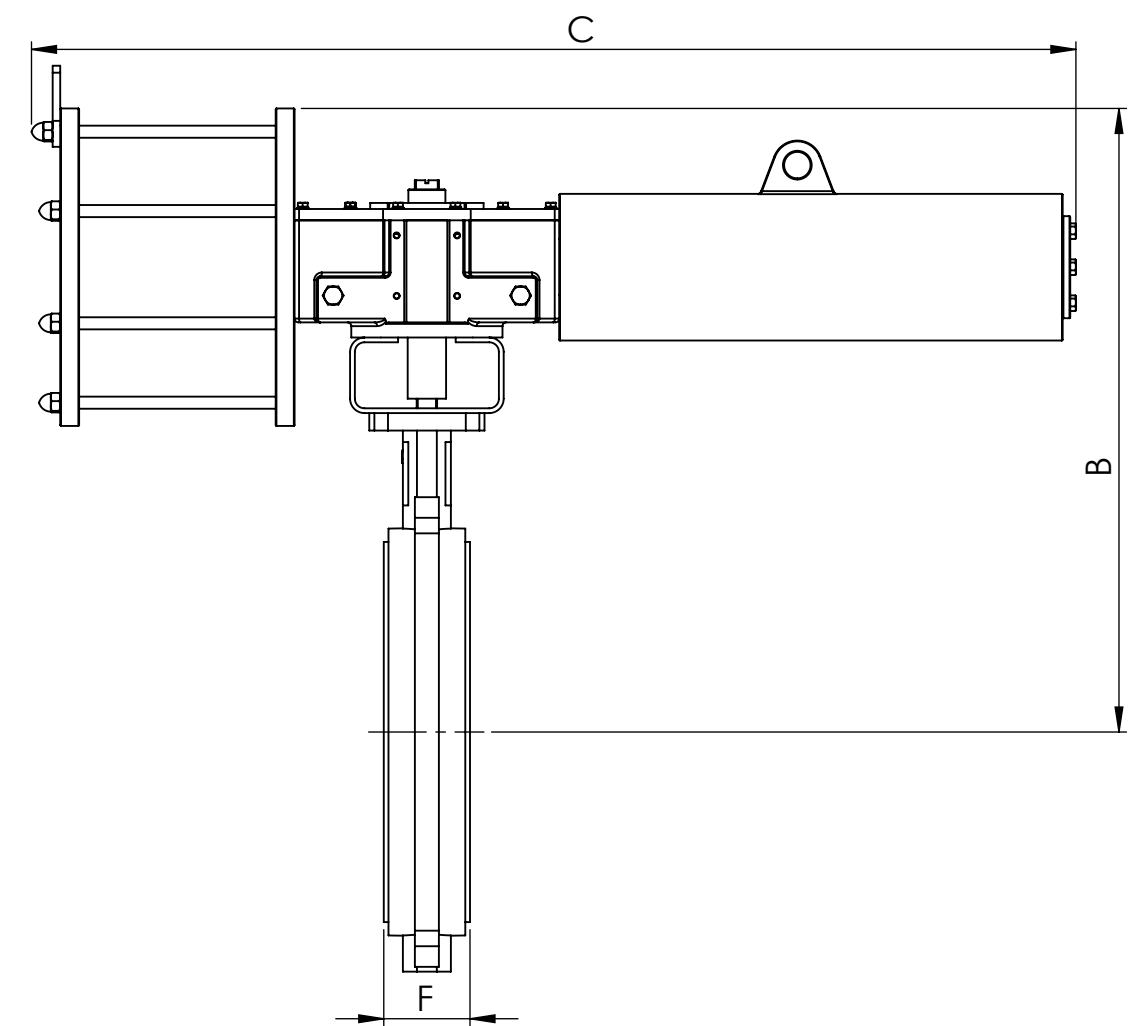
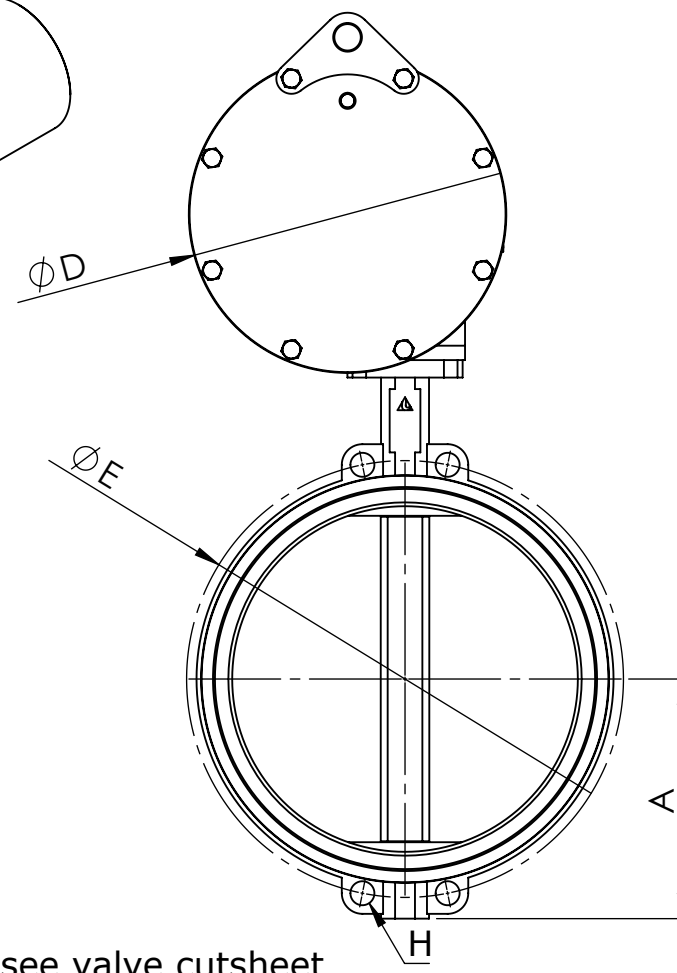

For smaller sizes Reference Drawing:

5048M0

For Jackscrew/Handpump

Option Reference Drawing:

5048YH

*For MB Actuator Mounted
Perpendicular to Valve Please
Contact Manufacturer

*All dimensions in INCHES *All weights in POUNDS *For valve specific Features and Dimensions see valve cutsheet

ACTION	SERVICE	SIZE	A	B	C	D	E	F	H	MOUNTING	ACTUATOR	WEIGHT
DOUBLE ACTING	WET MEDIA	18"	12.8	29.4	31.5	12.7	22.8	4.5	4 x 1.25	KY16-D180	SHD16-U025001	427
		20"	14.2	32.1	31.5	14.7	25.0	5.0	4 x 1.25	KY16-D200	SHD16-U030001	526
		24"	16.5	35.1	31.5	16.1	29.5	6.1	4 x 1.38	KY16-D240	SHD16-U035001	760
	SERVICE	SIZE	A	B	C	D	E	F	H	MOUNTING	ACTUATOR	WEIGHT
	DRY AIR	18"	12.8	29.4	31.5	12.7	22.8	4.5	4 x 1.25	KY16-D180	SHD16-U025001	427
		20"	14.2	32.1	31.5	14.7	25.0	5.0	4 x 1.25	KY16-D200	SHD16-U030001	526
24"		16.5	35.1	31.5	16.1	29.5	6.1	4 x 1.38	KY16-D240	SHD16-U035001	760	
ACTION	SERVICE	SIZE	A	B	C	D	E	F	H	MOUNTING	ACTUATOR	WEIGHT
SPRING RETURN	WET MEDIA	12"	9.3	25.8	52.2	12.7	17.0	3.1	4 X 1.02	KY16-D120	SHD16-U025A01	444
		14"	10.3	26.8	52.2	12.7	18.8	3.1	4 x 1.14	KY16-D140	SHD16-U025A01	470
		16"	11.8	29.0	52.2	14.7	21.3	4.0	4 x 1.14	KY16-D160	SHD16-U030B01	559
		18"	12.8	31.0	52.2	16.1	22.8	4.5	4 x 1.25	KY16-D180	SHD16-U035B01	680
		20"	14.2	34.8	59.4	16.1	25.0	5.0	4 x 1.25	KY25-D200	SHD25-U035B01	1003
		24"	16.5	39.3	59.4	20.2	29.5	6.1	4 x 1.38	KY25-D240	SHD25-U043B01	1337
	SERVICE	SIZE	A	B	C	D	E	F	H	MOUNTING	ACTUATOR	WEIGHT
	DRY AIR	12"	9.3	25.8	52.2	12.7	17.0	3.1	4 X 1.02	KY16-D120	SHD16-U025A01	444
		14"	10.3	26.8	52.2	12.7	18.8	3.1	4 x 1.14	KY16-D140	SHD16-U025A01	470
		16"	11.8	29.0	52.2	14.7	21.3	4.0	4 x 1.14	KY16-D160	SHD16-U030B01	559
		18"	12.8	31.0	52.2	16.1	22.8	4.5	4 x 1.25	KY16-D180	SHD16-U035B01	680
		20"	14.2	35.8	59.4	18.1	25.0	5.0	4 x 1.25	KY25-D200	SHD25-U038B01	1070
24"		16.5	39.9	59.4	20.2	29.5	6.1	4 x 1.38	KY30-D240	SHD30-U043B01	1618	