



Serie **COMMERCIAL STYLE**

Articolo **1715 - 1725**

- Brass ball valve with solder ends, full port sizes 1/2" to 4".
- Pressure rating 600 WOG - 150 WSP.
  - Temperature to 366°F.
  - Blow out proof stem, chrome plated brass ball.
  - P.T.F.E. seats, seals, and thrust washer.
  - Adjustable stem packing.
  - 100% electronically tested in the open and closed position at 80 psi.

MEETS THE DESIGN CRITERIA OF MSS\_SP\_110

1715: LEVER HANDLE - size 1/2" to 4".  
1725: T HANDLE - size 1/2" to 1".

CONNECTION: ANSI B 16.18

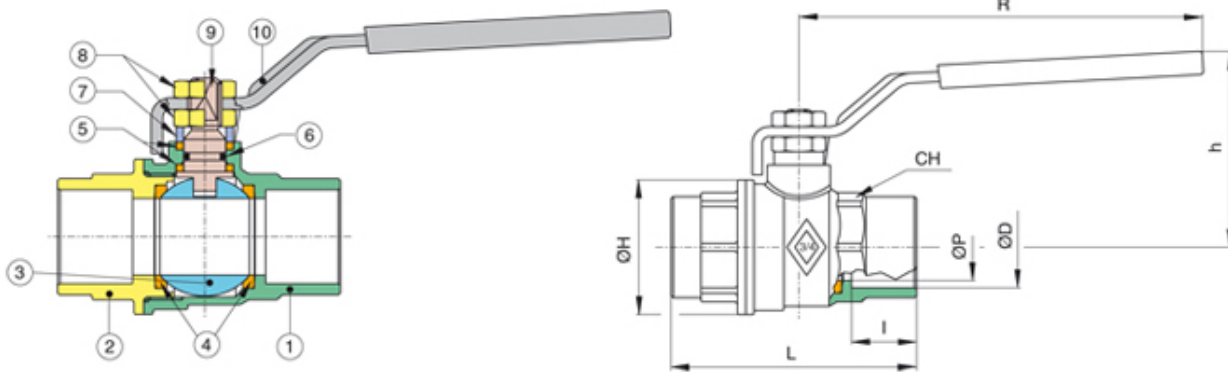

The Buna O-ring is fitted to the stem of the valve as the best possible protection against potential leakage under extreme duty, or low pressure applications. A secondary PTFE stem seal will also assure that the valve is suitable for use up to 366° F.

N Pos	PART NAME	MATERIAL	N PCS
1	BODY	BRASS CW 617N UNI EN 12165	1
2	END CONNECTION	BRASS CW 617N UNI EN 12165	1
3	BALL	BRASS CW 617N UNI EN 12165	1
4	BALL SEAT	P.T.F.E	2
5	THRUST WASHER/STEM SEAT	P.T.F.E	2
6	O-RING	NBR	1
7	PACKING GLAND	BRASS CW 614N UNI EN 12164	1
8	NUT	Steel 6S	2
9	STEM	BRASS CW 614N UNI EN 12164	1
10	HANDLE	Fe DD11 UNI EN 10111	1

SIZE	ØP	L	I	h	R	ØH	ØH	CH	CV	psi	Lbs
1/2"	0.59	2.58	0.50	1.81	3.86	0.63	1.30	0.98	18.90	600	0.50
3/4"	0.79	3.00	0.75	2.28	4.80	0.88	1.53	1.22	34.22	600	0.77
1"	0.98	3.56	0.91	2.44	4.80	1.13	1.93	1.50	49.88	600	1.19
1"1/4	1.26	4.09	0.96	3.00	6.02	1.38	2.32	1.90	103.00	600	2.20
1"1/2	1.57	4.56	1.10	3.23	6.02	1.63	2.87	2.12	266.10	600	3.24



2"	1.95	5.45	1.34	3.74	6.38	2.13	3.38	2.64	307.00	600	4.21
2"1/2	2.40	6.90	1.47	4.84	8.07	2.63	4.37	3.54	624.00	600	9.44
3"	2.87	8.05	1.67	5.23	8.07	3.13	5.35	4.13	1009.00	600	14.52
4"	3.82	10.25	2.16	6.49	10.24	4.13	6.53	5.12	1067.00	600	24.83