



JOB NAME:	CONTRACTOR:
JOB LOCATION:	APPROVAL:
ENGINEER:	CONTRACTOR P.O.:
APPROVAL:	REPRESENTATIVE:

8E0630-00* - 8E0631-00* - 8E0632-00*
FNPT THREADED SOCKET WELD BUTT WELD

630LL DIRECT MOUNT, 3-PC, 2-WAY CARBON STEEL, CLASS 900 FULL PORT BALL VALVE IN NPT, SW OR BUTT WELD W/VALBIA ELECTRIC ACTUATOR SIZES 1/4" TO 4"

*001	12V AC/DC	*002	24V AC/DC	*003	100-240V AC
01	BATTERY BACKUP	*02*	POSITIONER	*04*	BATTERY BACKUP W POSITIONER

SPECIFICATIONS

The 8E0630/8E0631/8E0632 series packages feature a carbon steel high performance three-piece full port, encapsulated bolt style, Class 900 [1/4"-2", Class 600 2 1/2"-4"] ball valve. The valve also incorporates an ISO 5211 direct mount pad with square stem. Further, the valve has high temperature TFM-4215 seats, conforms to ANSI 16.34, ANSI B1.20.1 Thread depths, NACE MRO 175, latch locking handle and an API 607 6th edition fire safe option. The Valbia VB electric actuator features a NEMA 4, 4X housing, two extra limit switches, dual voltage motors, a heater and thermostat, torque limiter, special manual override, and a 75% duty cycle motor. PG11 connections are standard, with optional 1/2" conduit.

ACTUATOR FEATURES

- NEMA 4, 4X Housing
- 12V/24V AC/DC and 100-240V AC Models Available
- ISO 5211 dual patterns
- VB015 -12/24V AC - 50% Duty Cycle
- VB030-VB110 - 12/24V DC and 100-240V AC - 75% Duty Cycle
- High-Strength, Impact Resistant IP67 Technopolymer Housing
- Temperature Range -4°F to 131°F
- PG11 Electrical Connection/Optional 1/2" conduit connection

VALVE FEATURES

- 3-piece WCB body
- Class 900 sizes 1/4" to 2", Class 600 sizes 2-1/2" to 4"
- Carbon steel-2200 psi (1/4" to 2"), 1500 psi (2-1/2" to 4")
- ISO 5211 mounting pad w/ square stem
- TFM-4215 ball seats
- Standard latch locking handle
- Conforms to ANSI 16.34, ANSI B1.20.1 thread depths, NACE MR0175
- Fire Safe to API 607-6th edition
- Grounded ball and stem
- Standard 316 stainless steel ball and stem
- Temperature range: -50° F to 550° F

BILL OF MATERIALS FOR 630LL / 631LL / 632LL

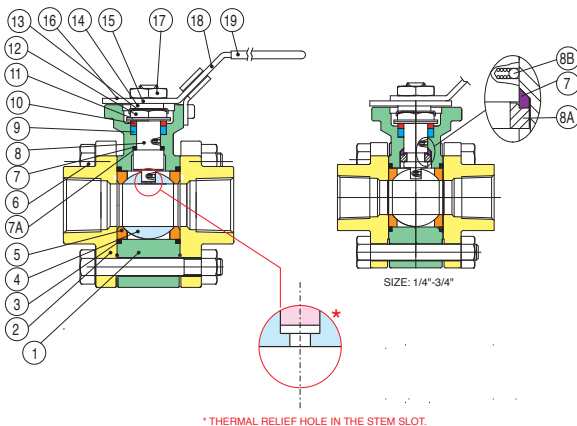

N POS	PART NAME	MATERIAL	N PCS
1	BODY	WCB	1
2	END CAP	WCB	2
3	GASKET BODY	TFM	2
4	BALL	SS316	1
5	BALL SEATS	TFM-4215	2
6	BOLTS	SS304	*
7	THRUST WASHER	TFM	1
7A	THRUST WASHER	PEEK	1
8	STEM	SS316	1
8A	HALF SPLIT RING	SS316	1
8B	ANTI-STATIC	SS316	2

N POS	PART NAME	MATERIAL	N PCS
9	STEM PACKING	TFM	1
10	GLAND WASHER	SS304	1
11	DISK WASHER	SS301	1
12	STEM NUT	SS304	1
13	NUT STOP	SS304	1
14	SPACE WASHER	SS304	1
15	PLATER	SS304	1
16	STOP IN	SS304	1
17	HANDLE NUT	SS304	1
18	HANDLE	SS304	1
19	HANDLE COVER	PLASTISOL	1

*VARIES WITH SIZE

VB015

SIZES 1/4" THROUGH 1/2"

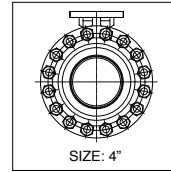
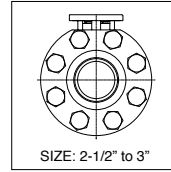
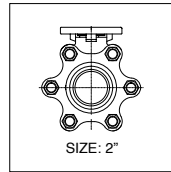
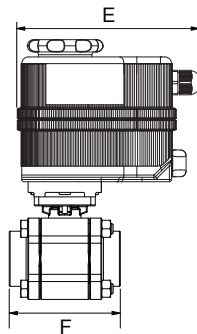
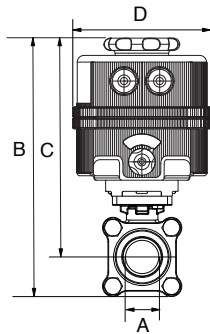

VB030-VB190

SIZES 3/4" THROUGH 4"

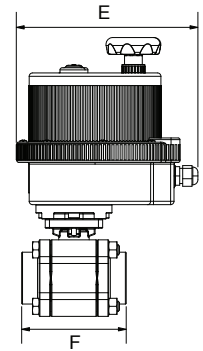
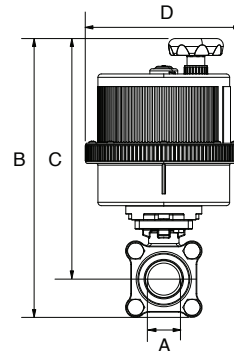

DIMENSIONS

Size	A	B	C	D	E	F	ACT.
1/4"	.250	8.38	7.38	4.84	6.41	2.62	VB015
3/8"	.375	8.38	7.38	4.84	6.41	2.62	VB015
1/2"	.500	8.50	7.46	4.84	6.41	2.76	VB015
3/4"	.750	10.64	9.49	6.18	7.48	3.62	VB030
1"	1.00	11.00	9.72	6.18	7.48	4.14	VB030
1-1/4"	1.25	12.25	10.90	7.28	8.43	4.37	VB060
1-1/2"	1.50	12.73	11.22	7.28	8.43	4.89	VB060
2"	2.00	14.64	12.69	8.31	9.33	5.91	VB110
2-1/2"	2.50	15.55	13.28	8.31	9.33	6.50	VB110
3"	3.00	16.41	13.83	8.31	9.33	7.68	VB110
4"	4.00	17.93	14.81	8.31	9.33	9.65	VB190

ON/OFF WIRING DIAGRAMS

12V AC/DC, 24V AC/DC & 100-240VAC

VB015 WIRING

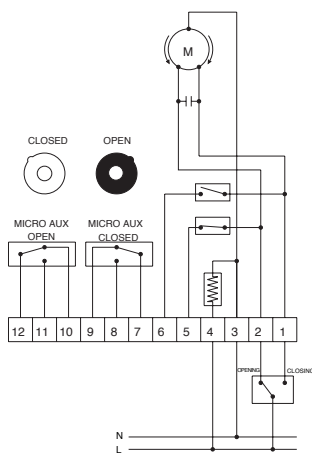

100-240V AC

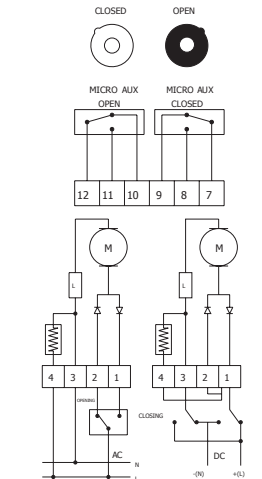

12V AC/DC & 24V AC/DC

VB030-VB190 WIRING

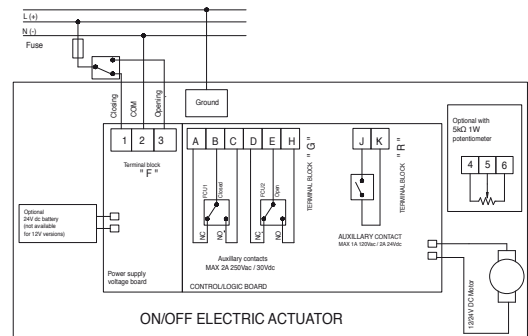

ON/OFF ELECTRIC ACTUATOR

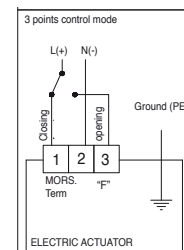
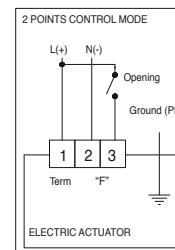

POSITIONER WIRING DIAGRAM

12V AC/DC, 24V AC/DC & 100-240VAC

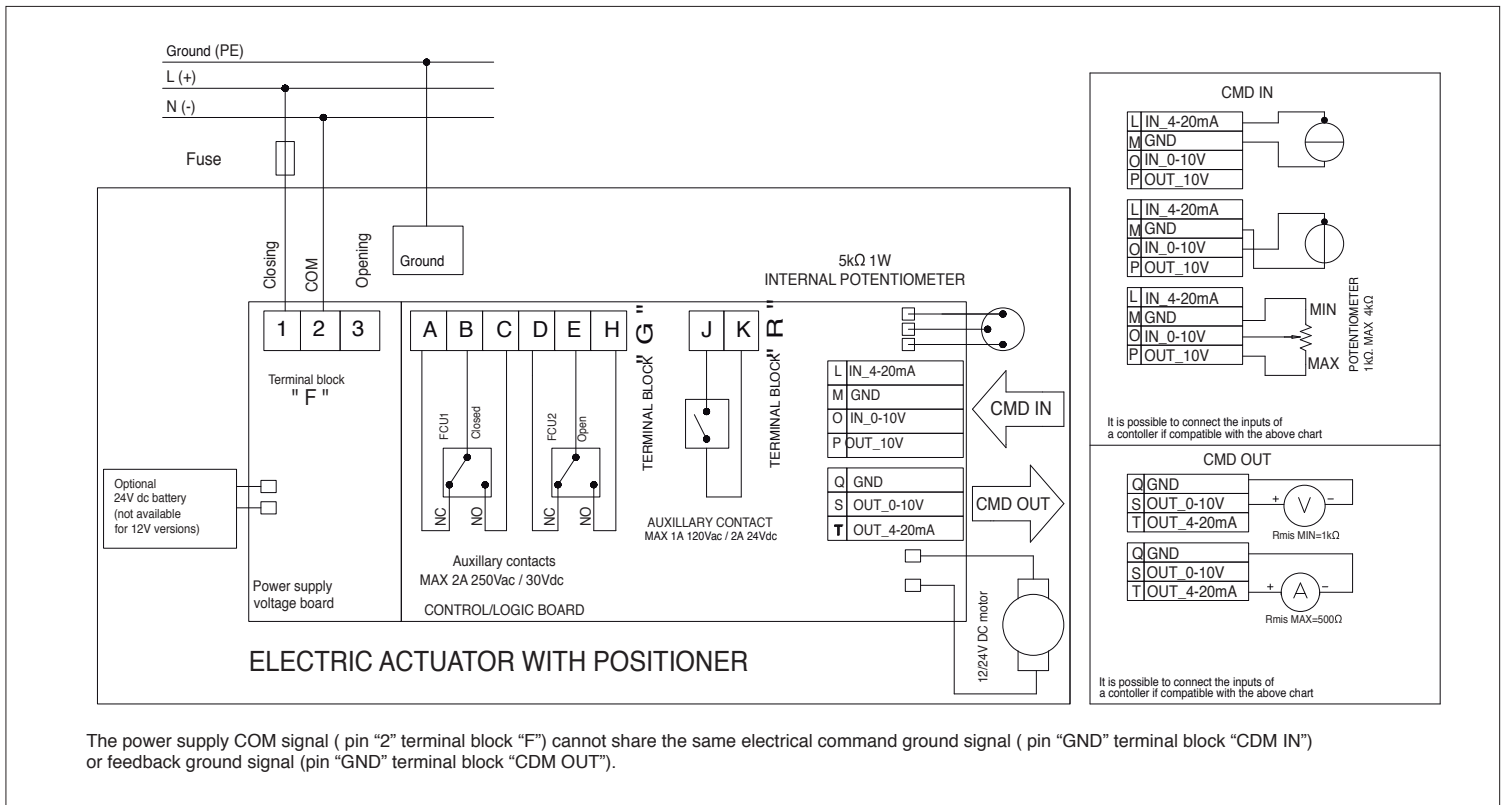

3-POSITION WIRING DIAGRAM

12V AC/DC, 24V AC/DC & 100-240VAC

