

JOB NAME:	CONTRACTOR:
JOB LOCATION:	APPROVAL:
ENGINEER:	CONTRACTOR P.O.:
APPROVAL:	REPRESENTATIVE:

8P0173

720016 2-WAY STAINLESS STEEL, ANSI 150 FLANGED, WAFER STYLE, FULL PORT BALL VALVE WITH DOUBLE ACTING ACTUATOR AND BRACKET

SIZES 1/2" TO 6"

8P0174

720016 2-WAY STAINLESS STEEL, ANSI 150 FLANGED, WAFER STYLE, FULL PORT BALL VALVE WITH SPRING RETURN ACTUATOR AND BRACKET

SIZES 1/2" TO 6"

SPECIFICATIONS

The Bonomi 8P0173/8P0174 series pneumatic packages feature the 720016 made from ASTM A351-CF8M stainless steel, short pattern, wafer full port, ANSI 150 flanged ball valve, in sizes 1/2"-6".

This space saving valve also meets ANSI 16.34, ANSI 16.5, NACE MR 0175/ISO 15156 and NACE MR 0103. It has RTFE seats, and a combination PTFE and Viton dual stem packing design.

The Valbia pneumatic actuator comes with a hard-anodized aluminum body, and powder coated end caps. In addition, all Valbia pneumatic actuators are standardly furnished with elevated temperature seals to 302°F. The patented side loaded limit stops never enter the piston chamber eliminating extra possible leak paths.

ACTUATOR FEATURES

- Hard anodized extruded aluminum body
- Concentric spring sets
- Die cast aluminum end caps
- Solid steel barstock pinion (not casting)
- 0°-90° rotation adjustment cam
- 0°-90° rotation adjustment bolts
- POM piston guides
- Minimum air pressure rating: 80 psi
- Maximum air pressure rating: 116 psi
- Working temperature: -4°F - 302°F
- No lubrication maintenance required for the entire actuator lifetime
- 100% factory tested

VALVE FEATURES

- Stainless Steel, ANSI class 150 flanged
- Full port, sizes 1/2" to 6"
- Temperature range -4°F to 400°F
- Blow-out proof stem
- R.P.T.F.E. seats, packing and thrust washer
- Space saving design
- 100% tested
- TUV T.A. Luft approved
- ANSI B16.34 design
- ISO 5211 mounting pad with double "D" stem

PRESSURE - TEMPERATURE CHART FOR SERIES 720016

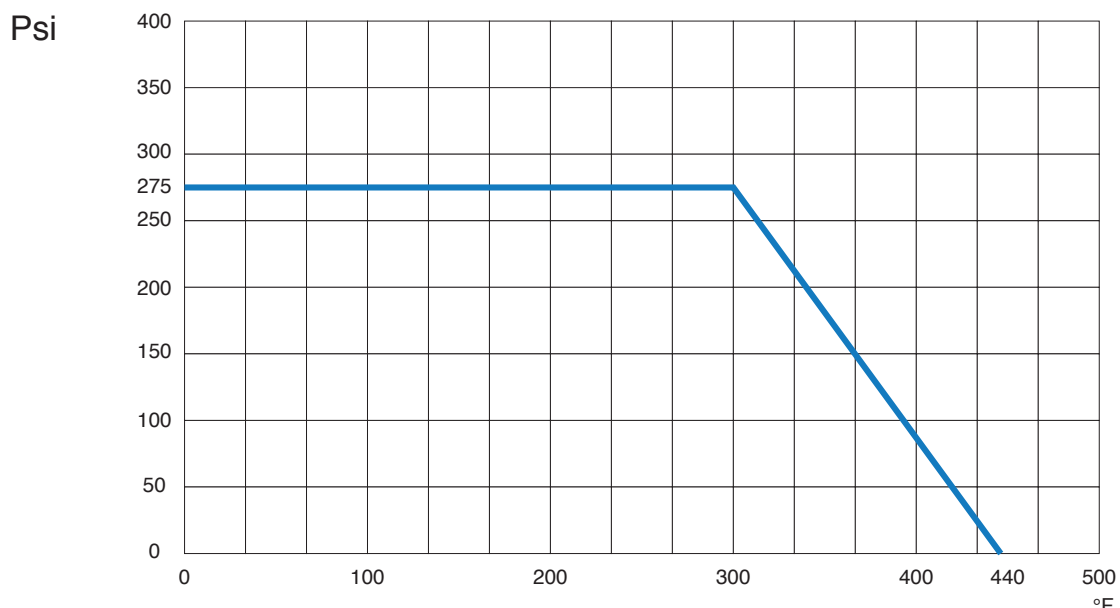

BILL OF MATERIALS FOR 720016

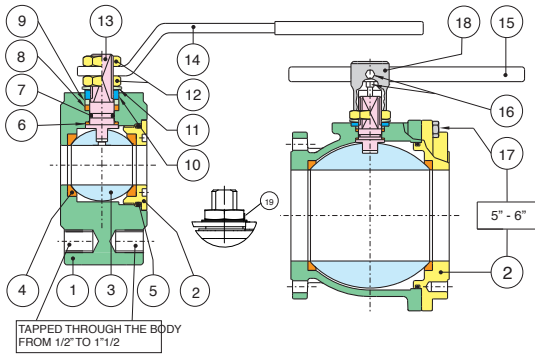

N POS	PART NAME	MATERIAL	N PCS
1	BODY	A479-316/A351 CF8M	1
2	END CONNECTION	A479-316/A351 CF8M	1
3	BALL	A479-316/A351 CF8M	1
4	BALL SEATS	R.P.T.F.E.	2
5	O-RING	FKM (Viton®)	1
6	THRUST WASHER	P.T.F.E.	1
7	RING	FKM (Viton®)	1
8	STEM SEAL	P.T.F.E.	1
9	PACKING GLAND	STEEL	1
10	END STOP	AISI 430 (1/2" - 2") STEEL (2-1/2" - 6")	2 1

N POS	PART NAME	MATERIAL	N PCS
11	SPRING WASHER	STEEL	2
12	NUT	STEEL	2
13	STEM	A479-316	1
14	HANDLE	STEEL	1
15	HANDLE DN 150-200	STEEL	1
16	SCREW	STEEL	2
17	SCREW	STEEL	8-12
18	BODY HANDLE DN150-200	CAST IRON	1
19	UNSCREWING GROWER	A182-F316	1

DIMENSIONS

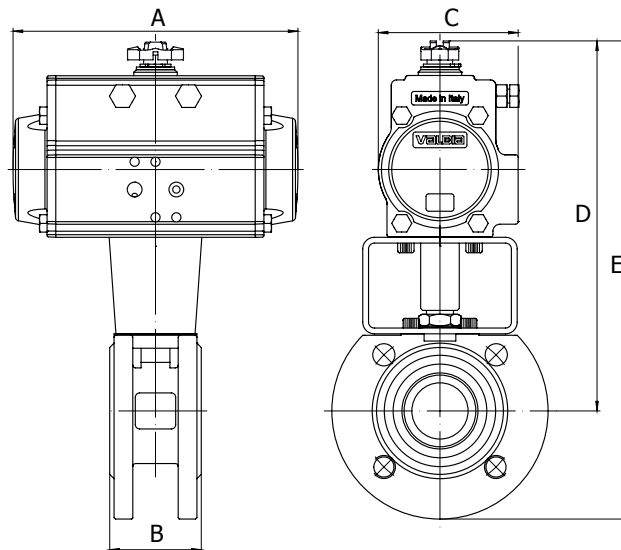

8P0173

720016 W/ **DOUBLE ACTING** ACTUATOR

Size	A	B	C	D	E	ACT. DA
1/2"	4.33	1.37	1.77	5.78	7.55	32
3/4"	5.55	1.57	2.80	7.40	9.37	52
1"	5.55	1.81	2.80	7.59	10.19	52
1-1/4"	5.55	2.12	2.80	7.87	10.62	52
1-1/2"	6.46	2.50	3.17	8.93	11.88	63
2"	8.27	3.22	3.72	9.96	13.22	75
2-1/2"	9.47	4.05	4.17	11.10	14.88	85
3"	9.47	4.80	4.17	11.49	14.43	85
4"	10.83	5.98	4.84	13.42	17.75	100
5"	13.11	7.71	5.39	15.66	20.59	115
6"	14.65	9.13	5.83	17.12	22.71	125

8P0174

720016 W/ **SPRING RETURN** ACTUATOR

Size	A	B	C	D	E	ACT. SR
1/2"	5.55	1.37	2.80	7.20	8.97	52
3/4"	6.46	1.57	3.17	7.89	9.84	63
1"	6.46	1.81	3.17	8.07	10.34	63
1-1/4"	6.46	2.12	3.17	8.34	11.29	63
1-1/2"	9.47	2.50	4.14	10.19	13.14	85
2"	10.83	3.22	4.84	11.06	14.29	100
2-1/2"	13.11	4.05	5.39	13.74	17.51	115
3"	14.65	4.80	5.83	14.64	18.54	125
4"	14.65	5.98	5.83	15.23	19.56	125
5"	17.13	7.71	6.46	17.00	21.92	140
6"	19.69	9.13	7.32	18.93	24.56	160