

JOB NAME:	CONTRACTOR:
JOB LOCATION:	APPROVAL:
ENGINEER:	CONTRACTOR P.O.:
APPROVAL:	REPRESENTATIVE:

8P760150

760150 2-WAY CARBON STEEL, ANSI 600 FLANGED, SPLIT BODY STYLE, FULL PORT BALL VALVE WITH **DOUBLE ACTING ACTUATOR**

SIZES 1/2" TO 4"

8P760151

760150 2-WAY CARBON STEEL, ANSI 600 FLANGED, SPLIT BODY STYLE, FULL PORT BALL VALVE WITH **SPRING RETURN ACTUATOR**

SIZES 1/2" TO 4"

SPECIFICATIONS

The 8P760150/8P760151 pneumatic actuated packages feature the full port, ANSI Class 600 series 760150 in carbon steel, with metal core PTFE seats. The 760150 is Fire-Safe to API 607, 6th edition, has a grounded ball & stem, meets NACE MR0175/NACE 0130/ISO 15156, AN SI B16.5, B16.10, and B16.34.

The Valbia pneumatic actuator comes with a hard-anodized aluminum body, and powder coated end caps. In addition, all Valbia pneumatic actuators are standardly furnished with elevated temperature seals to 302°F. The patented side loaded limit stops never enter the piston chamber eliminating extra possible leak paths.

ACTUATOR FEATURES

- Hard anodized extruded aluminum body
- Concentric spring sets
- Die cast aluminum end caps
- Solid steel barstock pinion (not casting)
- 0°-90° rotation adjustment cam
- 0°-90° rotation adjustment bolts
- POM piston guides
- Minimum air pressure rating: 80 psi
- Maximum air pressure rating: 116 psi
- Working temperature: -4°F - 302°F
- No lubrication maintenance required for the entire actuator lifetime
- 100% factory tested

VALVE FEATURES

- Carbon Steel, ANSI class 600 flanged
- Full port, sizes 1/2" to 4"
- Temperature range -4°F to 400°F
- Blow-out proof stem, adjustable stem packing
- P.T.F.E. seats, packing and thrust washer
- 100% tested
- PED 97/23/CE
- ANSI B16.5, B16.10, B16.34 design
- Fire Safe API 6FA-API 607 4th edition
- Antistatic Device
- ISO 5211 mounting pad with double "D" stem

PRESSURE - TEMPERATURE CHART FOR SERIES 760150

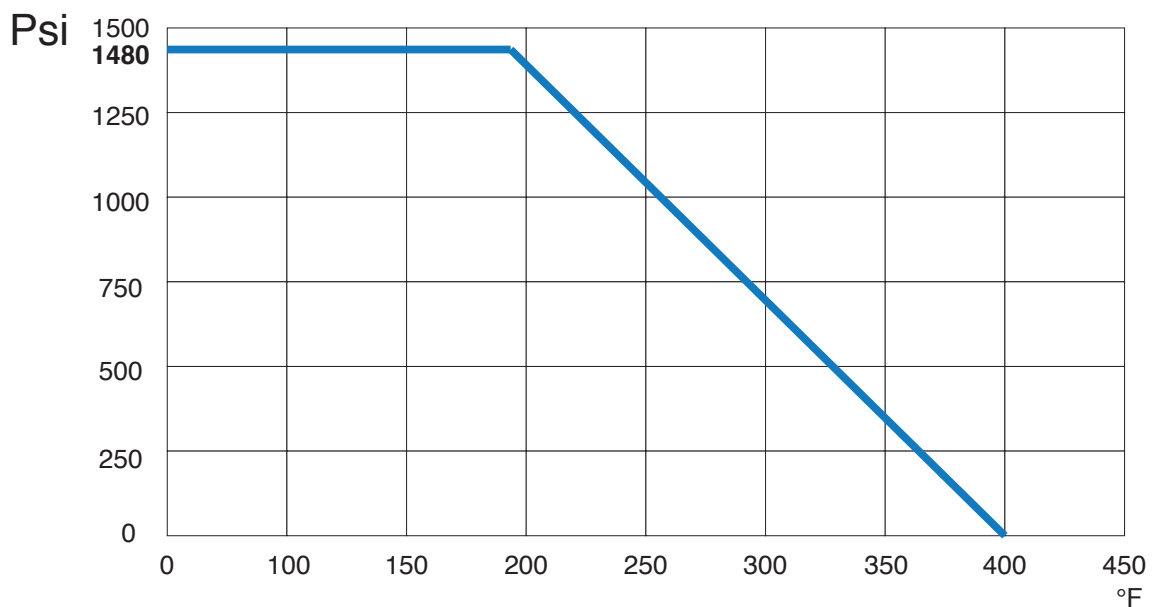

BILL OF MATERIALS FOR 760150

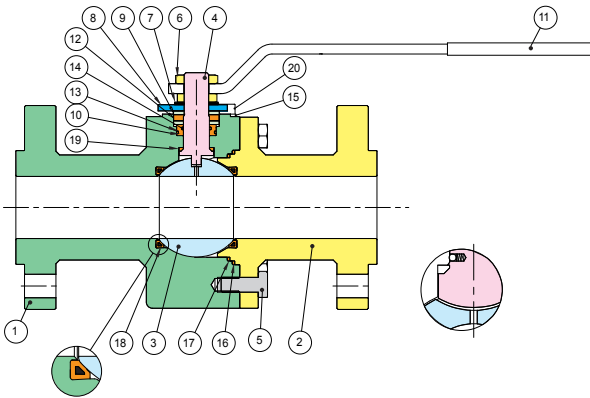

N POS	PART NAME	MATERIAL	N PCS
1	BODY	A350-LF2	1
2	END CONNECTION	A350-LF2	1
3	BALL	A479-304/A351 CF8	1
4	STEM	A479-304	1
5	SCREW	CARBON STEEL	4-8
6	NUT	CARBON STEEL	1-2
7	SPRING WASHER	CARBON STEEL	2
8	90° STOP	CARBON STEEL	1
9	PACKING GLAND	STAINLESS STEEL	2
10	STEM SEAL	P.T.F.E.	1
11	HANDLE	CARBON STEEL	1

N POS	PART NAME	MATERIAL	N PCS
12	STEM SEAL	GRAPHOIL	1
13	O-RING	FKM (Viton®)	1
14	O-RING	FKM (Viton®)	1
15	THRUST WASHER	STAINLESS STEEL	2
16	BODY SEAL	GRAPHOIL	1
17	SEAL	P.T.F.E.	1
18	BALL SEAT	R.P.T.F.E.	2
19	THRUST WASHER	P.T.F.E.	1
20	SCREW	STAINLESS STEEL	2

DIMENSIONS

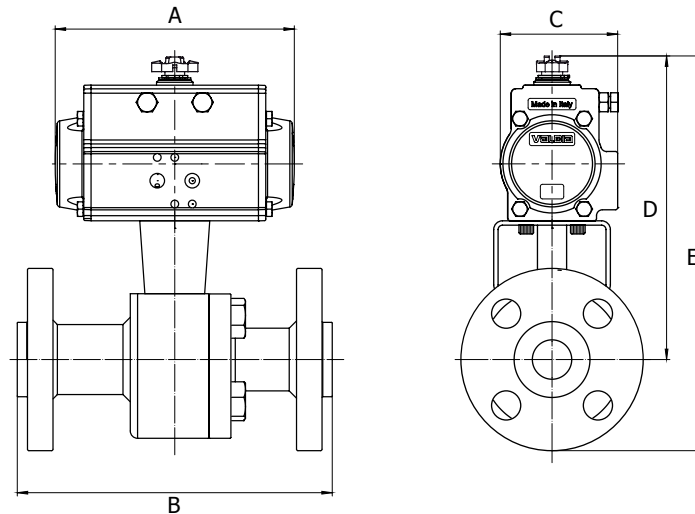

8P760150

760150 W/ **DOUBLE ACTING** ACTUATOR

Size	A	B	C	D	E	ACT. DA
1/2"	5.55	6.50	2.80	7.28	9.13	52
3/4"	5.55	7.52	2.80	7.40	9.68	52
1"	6.46	8.50	3.17	8.58	11.06	63
1-1/2"	9.47	9.49	4.17	11.02	14.09	85
2"	9.47	11.50	4.17	10.98	14.21	85
3"	14.65	14.02	5.83	14.84	18.97	125
4"	19.69	17.01	7.32	16.88	22.32	160

8P0760151

760150 W/ **SPRING RETURN** ACTUATOR

Size	A	B	C	D	E	ACT. SR
1/2"	6.46	6.50	3.17	7.71	9.60	63
3/4"	8.27	7.52	3.72	8.58	10.28	75
1"	9.47	8.50	4.17	9.84	12.32	85
1-1/2"	13.11	9.49	5.39	12.91	15.94	115
2"	13.11	11.50	5.39	12.83	16.10	115
3"	19.69	14.02	7.32	16.65	20.78	160
4"	19.41	17.01	8.39	19.09	24.52	180