



JOB NAME:	CONTRACTOR:
JOB LOCATION:	APPROVAL:
ENGINEER:	CONTRACTOR P.O.:
APPROVAL:	REPRESENTATIVE:

8EPVCBV2

PVC-BV2 DIRECT MOUNT, 2-WAY PVC, FULL PORT BALL VALVE W ELECTRIC ACTUATOR SIZES 1/2" TO 4"

8E3LPVC - 8E3TPVC

PVC-BV3T OR PVC-BV3L DIRECT MOUNT, 3-WAY PVC, FULL PORT BALL VALVE W ELECTRIC ACTUATOR SIZES 1/2" TO 4"

*001 12V AC/DC	*002 24V AC/DC	*003 100-240V AC
01 BATTERY BACKUP	*02* POSITIONER	*04* BATTERY BACKUP W POSITIONER

SPECIFICATIONS

The valve body, stem, ball and unions shall be made of PVC compound which shall meet classification 12454 of ASTM D 1784. The ball seats shall be made of PTFE and the O-Ring seals shall be made of EPDM.

The PVC IPS/Socket connectors shall conform to the dimensional standards ASTM D2466 and ASTM D2467, and the CPVC shall conform to the dimensional standard ASTM F439 (2-way only). The NPT PVC connectors shall conform to the dimensional standards of ASTM D2464, ASTM F1498, and ANSI B1.20.1 thread depths.

The electric actuator shall be made from a light weight techno polymer housing, incorporate two auxiliary limit switches, a torque limiter, heater & thermostat, a 75% duty cycle, dual voltage motors, and a NEMA 4 enclosure.

ACTUATOR FEATURES

- NEMA 4, 4X Housing
- 12V/24V AC/DC and 100-240V AC Models Available
- ISO 5211 dual patterns
- VB015 -12/24V AC - 50% Duty Cycle
- VB030-VB110 - 12/24V DC and 100-240V AC - 75% Duty Cycle
- High-Strength, Impact Resistant IP67 Technopolymer Housing
- Temperature Range -4°F to 131°F
- PG11 Electrical Connection/Optional 1/2" Conduit

VALVE FEATURES

- 2-Way and 3-Way Full Port
- Size Range 1/2" Through 4"
- NPT and Socket Ends included
- EPDM Seats and Seals
- Dual Union Nut Locks
- 232 PSI at 73°F
- Viton Seats and Seals Available

PRESSURE – TEMPERATURE CHART FOR SERIES PVCBV2 & PVCBV3*

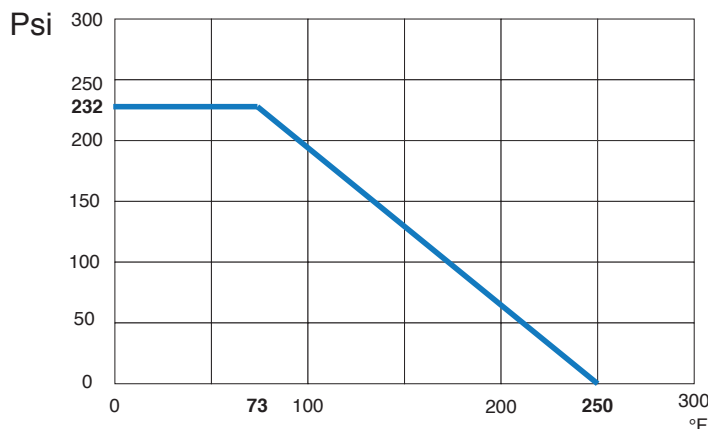

FLOW PATH VARIATIONS

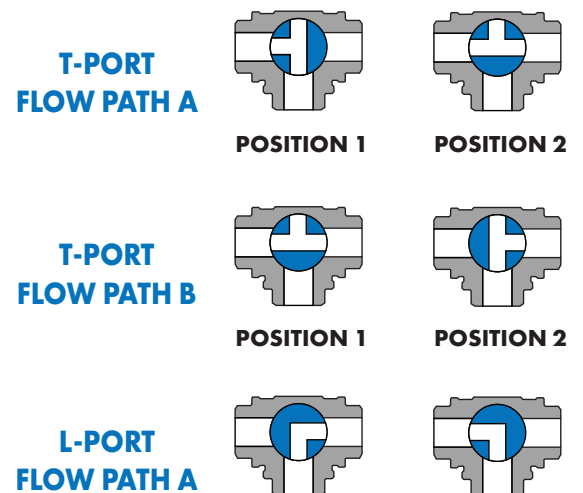

DIMENSIONS

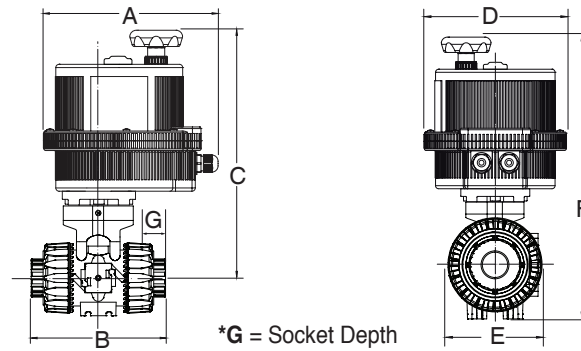

8EPVCBV2

Size	A	B	C	D	E	F	G	Actuator	Cv	Wt.
1/2"	6.41	4.61	7.85	4.84	2.13	8.99	0.89	VB015	14	4.2
3/4"	6.41	5.08	8.46	4.84	2.56	9.82	1.00	VB015	27	4.5
1"	6.41	5.59	8.48	4.84	2.87	10.02	1.13	VB015	53.9	5.8
1-1/4"	6.41	6.38	9.39	4.84	3.39	11.20	1.26	VB015	77	6.3
1-1/2"	6.41	6.77	9.66	4.84	3.86	11.71	1.38	VB015	123	7.1
2"	7.48	7.83	11.89	6.18	4.80	14.33	1.50	VB030	238	9.6
2-1/2"	8.42	9.25	13.15	7.28	6.46	16.58	1.75	VB060	368	14.0
3"	8.42	10.6	13.66	7.28	7.99	17.79	1.89	VB060	497	16.0
4"	9.33	12.13	15.04	8.30	9.37	20.12	2.26	VB110	665	32.0

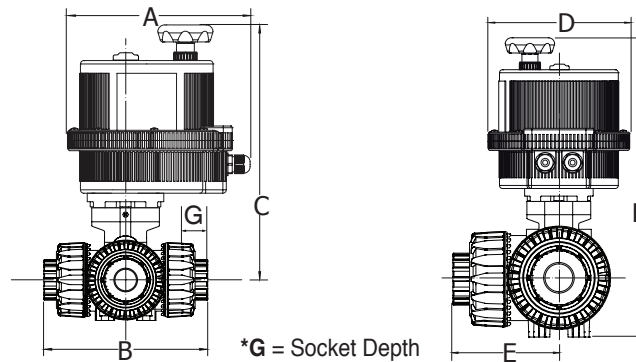

8E3LPVC 8E3TPVC

Size	A	B	C	D	E	F	G	Actuator	Wt.	Cv by Position		
										A	B	C
1/2"	6.41	5.20	7.85	4.84	2.60	8.99	0.89	VB015	6.5	4.55	43.7	5.11
3/4"	6.41	6.27	8.46	4.84	3.14	9.82	1.00	VB015	6.8	10.2	26.6	10.5
1"	6.41	6.85	8.48	4.84	3.43	10.02	1.13	VB015	7.1	17.2	53.2	18.6
1-1/4"	6.41	8.07	9.39	4.84	4.04	11.20	1.26	VB015	7.6	32.2	73.5	33.3
1-1/2"	7.48	8.96	11.49	6.18	4.48	11.71	1.38	VB030	7.6	42.0	119	43.4
2"	7.48	10.51	11.89	6.18	5.25	14.33	1.50	VB030	9.6	84.0	224	85.4

ON/OFF WIRING DIAGRAM - VB015

12V AC/DC, 24V AC/DC & 100-240VAC

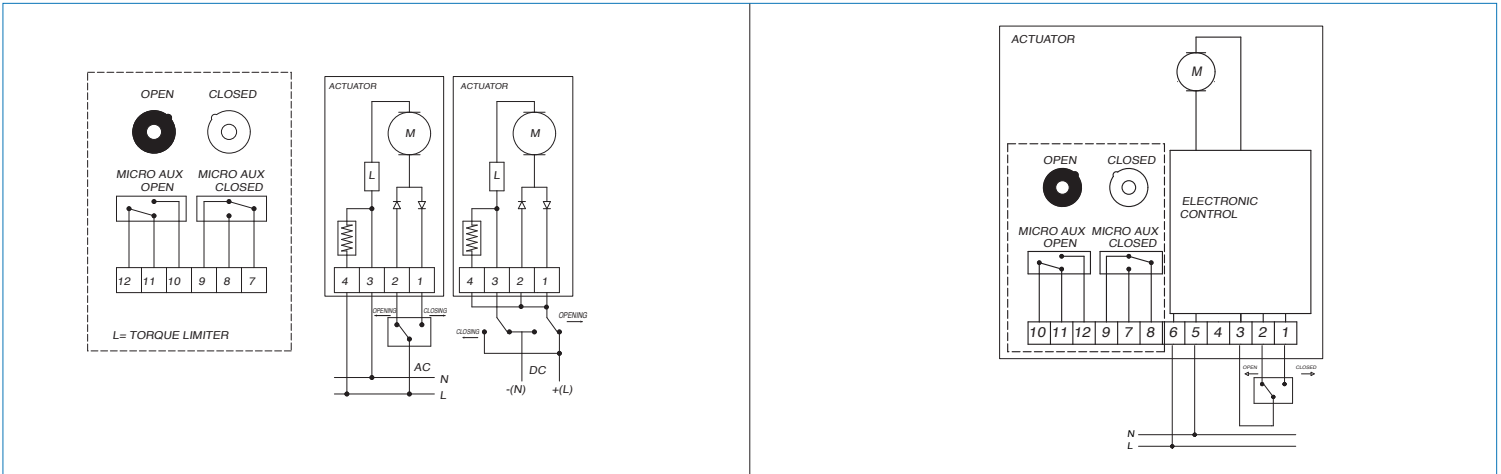

ON/OFF WIRING DIAGRAM - VB030

12V AC/DC, 24V AC/DC & 100-240VAC

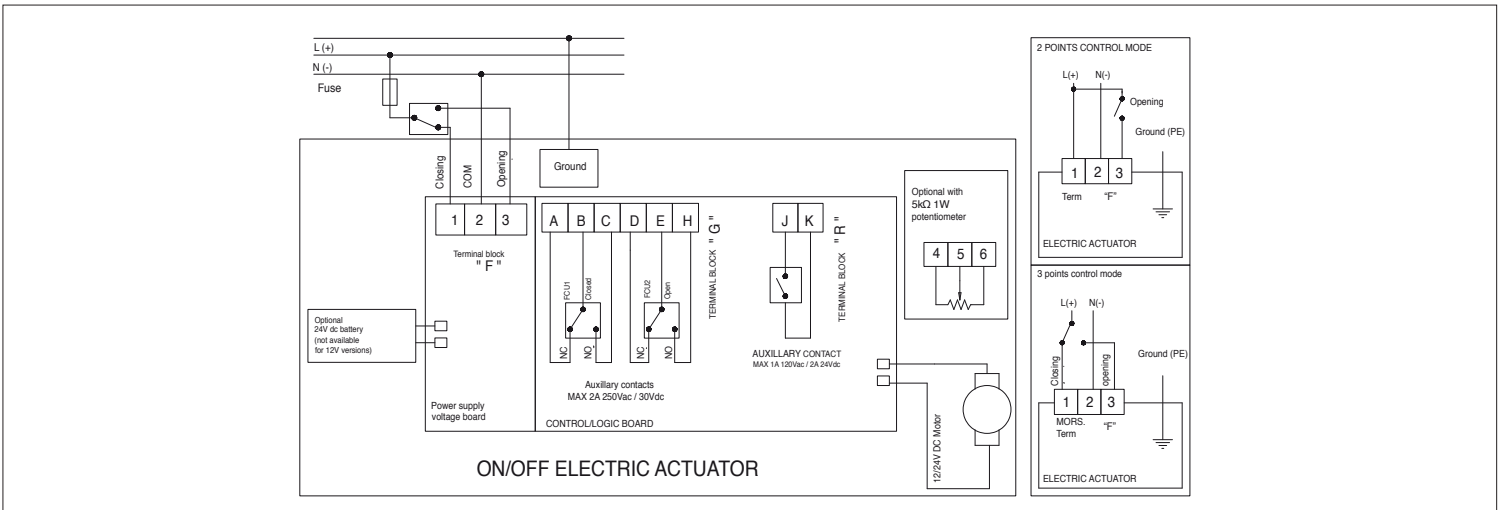

POSITIONER WIRING DIAGRAM - VB030

12V AC/DC, 24V AC/DC & 100-240VAC

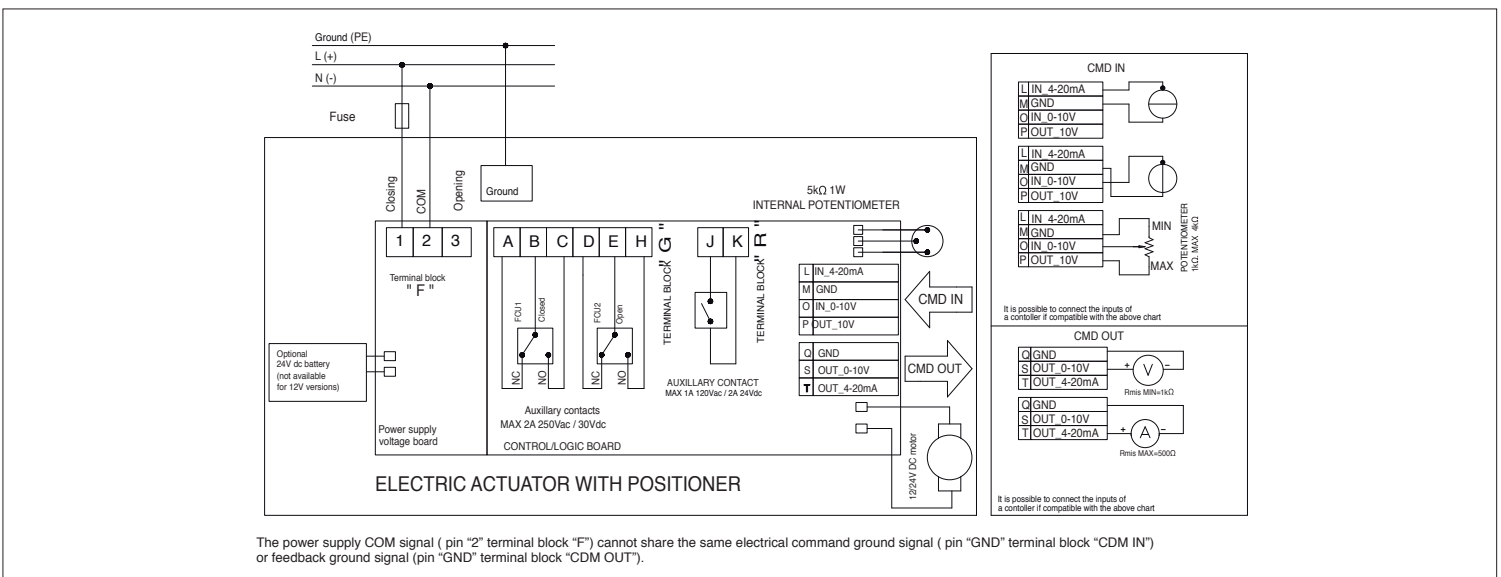

The power supply COM signal (pin "2" terminal block "F") cannot share the same electrical command ground signal (pin "GND" terminal block "CDM IN") or feedback ground signal (pin "GND" terminal block "CDM OUT").