

JOB NAME:	CONTRACTOR:
JOB LOCATION:	APPROVAL:
ENGINEER:	CONTRACTOR P.O.:
APPROVAL:	REPRESENTATIVE:

8P0124

600LL 2-WAY CARBON STEEL, FNPT THREADED BALL VALVE WITH W/ DOUBLE ACTING ACTUATOR

SIZES 1/4" TO 2"

8P0125

600LL 2-WAY CARBON STEEL, FNPT THREADED BALL VALVE WITH W/ SPRING RETURN ACTUATOR

SIZES 1/4" TO 2"

SPECIFICATIONS

The 8P0124-8P0125 series features an ASTM A216-WCB carbon steel, full port, 2000psi 1/4"-1", 1500psi 1 1/4"-2", with two-point mounting pad. The valve is also built to meet NACE MR-0175, and has ANSI B1.20.1 thread depths. A thermal relief hole in the ball stem slot is standard.

The Valbia pneumatic actuator comes with a hard-anodized aluminum body, and powder coated end caps. In addition, all Valbia pneumatic actuators are standardly furnished with elevated temperature seals to 302F. The patented side loaded limit stops never enter the piston chamber eliminating extra possible leak paths.

ACTUATOR FEATURES

- Hard anodized extruded aluminum body
- Concentric spring sets
- Die cast aluminum end caps
- Solid steel barstock pinion (not casting)
- 0°-90° rotation adjustment cam
- 0°-90° rotation adjustment bolts
- POM piston guides
- Minimum air pressure rating: 80 psi
- Maximum air pressure rating: 116 psi
- Working temperature: -4°F - 302°F
- No lubrication maintenance required for the entire actuator lifetime
- 100% factory tested

VALVE FEATURES

- 2-piece WCB body
- Full port, sizes 1/4" to 2"
- Self adjusting stem packing
- Blow out proof stem design
- 100% air tested under water at 80 psi
- Pressure rating 1/4" to 1" 2000 psi
- 1-1/4" to 2" 1000 psi - 150 psi steam
- Temperature range -4°F to 450°F
- Mounting pad for actuator
- Thermal relief hole in stem slot
- NACE MR-0175

PRESSURE - TEMPERATURE CHART FOR SERIES 600LL

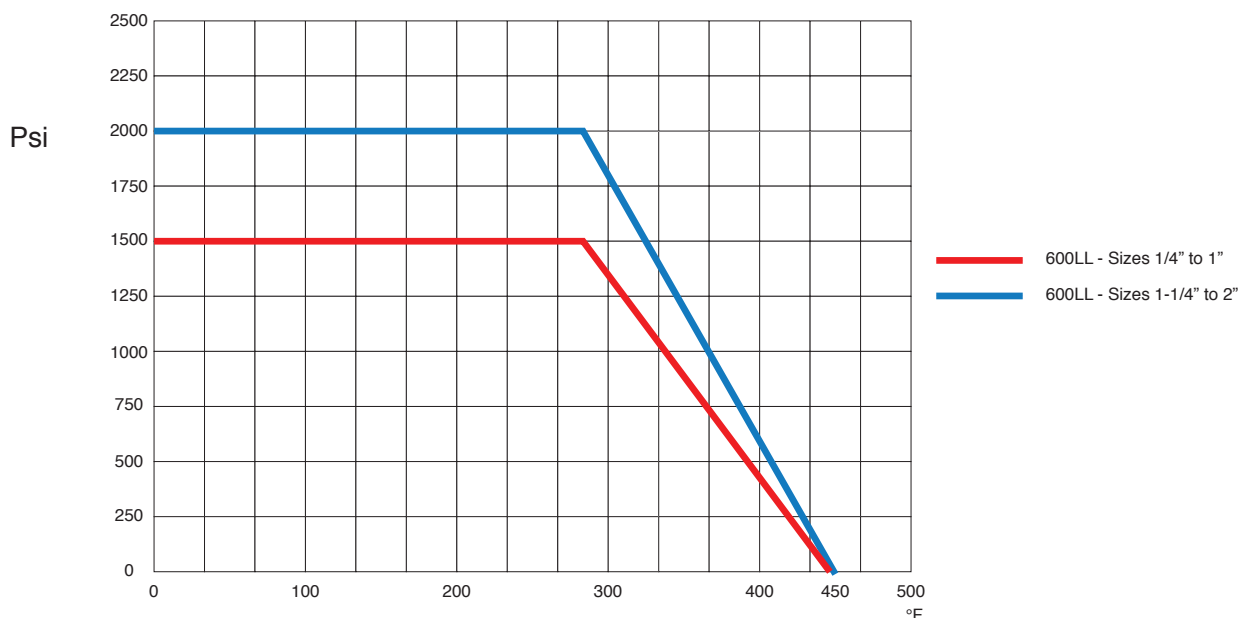

BILL OF MATERIALS FOR 600LL

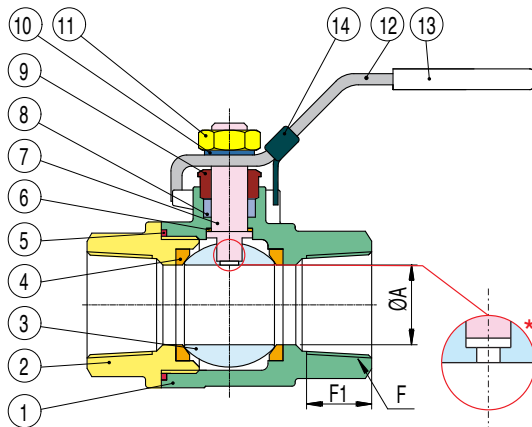

* THERMAL RELIEF HOLE IN THE STEM SLOT.

N POS	PART NAME	MATERIAL	N PCS
1	BODY	WCB	1
2	END CAP	WCB	1
3	BALL	AISI 316	1
4	SEAT	R.P.T.F.E.	2
5	JOIN GASKET	P.T.F.E.	2
6	THRUST WASHER	P.T.F.E.	1
7	STEM	AISI 316	1
8	V RING PACKING	P.T.F.E.	1
9	GLAND BUSH	STEEL	1
10	STEM WASHER	STEEL	1
11	STEM NUT	STEEL	1
12	HANDLE	STEEL	1
13	HANDLE SLEEVE	VINYL	1
14	LOCKING DEVICE	SS304	1

DIMENSIONS

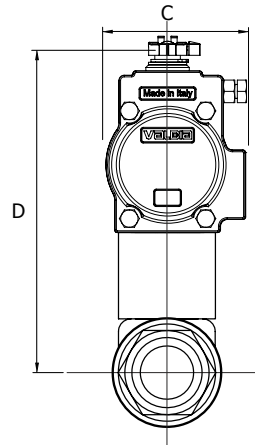
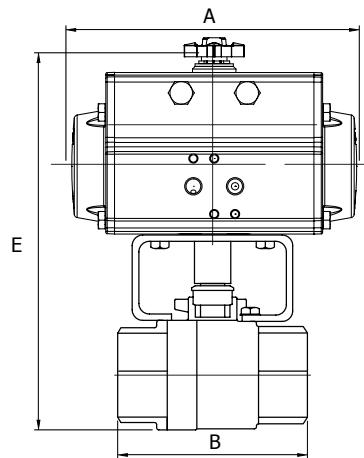

8P0124

600LL W/ **DOUBLE ACTING** ACTUATOR

Size	A	B	C	D	E	ACT. DA
1/4"	4.33	2.16	1.77	6.55	7.46	32
3/8"	4.33	2.16	1.77	6.55	7.75	32
1/2"	4.33	2.55	1.77	6.96	7.57	32
3/4"	4.33	2.93	1.77	7.10	7.85	32
1"	5.55	3.46	2.80	7.03	8.05	52
1-1/4"	5.55	4.01	2.80	7.06	8.31	52
1-1/2"	6.46	4.33	3.17	7.84	9.34	63
2"	8.27	4.92	3.72	8.79	10.79	75

8P0125

600LL W/ **SPRING RETURN** ACTUATOR

Size	A	B	C	D	E	ACT. SR
1/4"	5.55	2.16	2.80	6.39	6.89	52
3/8"	5.55	2.16	2.80	6.39	6.89	52
1/2"	5.55	2.55	2.80	6.80	6.89	52
3/4"	6.46	2.93	3.17	7.27	8.02	63
1"	8.27	3.46	3.72	8.20	9.21	75
1-1/4"	8.27	4.01	3.72	8.14	9.44	75
1-1/2"	9.47	4.33	4.17	9.10	10.60	85
2"	10.83	4.92	4.84	10.40	12.36	100