



NSF/ANSI  
61, 372

JOB NAME:	CONTRACTOR:
JOB LOCATION:	APPROVAL:
ENGINEER:	CONTRACTOR P.O.:
APPROVAL:	REPRESENTATIVE:

## EN501N

RUBBER-LINED DIRECT MOUNT, LUG STYLE BUTTERFLY VALVE WITH EPDM SEATS AND NYLON DISC WITH VALBIA ELECTRIC ACTUATOR

SIZES 2" TO 12"

E531N - VITON SEATS

## EN501S

RUBBER-LINED DIRECT MOUNT, LUG STYLE BUTTERFLY VALVE WITH EPDM SEATS AND STAINLESS STEEL DISC WITH VALBIA ELECTRIC ACTUATOR

SIZES 1-1/2" TO 12"

E531S - VITON SEATS

E541S - BUNA SEATS

*001	12V AC/DC	*002	24V AC/DC	*003	100-240V AC
*01*	BATTERY BACKUP	*02*	POSITIONER	*04*	BATTERY BACKUP W POSITIONER

## SPECIFICATIONS

Bonomi North America series EN501N and EN501S, ductile iron lug style, epoxy coated, resilient seat butterfly valves in sizes 1-1/2"-12", with EPDM seat are NSF/ANSI 61/372 certified.

This series shall offer a dual stem design and ISO 5211/DIN 3337 direct mounting for high cycle automation capabilities.

In addition, the EN501N-EN501S series features a phenolic-backed cartridge seat design which offers a 250 CWP maximum pressure rating, dead-end service to 100 PSI, and conforms to ANSI B16.1 and ANSI B16.5

The EN501 Series includes an electric actuator with a high-strength, weather-proof technopolymer housing with a heater and thermostat included. The NEMA 4, 4X housing is resistant to dusty areas, and in areas where water may be sprayed.

## ACTUATOR FEATURES

- NEMA 4, 4X IP67 Housing
- Dual Voltage motors
- ISO 5211 dual patterns
- 75% Duty Cycle
- High-Strength, Impact Resistant IP67 Technopolymer Housing
- Temperature Range -4°F to 131°F
- PG11 Electrical Connection/Optional 1/2" Conduit

## VALVE FEATURES

- ISO 5211 Direct Mount /Square Stem
- Epoxy coated Ductile Iron Lug body
- EPDM resilient seat (-30°F TO 250°F)
- 531N/531S - VITON seats (10°F TO 300°F)
- 541S - BUNA seats (10°F TO 250°F)
- API609 face to face flange
- Floating dual shaft disc design
- MSS SP 67 compliant
- No pins in disc prevent potential leak points
- NSF/ANSI 61, 372 approved

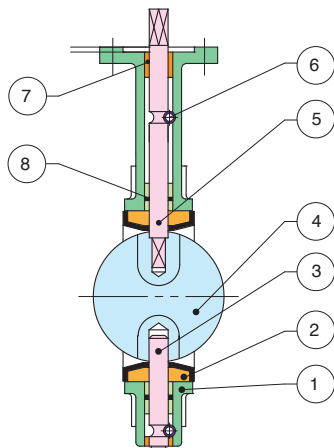

## BILL OF MATERIALS

N POS	PART NAME	MODEL	MATERIAL	N PCS
1	BODY		CAST IRON	1
2	SEAT	N501N/N501S	EPDM (-30°F TO 250°F)	1
		531N/531S	VITON (10°F TO 300°F)	
		541S	BUNA (10°F TO 250°F)	
3	LOWER SHAFT		SS416	1
4	DISC 501N		CAST IRON / NYLON 11 COATED	1
	DISC 501S		STAINLESS STEEL	
5	UPPER SHAFT		SS416	1
6	LOCATING PIN		CARBON STEEL	1
7	BUSHING		P.T.F.E.	1
8	O-RING		EPDM	1
9	LEVER		EPOXY-COATED CARBON STEEL	1

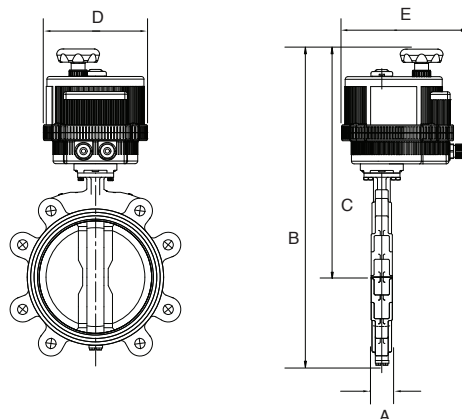

Note: EPDM Seats Std. Other Seating Material Available

## DIMENSIONS

Size		1-1/2" *	2"	2-1/2"	3"	4"	5"	6"	8"	10"	12" **
<b>A</b>		1.30	1.69	1.81	1.81	2.05	2.20	2.20	2.36	2.58	3.03
<b>B</b>		13.18	14.09	14.56	14.84	15.59	16.22	17.41	18.59	28.68	31.99
<b>C</b>		11.43	11.61	11.96	12.2	12.95	13.46	14.61	16.03	20.69	22.46
<b>D</b>		7.28	7.28	7.28	7.28	7.28	7.28	8.31	8.31	8.74	8.74
<b>E</b>		8.43	8.43	8.43	8.43	8.43	8.43	9.33	9.33	9.72	9.72
<b>Seat Torque</b>	100 psi	111	126	134	205	339	523	677	1205	1890	2808
	200 psi	133	146	167	223	386	602	996	1864	3140	4767
<b>Cv (GPM @1psi)</b>	50% OP	35	45	65	70	140	235	360	715	1225	1900
	100% OP	108	135	220	300	605	1010	1620	3205	5305	8250
<b>Act.</b>		VB030	VB030	VB030	VB030	VB060	VB110	VB190	VB270	VB350	VB350

\* 1-1/2" available in Stainless Steel Disc only \*\* - Liquid Service = 100 psi Maximum

## ON/OFF WIRING DIAGRAM

12V AC/DC, 24V AC/DC & 100-240VAC

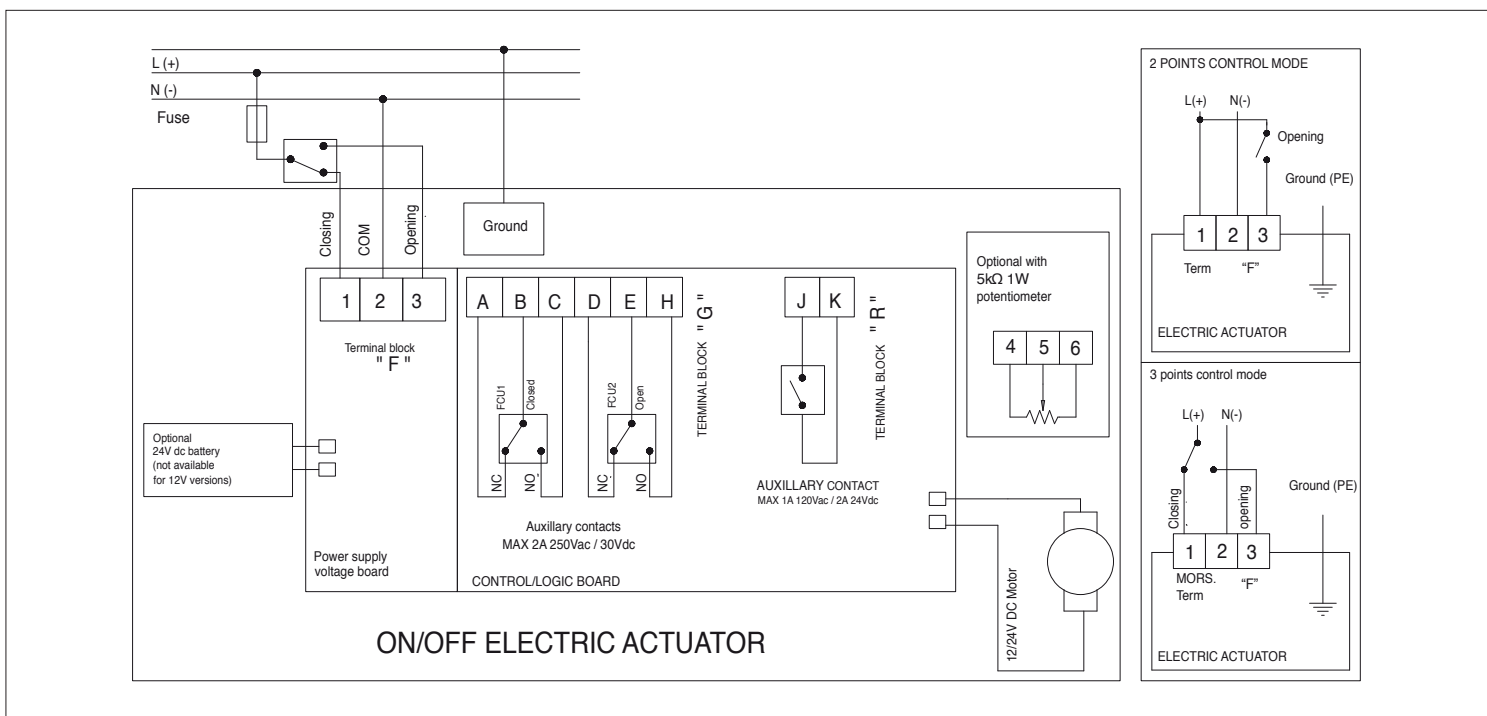

# POSITIONER WIRING DIAGRAM

12V AC/DC, 24V AC/DC & 100-240VAC

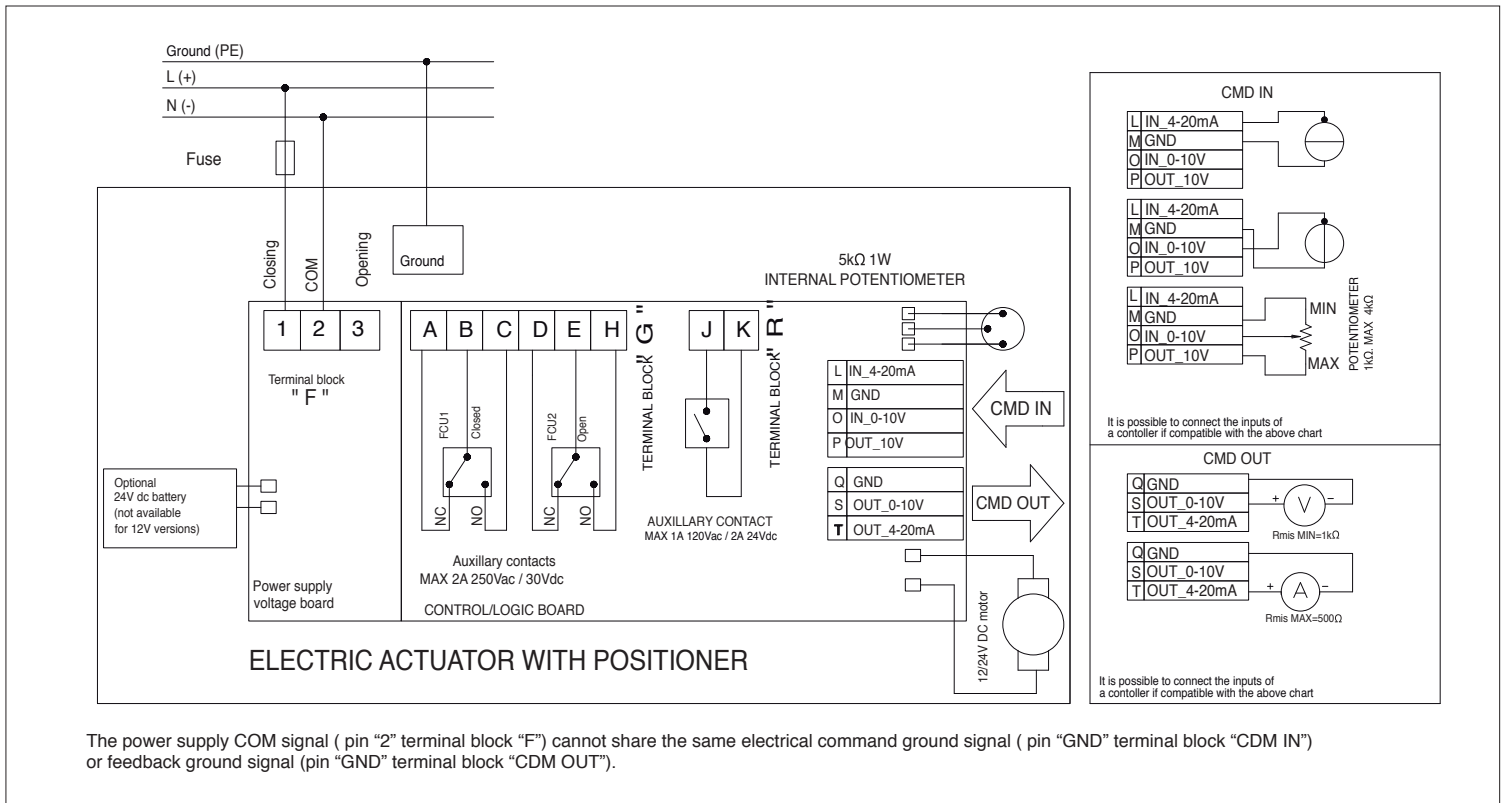

# 3-POSITION WIRING DIAGRAM - 3-WAY VALVES ONLY

12V AC/DC, 24V AC/DC & 100-240VAC

