



JOB NAME:	CONTRACTOR:
JOB LOCATION:	APPROVAL:
ENGINEER:	CONTRACTOR P.O.:
APPROVAL:	REPRESENTATIVE:

M8E0630-00* - M8E0631-00* - M8E0632-00*
FNPT THREADED SOCKET WELD BUTT WELD

630LL DIRECT MOUNT, 3-PC, 2-WAY CARBON STEEL, CLASS 900 FULL PORT BALL VALVE IN NPT, SW OR BUTT WELD W/VALBIA METAL ELECTRIC ACTUATOR SIZES 1/4" TO 4"

*001 12V AC/DC	*002 24V AC/DC	*003 100-240V AC
01 BATTERY BACKUP	*02* POSITIONER	*04* BATTERY BACKUP W POSITIONER

SPECIFICATIONS

The M8E0630/M8E0631/M8E0632 series packages feature a carbon steel high performance three-piece full port, encapsulated bolt style, Class 900 [1/4"-2", Class 600 2 1/2"-4"] ball valve. The valve also incorporates an ISO 5211 direct mount pad with square stem. Further, the valve has high temperature TFM-4215 seats, conforms to ANSI 16.34, ANSI B1.20.1 Thread depths, NACE MRO 175, latch locking handle and an API 607 6th edition fire safe option. The Valbia VBM electric actuator has a rugged NEMA 4 die cast aluminum housing and features a raised or dome position indicator. In addition, the VBM series also incorporates dual voltage motors, two extra limit switches, a heater and thermostat, manual override, 1/2" conduit connections and a 75% duty cycle motor.

ACTUATOR FEATURES

- Dual Voltages
- 24V AC/DC and 100-240V AC Models Available
- ISO 5211 Dual Patterns
- 75% Duty Cycle
- Anti-condensation heater, (when red wire is connected to power)
- High-Strength, Die Cast Aluminum Powder Coated Housing
- Temperature Range -4°F to 131°F
- NEMA 4 Housing
- Two Auxiliary Switches Standard
- Torque limiter standard
- 1/2" conduit connections

VALVE FEATURES

- 3-piece WCB body
- Class 900 sizes 1/4" to 2", Class 600 sizes 2-1/2" to 4"
- Carbon steel-2220 psi (1/4" to 2"), 1500 psi (2-1/2" to 4")
- ISO 5211 mounting pad w/ square stem
- TFM-4215 ball seats
- Standard latch locking handle
- Conforms to ANSI 16.34, ANSI B1.20.1 thread depths, NACE MR0175
- Fire Safe to API 607-6th edition
- Grounded ball and stem
- Standard 316 stainless steel ball and stem
- Temperature range: -50° F to 550° F

BILL OF MATERIALS FOR 630LL / 631LL / 632LL

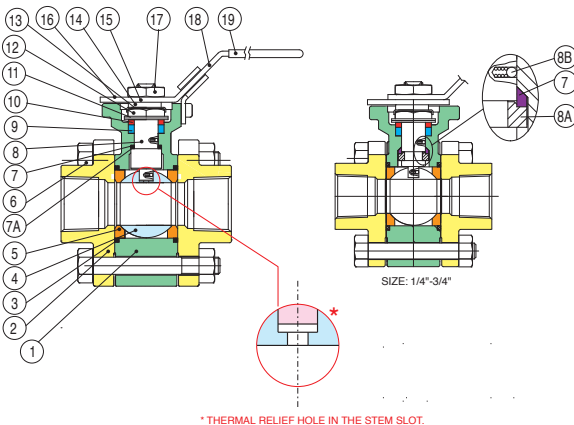

N POS	PART NAME	MATERIAL	N POS
1	BODY	WCB	1
2	END CAP	WCB	2
3	GASKET BODY	TFM	2
4	BALL	SS316	1
5	BALL SEATS	TFM-4215	2
6	BOLTS	SS304	*
7	THRUST WASHER	TFM	1
7A	THRUST WASHER	PEEK	1
8	STEM	SS316	1
8A	HALF SPLIT RING	SS316	1
8B	ANTI-STATIC	SS316	2

N POS	PART NAME	MATERIAL	N POS
9	STEM PACKING	TFM	1
10	GLAND WASHER	SS304	1
11	DISK WASHER	SS301	1
12	STEM NUT	SS304	1
13	NUT STOP	SS304	1
14	SPACE WASHER	SS304	1
15	PLATER	SS304	1
16	STOP IN	SS304	1
17	HANDLE NUT	SS304	1
18	HANDLE	SS304	1
19	HANDLE COVER	PLASTISOL	1

*VARIES WITH SIZE

VB030M-VB190M

SIZES 1/4" THROUGH 4"

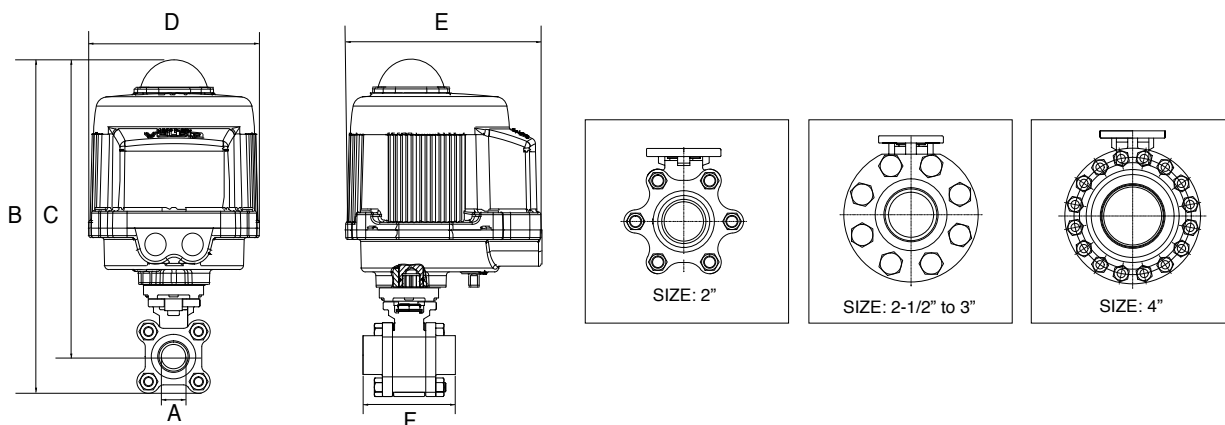

DIMENSIONS

Size	A	B	C	D	E	F	ACT.
1/4"	.250	10.64	9.64	6.34	7.36	2.62	VB030M
3/8"	.375	10.64	9.64	6.34	7.36	2.62	VB030M
1/2"	.500	10.76	9.72	6.34	7.36	2.76	VB030M
3/4"	.750	11.07	9.92	6.34	7.36	3.62	VB030M
1"	1.00	11.43	10.15	6.34	7.36	4.14	VB030M
1-1/4"	1.25	12.45	11.10	6.93	7.76	4.37	VB060M
1-1/2"	1.50	12.93	11.42	6.93	7.76	4.89	VB060M
2"	2.00	15.18	13.23	6.93	7.76	5.91	VB060M
2-1/2"	2.50	16.09	13.82	10.63	10.63	6.50	VB110M
3"	3.00	16.95	14.37	10.63	10.63	7.68	VB110M
4"	4.00	18.47	15.35	10.63	10.63	9.65	VB190M

ON/OFF WIRING DIAGRAM

12V AC/DC, 24V AC/DC & 100-240VAC

