

## SERIES 500N - 500S

NYLON 11 COATED DISC    CF8M SS DISC

- Manually operated butterfly valves.
- Epoxy coated cast iron wafer body.
  - Full port sizes 1"1/2 to 12".
  - EPDM resilient seat -30°F to 250°F.
  - API609 face to face flange.
  - Floating dual shaft disc design.
  - 10 position stop.
  - MSS SP 67 compliant.
  - No pins in disc prevent potential leak points.

530N-530S: VITON SEATS

540N-540S: BUNA-N SEATS

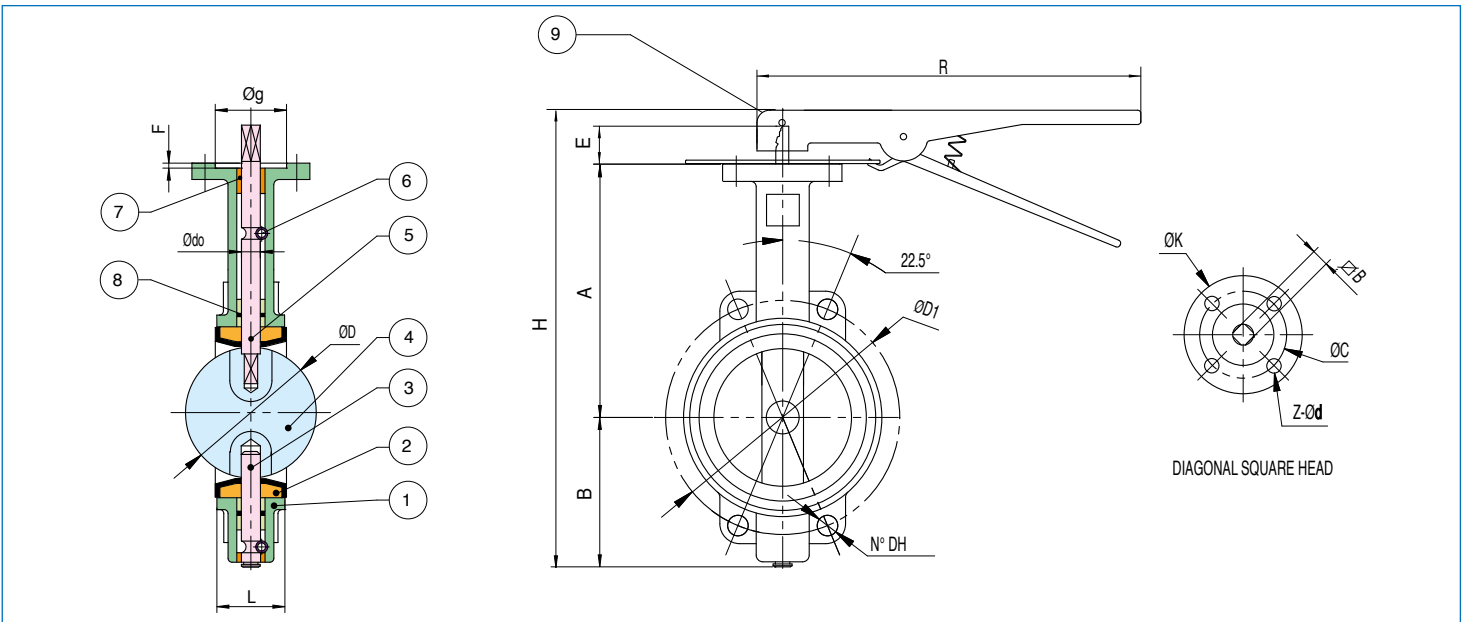

N° PCS	PART NAME	MATERIAL	N° PCS	SIZE	ØC ISO	Z-B	A	B	L	ØD	E	H	R	Ødo	UPPER FLANGE				DISC	WAFER	WT.	SEAT TORQUE		CV (GPM@ 1psi)	
															ØK	Z-d	Øg	F				ØD1	N°-DH	Lbs	100 psi
1	BODY	CAST IRON	1	1"1/2	F05	9 mm	5.71	2.97	1.61	1.67	0.47	12.95	10.63	0.50	3.03	4-0.28	1.38	0.12	4.74	4-0.75	5.0	111	133	35	108
2	SEAT	EPDM (30F to 250F)	1	2"	F05	9 mm	6.34	3.15	1.65	2.07	0.47	13.94	10.63	0.50	3.03	4-0.28	1.38	0.12	4.74	4-0.75	5.5	126	146	45	135
3	LOWER SHAFT	SS 416	1	2"1/2	F05	9 mm	6.89	3.50	1.76	2.54	0.47	15.04	10.63	0.50	3.03	4-0.28	1.38	0.12	5.49	4-0.75	7.1	134	167	65	220
4	DISC 500N DISC 500S	IRON NYLON 11 STAINLESS STEEL	1	3"	F05	9 mm	7.13	3.74	1.78	3.10	0.47	15.51	10.63	0.50	3.03	4-0.28	1.38	0.12	6.00	4-0.75	8.4	205	223	70	300
5	UPPER SHAFT	SS 416	1	4"	F07	11 mm	7.87	4.49	2.05	4.09	0.63	17	10.63	0.62	3.54	4-0.35	2.17	0.12	7.50	4-0.75	10.8	339	386	140	605
6	LOCATING PIN	CARBON STEEL	1	5"	F07	14 mm	8.34	5.00	2.14	4.85	0.75	17.94	10.63	0.75	3.54	4-0.35	2.17	0.12	8.50	4-0.87	15.4	523	602	235	1010
7	BUSHING	P.T.F.E.	1	6"	F07	14 mm	8.90	5.47	2.20	6.13	0.75	19.06	10.63	0.75	3.54	4-0.35	2.17	0.12	9.50	4-0.87	17.2	677	996	360	1620
8	O-RING	EPDM	1	8"	F10	17 mm	10.24	6.89	2.34	7.97	0.75	22.25	14.17	0.87	4.92	4-0.47	2.76	0.14	11.75	4-0.87	29.1	1205	1864	715	3205
9	LEVER	EPOXY-COATED CARBON STEEL	1	10"*	F10	22 mm	11.50	7.99	2.58	9.86	0.94	24.77	19.68	1.12	4.92	4-0.47	2.76	1.40	14.25	4-1.00	42.2	1890	3140	1225	5305
				12"*	F10	22 mm	13.27	9.53	3.03	11.87	0.94	28.31	19.68	1.24	5.51	4-0.47	2.76	1.40	17.00	4-1.00	71.5	2808	4767	1900	8250

\* 10" and 12" available in bare stem version only.



Type 4X Indoor Use Only Enclosure.

**DESIGN PROTECTED**

## GENERAL SPECIFICATIONS

The VALBIA electric actuators are suitable for the automation of ball and butterfly valves for the industrial and construction sector. The usage of electronic components of last generation, together with precise mechanic, thanks to a careful research and development, enables high performance and long-term reliability of the product.

The range has been manufactured with following characteristics:

- The housing of the actuators provides a V0 self-extinguish class techno-polymer material.
- The kinematics is made by steel and techno-polymer gear wheels, sustained by hardened steel pinions, mounted on self-lubricating bushes and inserted in a strong structure of die-cast aluminium (excluding mod. VB015).
- The connection part of the actuators with the valves, is made by a die-casted and painted aluminium plate cataphoresis, with a dual drilling interface as per the ISO5211-DIN 3337 Standard.
- The electronic circuit adjusts automatically the motor speed depending on the mechanical load variations in order to drive the cycle always in the same time.
- The whole range of actuators is provided with an electronic safety system for the torque control (torque limiter).
- The whole range of actuators is standard provided of heater activated with the powered actuator.
- The whole range of actuators (except for mod. VB015) is modulable: and programmable in standard mode (4-20 mA or 0-10V) or reverse mode (20-4 mA or 10-0V)
- All electric actuators (except for mod. VB015) can be equipped with rotary potentiometer (5K $\Omega$  1W).
- All electric actuators (except for mod. VB015 and for 12V power supply), can be equipped with battery backup for emergency control.

MODEL		VB015	VB030	VB060	VB110	VB190	VB270	VB350
MAX WORKING TORQUE (IN-LBS)		133	266	530	975	1680	2390	3100
VOLTAGE (V)	LOW VOLTAGE	12V AC/DC	12V AC/DC	12V AC/DC	12V AC/DC	12V AC/DC	12V AC/DC	12V AC/DC
		24V AC/DC	24V AC/DC	24V AC/DC	24V AC/DC	24V AC/DC	24V AC/DC	24V AC/DC
	MULTIVOLTAGE	100-240V AC	100-240V AC	100-240V AC	100-240V AC	100-240V AC	100-240V AC	100-240V AC
WORKING TIME (sec)		10	8	9	27	27	50	50
TORQUE LIMITER		STD	STD	STD	STD	STD	STD	STD
DUTY RATING		12VAC/24VAC 50% 12VDC/24VDC 75% 100-240VAC	12VAC/DC 50% 24VAC/DC 75% 100-240VAC	12VAC/DC 50% 24VAC/DC 75% 100-240VAC	12VAC/DC 50% 24VAC/DC 75% 100-240VAC	12VAC/DC 50% 24VAC/DC 75% 100-240VAC	12VAC/DC 50% 24VAC/DC 75% 100-240VAC	12VAC/DC 50% 24VAC/DC 75% 100-240VAC
PROTECTION		IP65	IP67	IP67	IP67	IP67	IP67	IP67
ROTATION		90°	90°	90°	90°	90°	90°	90°
UPON REQUEST		180°	180° or 270°	180° or 270°	180° or 270°	180° or 270°	180° or 270°	180° or 270°
MANUAL OVERRIDE		STD	STD	STD	STD	STD	STD	STD
POSITION INDICATOR		STD	STD	STD	STD	STD	STD	STD
WORKING TEMPERATURE		-4°F + 131°F	-4°F + 131°F	-4°F + 131°F	-4°F + 131°F	-4°F + 131°F	-4°F + 131°F	-4°F + 131°F
HEATER		STD	STD	STD	STD	STD	STD	STD
ADDITIONAL FREE LIMIT SWITCHES		n°2 STD (type SPDT)	n°2 STD (type SPDT)	n°2 STD (type SPDT)	n°2 STD (type SPDT)	n°2 STD (type SPDT)	n°2 STD (type SPDT)	n°2 STD (type SPDT)
DRILLING ISO 5211		*F03 - F05	*F03 - F05	F05 - F07	F07 - F10	F07 - F10	F07 - F10	F07 - F10
SQUARE (in)		0.43	0.43	0.55	0.67	0.67	0.87	0.87
SQUARE UPON REQUEST		0.35	0.35-0.55	0.43-0.67	0.55-0.87	0.55-0.87	0.67	0.67
FAIL-SAFE OPERATION (BATTERY BACKUP)		NOT AVAILABLE	UPON REQUEST	UPON REQUEST	UPON REQUEST	UPON REQUEST	UPON REQUEST	UPON REQUEST
		NOT AVAILABLE FOR MOD. 12V						
POSITIONER STD (4~20mA or 0~10 VDC) REVERSE (20~4mA or 10~0 VDC)		NOT AVAILABLE	UPON REQUEST	UPON REQUEST	UPON REQUEST	UPON REQUEST	UPON REQUEST	UPON REQUEST
LINEAR POTENTIOMETER (5K Ω 1W)		NOT AVAILABLE	UPON REQUEST	UPON REQUEST	UPON REQUEST	UPON REQUEST	UPON REQUEST	UPON REQUEST
ELECTRICAL CONNECTIONS		PG11	PG11	PG11	PG11	PG11	PG11	PG11
WEIGHT (LBS)		3.09	5.07	7.28	10.80	10.80	13.23	13.23

\* F04 or F07 upon request.

POWER CONSUMPTION															
MODEL		VB015		VB030		VB060		VB110		VB190		VB270		VB350	
VERSION H	NOMINAL VOLTAGE	100-240V AC													
	ABSORBED CURRENT	0.3-0.19 A		0.4-0.2 A		0.6-0.3 A		0.4-0.2 A		0.6-0.3 A		0.6-0.3 A		0.75-0.4 A	
	ABSORBED POWER	30-46 VA		40-48 VA		60-72 VA		40-48 VA		60-72 VA		60-72 VA		75-96 VA	
VERSION L	NOMINAL VOLTAGE	12V AC/DC	24V AC/DC	12V AC/DC	24V AC/DC	12V AC/DC	24V AC/DC	12V AC/DC	24V AC/DC	12V AC/DC	24V AC/DC	12V AC/DC	24V AC/DC	12V AC/DC	24V AC/DC
	ABSORBED CURRENT	1.2 A	0.6 A	2.2-1.8 A	1-0.7 A	3.8-2.85 A	1.8-1.2 A	2.2-1.8 A	1-0.7 A	3.8-2.85 A	1.8-1.2 A	3.8-2.85 A	1.8-1.2 A	4.75-3.65 A	1.95-1.65 A
	ABSORBED POWER	15 VA		26.5-22 VA	24-17 VA	46-34 VA	43-29 VA	26.5-22 VA	24-17 VA	46-34 VA	43-29 VA	46-34 VA	43-29 VA	57-44 VA	47-40 VA
FREQUENCY		50/60 HZ													



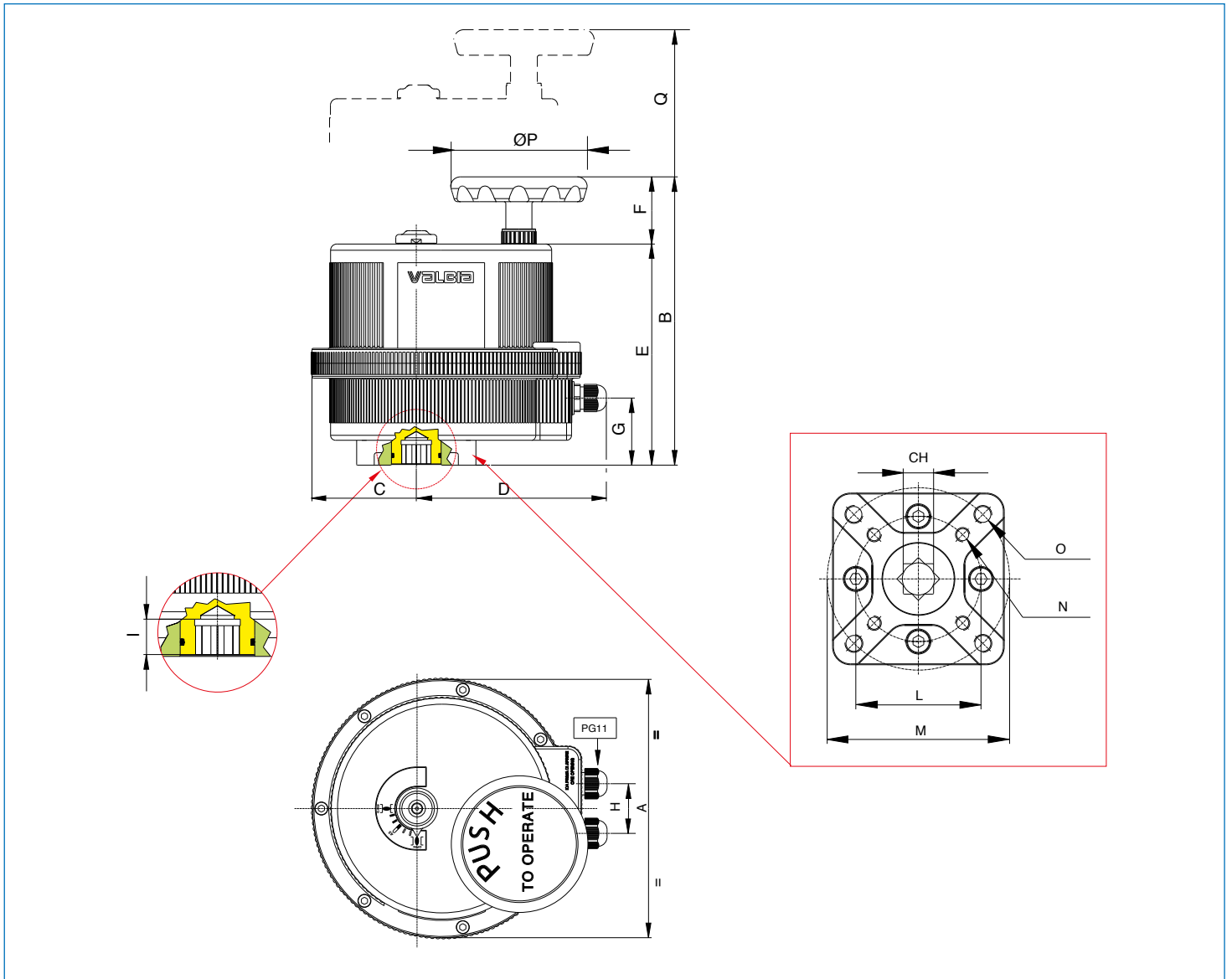

MOD.	DRILLING ISO 5211	CH	A	B	C	D	E	F	G	H	I	L	M	N	O	ØP	Q
VB015	F03 - F05 *	0.43	4.84	5.57	1.67	4.74	4.96	0.61	4.06	1.26	0.55	1.42	1.97	10-24 UNC 2BX0.47	1/4-20 UNC 2BX0.51	2.68	2.56
VB030	F03 - F05 *	0.43	6.18	7.40	2.38	5.10	5.75	1.65	1.30	1.42	0.47	1.42	1.97	10-24 UNC 2BX0.47	1/4-20 UNC 2BX0.51	2.56	3.94
VB060	F05 - F07	0.55	7.28	8.46	2.66	5.77	6.81	1.65	2.01	1.42	0.63	1.97	2.76	1/4-20 UNC 2BX0.59	5/16-18 UNC 2BX0.63	2.56	4.33
VB110	F07 - F10	0.67	8.31	9.14	3.31	6.02	7.01	2.13	2.13	1.58	0.75	2.76	4.02	5/16-18 UNC 2BX0.75	3/8-16 UNC 2BX0.75	4.33	4.53
VB190	F07 - F10	0.67	8.31	9.14	3.31	6.02	7.01	2.13	2.13	1.58	0.75	2.76	4.02	5/16-18 UNC 2BX0.75	3/8-16 UNC 2BX0.75	4.33	4.53
VB270	F07 - F10	0.87	8.74	9.19	3.03	6.69	7.17	2.03	2.13	1.58	0.95	2.76	4.02	5/16-18 UNC 2BX0.75	3/8-16 UNC 2BX0.75	4.33	4.53
VB350	F07 - F10	0.87	8.74	9.19	3.03	6.69	7.17	2.03	2.13	1.58	0.95	2.76	4.02	5/16-18 UNC 2BX0.79	3/8-16 UNC 2BX0.75	4.33	4.53

\* Upon request F04 or F07.

## ELECTRIC WIRING VB015 100–240V 50/60Hz

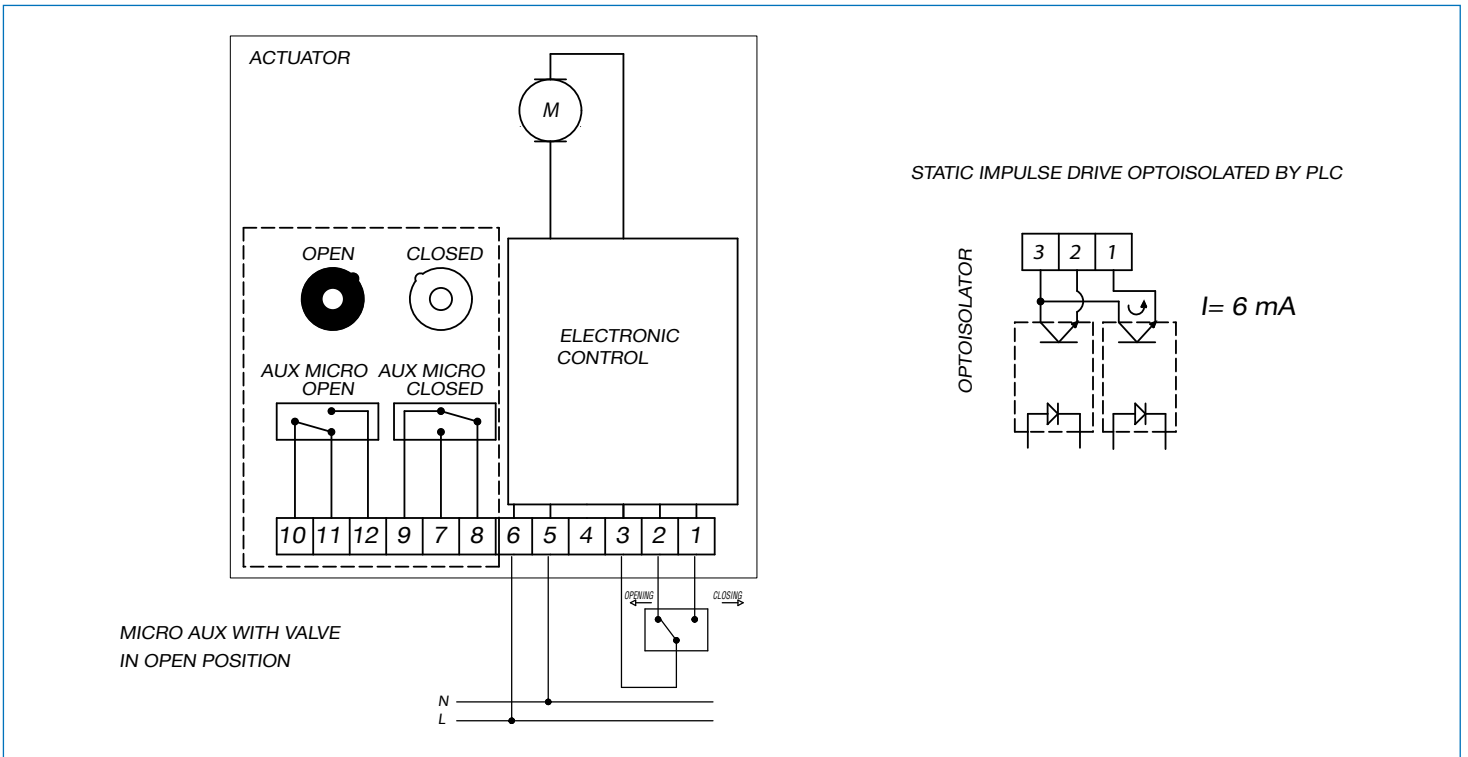

## ELECTRIC WIRING VB015 12V–24V AC/DC 50/60 Hz

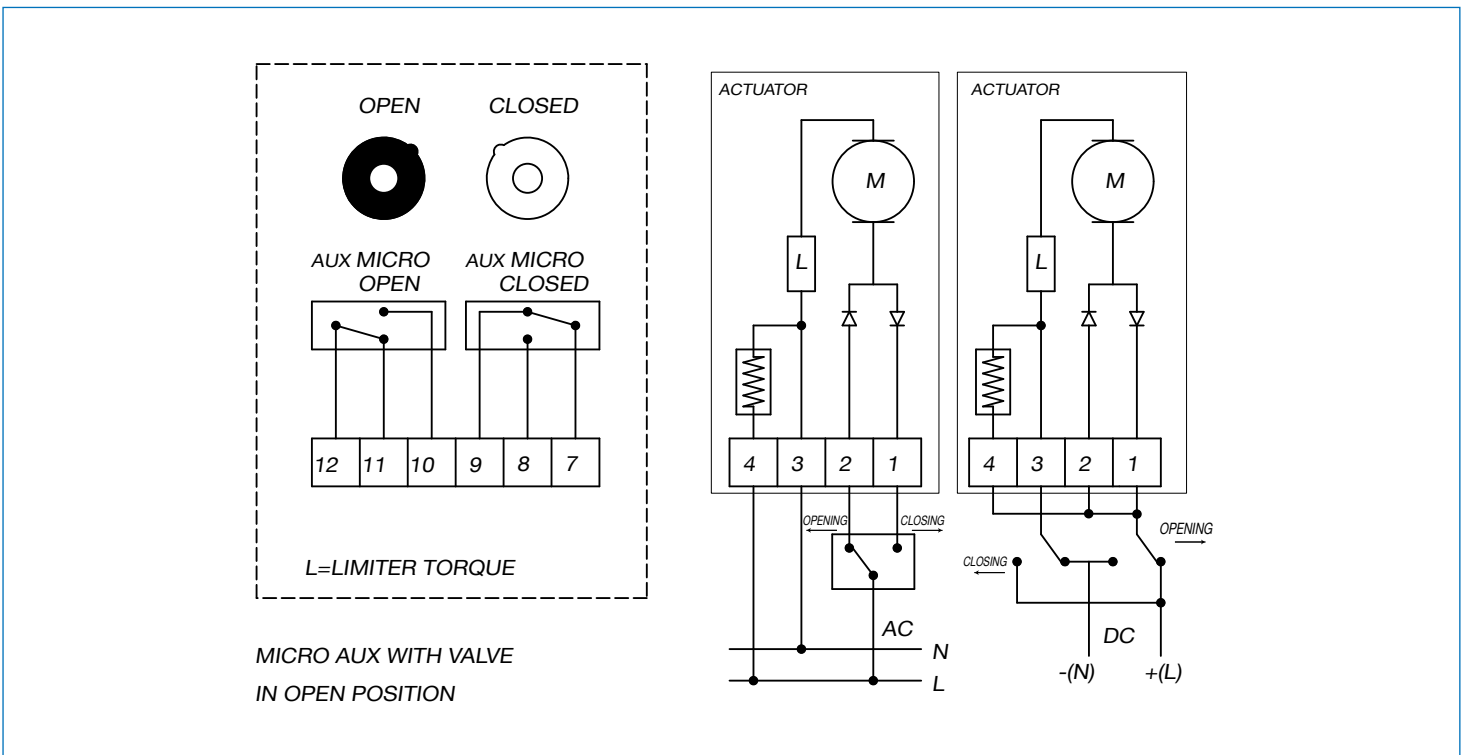

**ELECTRIC WIRING FROM VB030 TO VB350 12V AC/DC 50/60 Hz, 24V AC/DC 50/60 Hz, 100-240V AC 50/60 Hz**

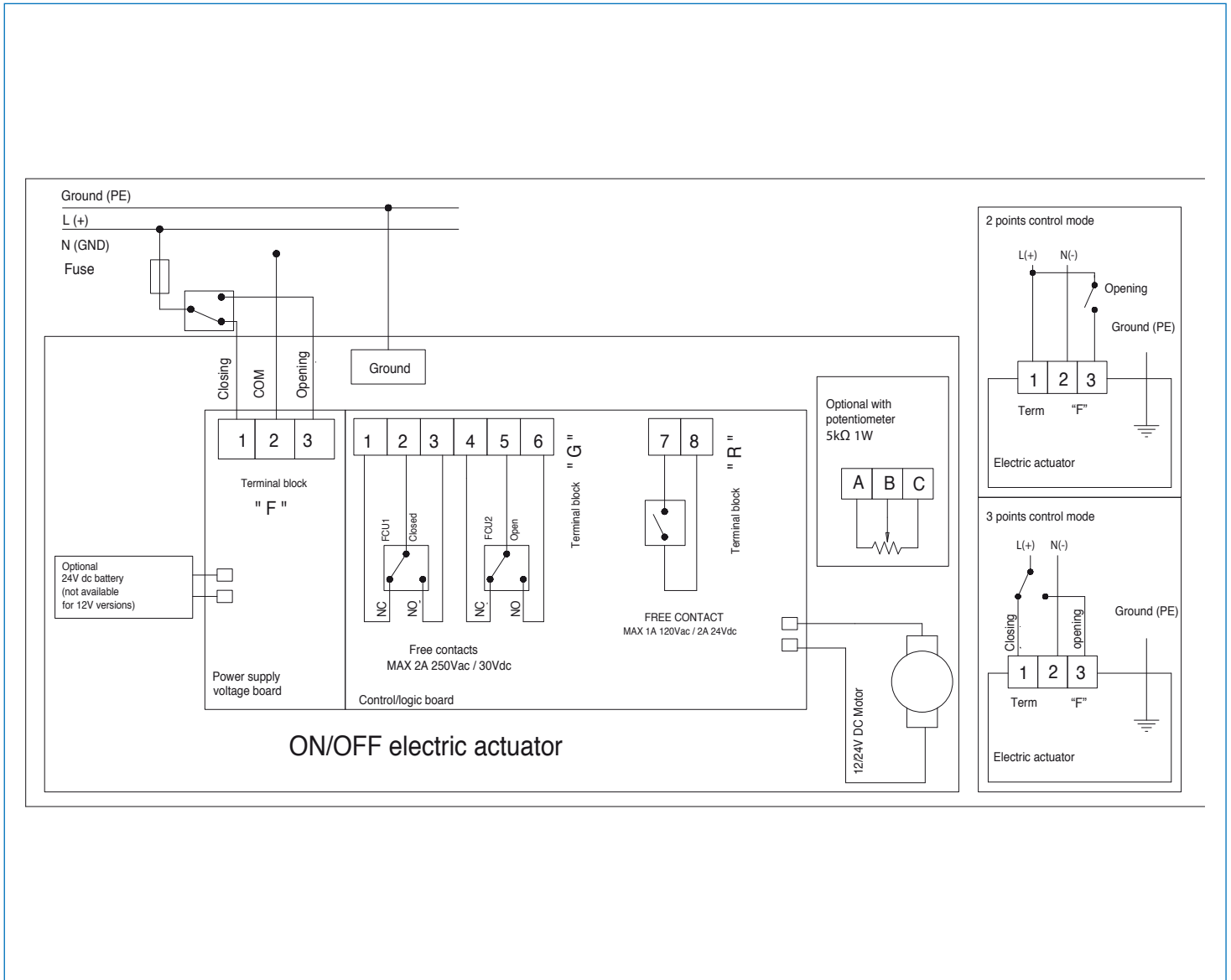

**ELECTRIC WIRING WITH POSITIONER FROM VB030 TO VB350 12V AC/DC 50/60 Hz, 24V AC/DC 50/60 Hz, 100-240V AC 50/60 Hz**

