

SERIES G500N - G500S

NYLON 11 COATED DISC CF8M SS DISC

- Gear operated butterfly valves.
- Epoxy coated cast iron wafer body.
 - Full port sizes 1"1/2 to 12".
 - Direct mount ISO 5211
 - EPDM resilient seat -30°F to 250° F.
 - Low turn ratio.
 - API609 face to face flange.
 - Floating dual shaft disc design.
 - IP54 enclosure.
 - MSS SP 67 compliant.
 - No pins in disc prevent potential leak points.

G530N-G530S: VITON SEATS
G540N-G540S: BUNA-N SEATS

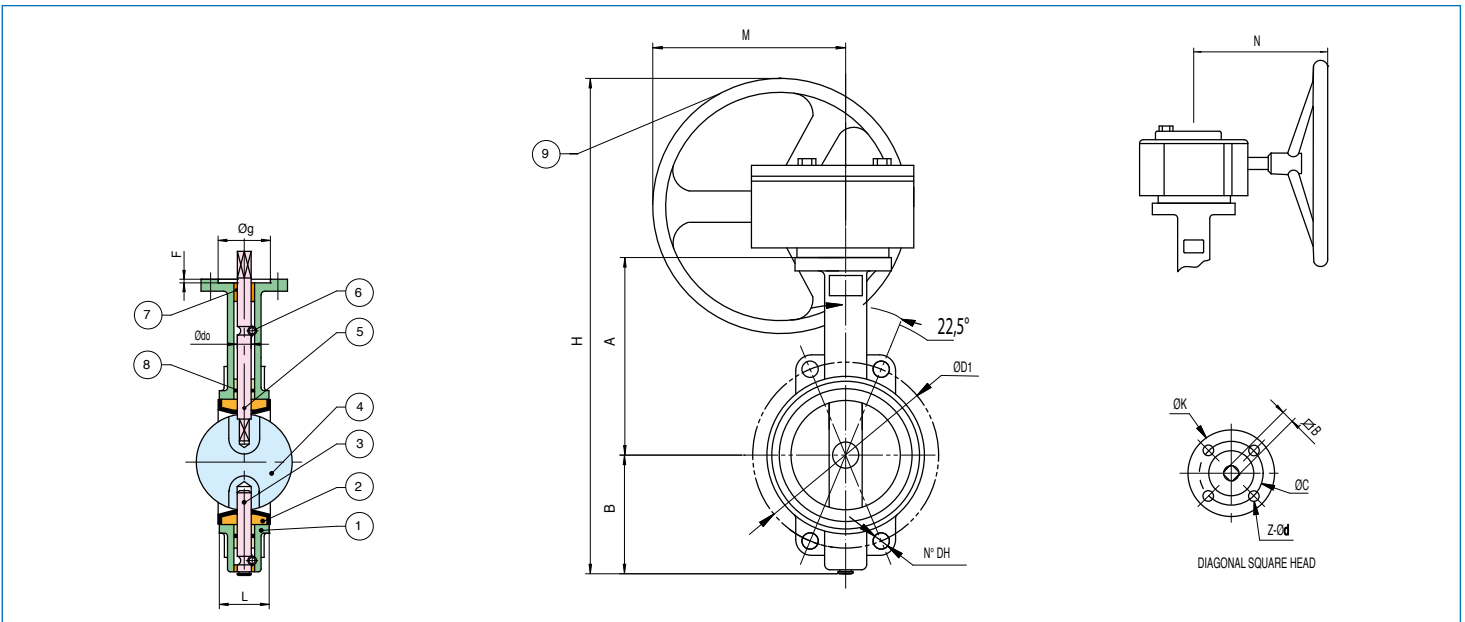

N Pcs	PART NAME	MATERIAL	N Pcs	SIZE	ØC ISO	B	A	B	L	H	M	N	Ødo	UPPER FLANGE				DISC	WAFER	WT.	SEAT TORQUE				CV (GPM@ 1psi)	
														ØK	Z-Ød	Øg	F				ØD1	N°-DH	Lbs	100 psi	200 psi	50% OP
1	BODY	CAST IRON	1	1"1/2	F05	9 mm	7.24	2.97	1.61	13.12	4.75	6.00	0.50	3.03	4-0.28	1.38	0.12	4.74	4-0.75	16.3	111	133	35	108		
2	SEAT	EPDM (30F to 250F)	1	2"	F05	9 mm	7.60	3.15	1.65	13.93	4.75	6.00	0.50	3.03	4-0.28	1.38	0.12	4.74	4-0.75	17	126	146	45	135		
3	LOWER SHAFT	SS 416	1	2"1/2	F05	9 mm	8.15	3.50	1.76	14.83	4.75	6.00	0.50	3.03	4-0.28	1.38	0.12	5.49	4-0.75	18.6	134	167	65	220		
4	DISC G500N	IRON NYLON 11	1	3"	F05	9 mm	8.38	3.74	1.78	15.31	4.75	6.00	0.50	3.03	4-0.28	1.38	0.12	6.00	4-0.75	19.9	205	223	70	300		
	DISC G500S	STAINLESS STEEL		4"	F07	11 mm	9.13	4.49	2.05	16.8	4.75	6.00	0.62	3.54	4-0.35	2.17	0.12	7.50	4-0.75	22.3	339	386	140	605		
5	UPPER SHAFT	SS 416	1	5"	F07	14 mm	9.60	5.00	2.14	17.78	4.75	6.00	0.75	3.54	4-0.35	2.17	0.12	8.50	4-0.87	26.9	523	602	235	1010		
6	LOCATING PIN	CARBON STEEL	1	6"	F07	14 mm	10.16	5.47	2.20	18.81	4.75	6.00	0.75	3.54	4-0.35	2.17	0.12	9.50	4-0.87	28.7	677	996	360	1620		
7	BUSHING	P.T.F.E.	1	8"	F10	17 mm	12.01	6.89	2.34	24.73	8.35	9.84	0.87	4.92	4-0.47	2.76	0.14	11.75	4-0.87	57.8	1205	1864	715	3205		
8	O-RING	EPDM	1	10"	F10	22 mm	13.27	7.99	2.58	27.03	8.35	9.84	1.12	4.92	4-0.47	2.76	1.40	14.25	4-1.00	70.9	1890	3140	1225	5305		
9	GEAR	CAST IRON	1	12"	F10	22 mm	15.04	9.53	3.03	30.34	9.06	8.94	1.24	5.51	4-0.47	2.76	1.40	17.00	4-1.00	104.6	2808	4767	1900	8250		