

ITEM	DESCRIPTION	MATERIAL	TREATMENT	Q.TA' DA	Q.TA' SR
1	Body	Stainless steel		1	1
2	Anti-blowout pinion	Stainless steel		1	1
• 3	O-ring	NBR		1	1
• 4	Spacer ring	POM		1	1
• 5	O-ring	NBR		1	1
• 6	O-ring	NBR		1	1
7	Cam	Stainless steel		1	1
8	Spacer	POM		1	1
• 9	Spacer	POM		1	1
10	Washer	Stainless steel		1	1
11	Snap ring	Stainless steel		1	1
12	Piston	Die cast aluminium	Hard anodized	2	2
• 13	O-ring	NBR		2	2
• 14	Antifriction ring	POM		2	2
• 15	Thrust block	POM		2	2
16	Stop bolt retaining nut	Stainless steel		2	2
17	Stop bolt	Stainless steel		2	2
18	External spring	steel	Powder coating (bonderizing)	0	See spring setting
19	Internal spring	Steel	Powder coating (bonderizing)	0	
20	Left end cap	Stainless steel		1	1
21	Right end cap	Stainless steel		1	1
22	End cap seats	NBR		2	2
23	End cap seats	NBR		2	2
24	End cap fixing screw	Stainless steel		8	8
25	Position indicator	Thermoplastic rubber TPE		1	1

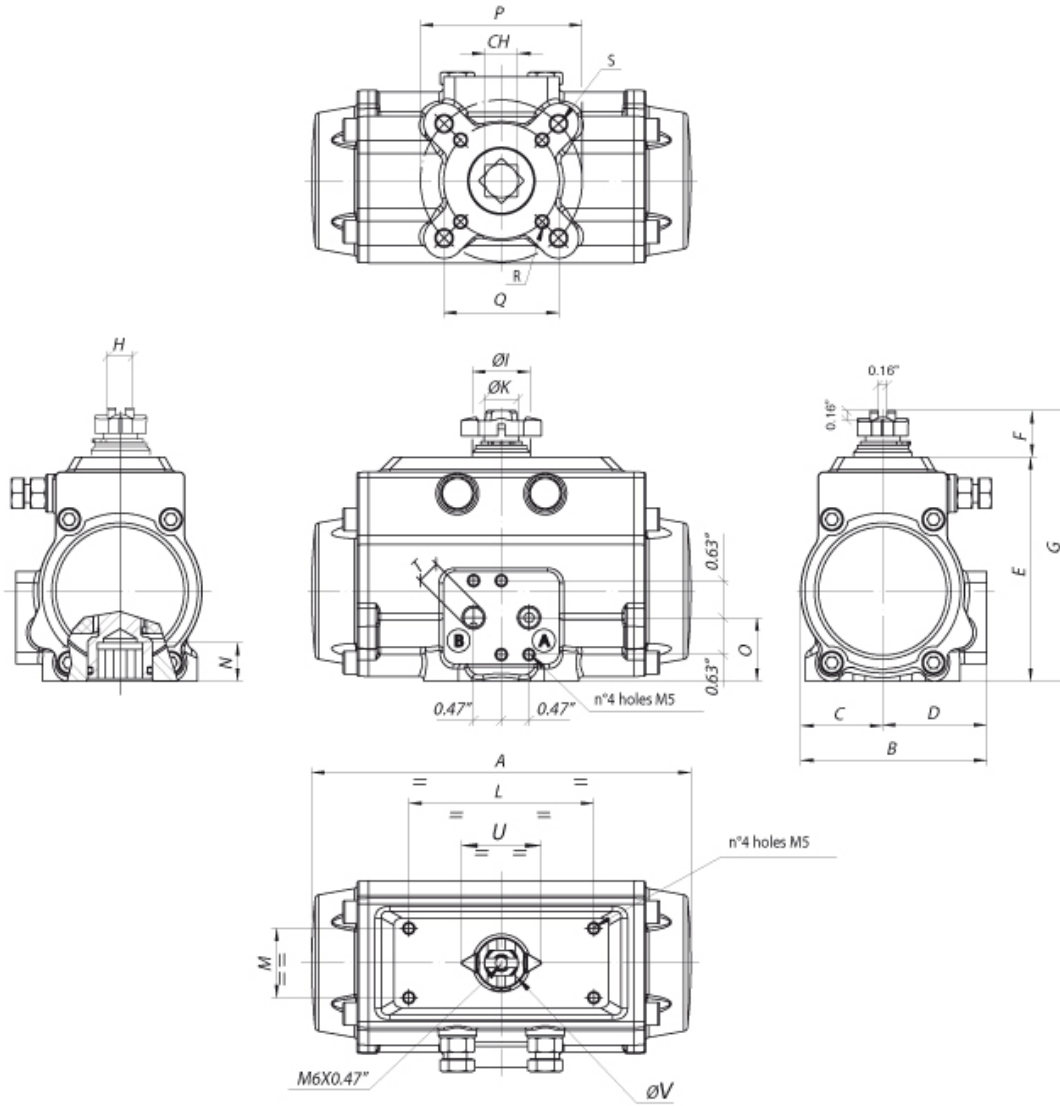

* F04 upon request

(A) CCW rotation

(B) CW rotation

MOD.	DRILLING ISO 5211	CH	A	B	C	D	E	F	G	H	ØI	ØK	L	M	N	O	P	Q	R	S	T NPT	U	ØV
85	F05-F07	0.67	9.47	4.17	1.87	2.30	5.08	0.79	5.87	0.59	1.38	0.86	3.15	1.18	0.75	1.65	2.76	1.97	1/4-20 UNC 2Bx0.31"	5/16-18 UNC 2Bx0.47"	1/8"	1.65	1.14

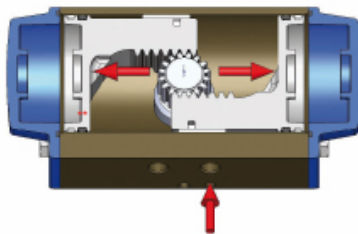

Top view

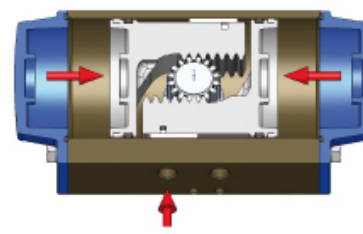

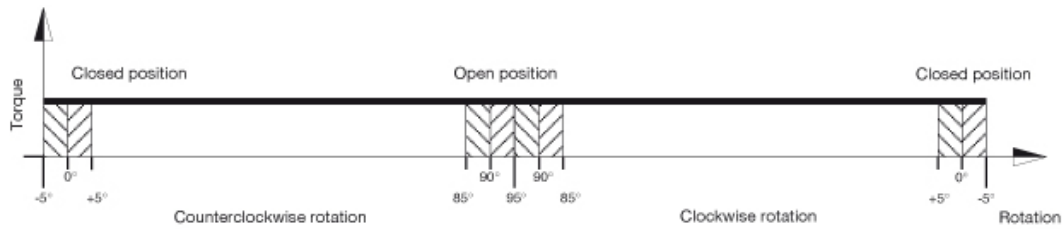

With reference to the above diagram it can be noted that the torque of a double acting actuator remains constant through-out the complete action. The user can decide on which model to choose according to his/her own specific requirements, using the following guidelines:

1. Define the maximum torque of the valve to automate.
2. To obtain a safety factor increase the torque value chosen by 25-50% (subject to the type of valve and working conditions).
3. Once the torque value suggested is obtained consult the torque chart and in relation to the corresponding air pressure find a torque value exact to or exceeding the one obtained.
4. Once the torque value is determined move horizontally to the column "model" to find the actuator model required.

TYPE	AIR SUPPLY PRESSURE (psi)							
	40	50	60	70	80	90	100	115
	TORQUE OUTPUT DOUBLE ACTING ACTUATORS (in-Lbs)							
DA 85	406	514	628	744	853	960	1072	1237

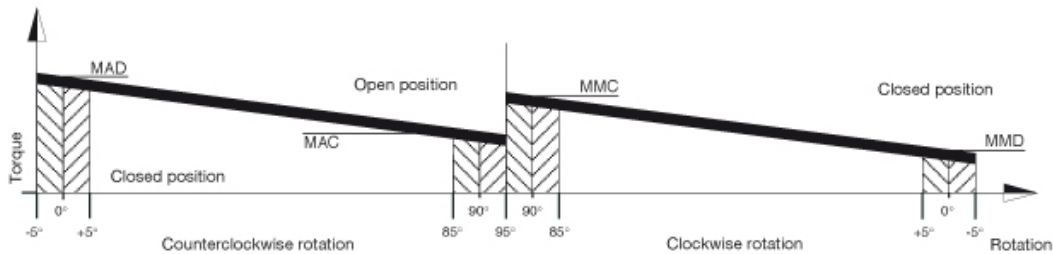
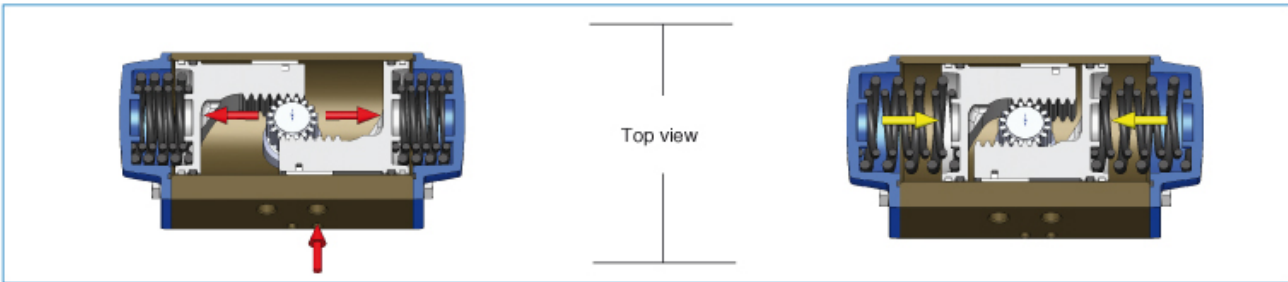

With reference to the above diagram the torque of a spring return actuator is not constant but decreasing. This is due to the action of the springs that when compressed during air actuation counteract the piston movement and accumulate energy which will be available in a decreasing way during the rotation inversion. The torque given by the actuator is defined by four fundamental values.

Opening rotation

MAD = Actuator torque with unfolded springs
 MAC = Actuator torque with compressed springs.

Closing rotation

MMC = Torque with compressed springs.
 MMD = Torque with unfolded springs

The user can decide on which model to choose according to his/her own specific requirements, using the following guidelines:

1. Define the maximum torque of the valve to automate.
2. To obtain a safety factor increase the torque value chosen by 25-50% (subject to the type of valve and working conditions).
3. Once the torque value suggested is obtained consult the torque chart and in relation to the corresponding air pressure find the torque value exact to or exceeding the one obtained, taking account of the lower value between the MMD and MAC values.
4. Once the torque value is determined move horizontally to the column "model" to find the actuator model required.

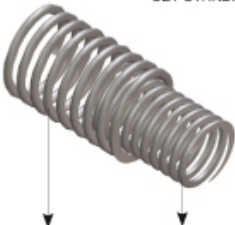
SPRING SETTING		
SET STANDARD 05		
		
SET	EXTERNAL SPRING	INTERNAL SPRING
01	1	1
02	2	-
03	1	2
04	2	1
05	2	2

MOD	SET	SPRING TORQUE (in-Lbs)		AIR SUPPLY PRESSURE (psi)															
				2,5	3	4	5	5,5	6	7	8	TORQUE OUTPUT SPRING RETURN ACTUATORS (in-Lbs)							
		0° MMD	90° MMC	0° MAD	90° MAC	0° MAD	90° MAC	0° MAD	90° MAC	0° MAD	90° MAC	0° MAD	90° MAC	0° MAD	90° MAC	0° MAD	90° MAC	0° MAD	90° MAC
SR65	1	143	242	238	109	349	219	460	330										
	2	176	298			316	163	427	274	537	384								
	3	215	361					387	211	498	322	609	432	720	543				
	4	248	417					354	155	465	265	576	376	687	487	797	633		
	5	321	536							392	146	503	257	614	368	725	478	891	645

WORKING TIME (SEC)		
COUNTERCLOCKWISE ROTATION (DA)	CCW	0,36
CLOCKWISE ROTATION (DA)	CW	0,25
COUNTERCLOCKWISE ROTATION (SR)	CCW	0,32
CLOCKWISE ROTATION (SR)	CW	0,30

WEIGHT CHART (Lbs)	
DOUBLE ACTING	16,54
SPRING RETURN	18,41

ACTUATOR AIR CONSUMPTION CHART		Litres: 1 Litre = 1000 cm3
COUNTERCLOCKWISE ROTATION (DA/SR)	CCW	31,12
CLOCKWISE ROTATION (DA)	CW	39,06