

ITEM	DESCRIPTION	MATERIAL	TREATMENT	Q.TA' DA	Q.TA' SR
1	Body	Stainless steel		1	1
2	Anti-blowout pinion	Stainless steel		1	1
• 3	O-ring	NBR		1	1
• 4	Spacer ring	POM		1	1
• 5	O-ring	NBR		1	1
• 6	O-ring	NBR		1	1
7	Cam	Stainless steel		1	1
8	Spacer	POM		1	1
• 9	Spacer	POM		1	1
10	Washer	Stainless steel		1	1
11	Snap ring	Stainless steel		1	1
12	Piston	Die cast aluminium	Hard anodized	2	2
• 13	O-ring	NBR		2	2
• 14	Antifriction ring	POM		2	2
• 15	Thrust block	POM		2	2
16	Stop bolt retaining nut	Stainless steel		2	2
17	Stop bolt	Stainless steel		2	2
18	External spring	steel	Powder coating (bonderizing)	0	See spring setting
19	Internal spring	Steel	Powder coating (bonderizing)	0	
20	Left end cap	Stainless steel		1	1
21	Right end cap	Stainless steel		1	1
22	End cap seats	NBR		2	2
23	End cap seats	NBR		2	2
24	End cap fixing screw	Stainless steel		8	8
25	Position indicator	Thermoplastic rubber TPE		1	1

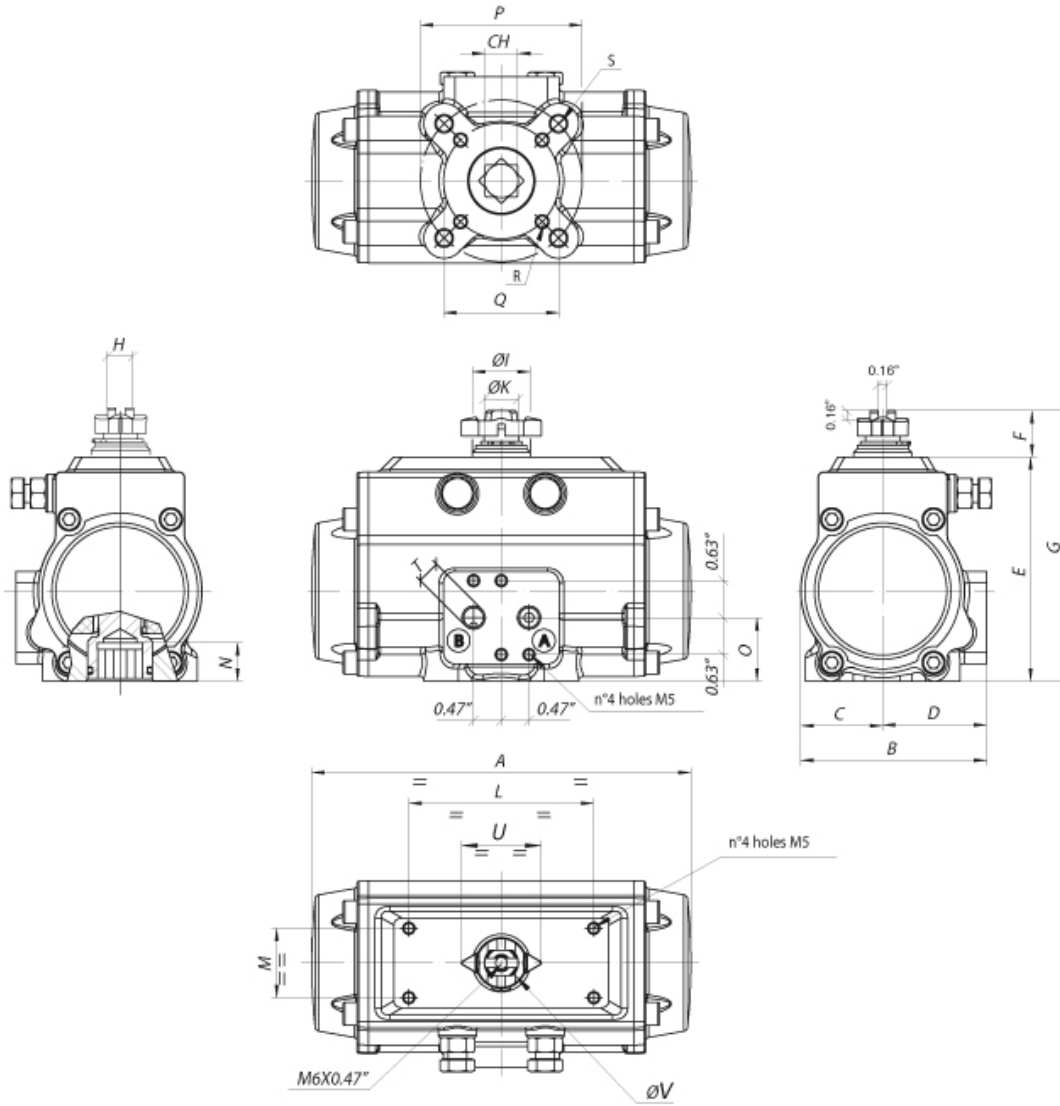

\* F04 upon request

(A) CCW rotation

(B) CW rotation

MOD.	DRILLING ISO 5211	CH	A	B	C	D	E	F	G	H	ØI	ØK	L	M	N	O	P	Q	R	S	T NPT	U	ØV
63	F05-F07	0.55	6.46	3.17	1.40	1.77	3.82	0.79	4.61	0.43	0.98	0.59	3.15	1.18	0.63	1.08	2.76	1.97	1/4-20 UNC 2Bx0.31"	5/16-18 UNC 2Bx0.47"	1/8"	1.36	0.87

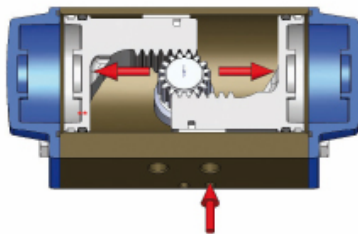

Top view

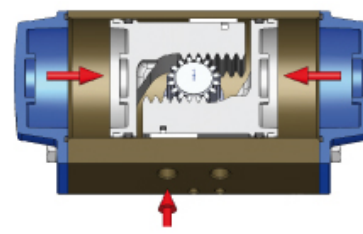

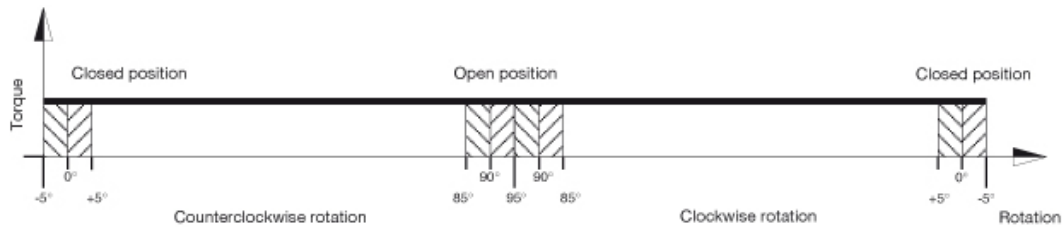

With reference to the above diagram it can be noted that the torque of a double acting actuator remains constant through-out the complete action. The user can decide on which model to choose according to his/her own specific requirements, using the following guidelines:

1. Define the maximum torque of the valve to automate.
2. To obtain a safety factor increase the torque value chosen by 25-50% (subject to the type of valve and working conditions).
3. Once the torque value suggested is obtained consult the torque chart and in relation to the corresponding air pressure find a torque value exact to or exceeding the one obtained.
4. Once the torque value is determined move horizontally to the column "model" to find the actuator model required.

TYPE	AIR SUPPLY PRESSURE (psi)							
	40	50	60	70	80	90	100	115
	TORQUE OUTPUT DOUBLE ACTING ACTUATORS (in-Lbs)							
DA 63	152	193	238	282	320	361	405	469

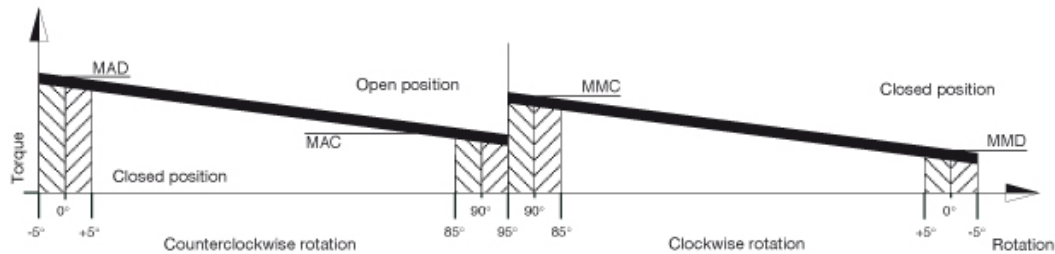
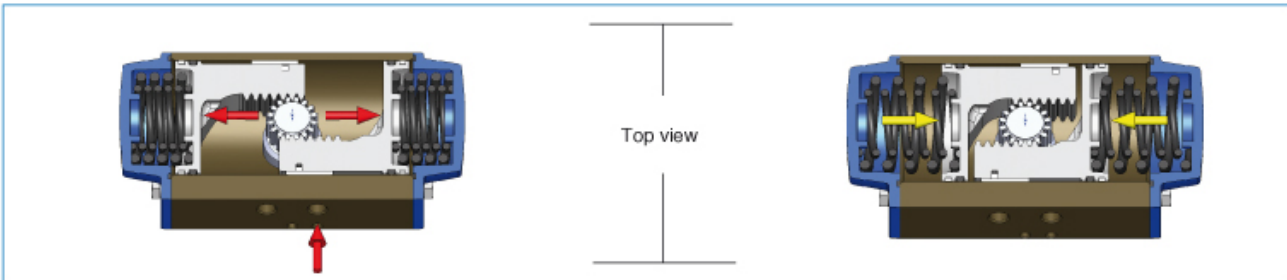

With reference to the above diagram the torque of a spring return actuator is not constant but decreasing. This is due to the action of the springs that when compressed during air actuation counteract the piston movement and accumulate energy which will be available in a decreasing way during the rotation inversion. The torque given by the actuator is defined by four fundamental values.

**Opening rotation**

MAD = Actuator torque with unfolded springs  
 MAC = Actuator torque with compressed springs.

**Closing rotation**

MMC = Torque with compressed springs.  
 MMD = Torque with unfolded springs

The user can decide on which model to choose according to his/her own specific requirements, using the following guidelines:

1. Define the maximum torque of the valve to automate.
2. To obtain a safety factor increase the torque value chosen by 25-50% (subject to the type of valve and working conditions).
3. Once the torque value suggested is obtained consult the torque chart and in relation to the corresponding air pressure find the torque value exact to or exceeding the one obtained, taking account of the lower value between the MMD and MAC values.
4. Once the torque value is determined move horizontally to the column "model" to find the actuator model required.

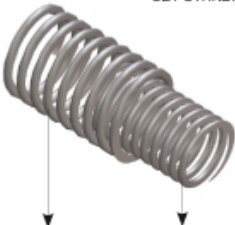
SPRING SETTING		
SET STANDARD 05		
		
SET	EXTERNAL SPRING	INTERNAL SPRING
01	1	1
02	2	-
03	1	2
04	2	1
05	2	2

MOD	SET	SPRING TORQUE (in-Lbs)		AIR SUPPLY PRESSURE (psi)																															
				2,5				3				4				5				5,5				6				7				8			
				TORQUE OUTPUT SPRING RETURN ACTUATORS (in-Lbs)																															
0° MMD	90° MMC	0° MAD	90° MAC	0° MAD	90° MAC	0° MAD	90° MAC	0° MAD	90° MAC	0° MAD	90° MAC	0° MAD	90° MAC	0° MAD	90° MAC	0° MAD	90° MAC	0° MAD	90° MAC	0° MAD	90° MAC														
SR63	1	44	85	92	38	134	80	176	122																										
	2	58	109			120	56	162	98	204	140																								
	3	71	128					149	79	191	121	233	162	275	204																				
	4	85	152					136	54	177	96	219	138	261	180	303	222																		
	5	111	196								151	53	193	95	235	136	276	178	339	241															

WORKING TIME (SEC)		
COUNTERCLOCKWISE ROTATION (DA)	CCW	0,11
CLOCKWISE ROTATION (DA)	CW	0,10
COUNTERCLOCKWISE ROTATION (SR)	CCW	0,13
CLOCKWISE ROTATION (SR)	CW	0,13

WEIGHT CHART (Lbs)	
DOUBLE ACTING	6,90
SPRING RETURN	7,59

ACTUATOR AIR CONSUMPTION CHART		
Litres: 1 Litre = 1000 cm3		
COUNTERCLOCKWISE ROTATION (DA/SR)	CCW	11,6
CLOCKWISE ROTATION (DA)	CW	14,04