

# 509\*/509T\*\* 1/4"-3"

Available with Press x Press Ends  
or Press x Threaded.  
Please consult factory.

Shop Milwaukee 509

**Bronze Check Valve  
Horizontal Swing  
125 SWP-200 WOG†  
Threaded Ends**

**Conforms to: MSS SP-80. Type 3\*, Type 4\*\*  
Class 125, Threaded Ends**

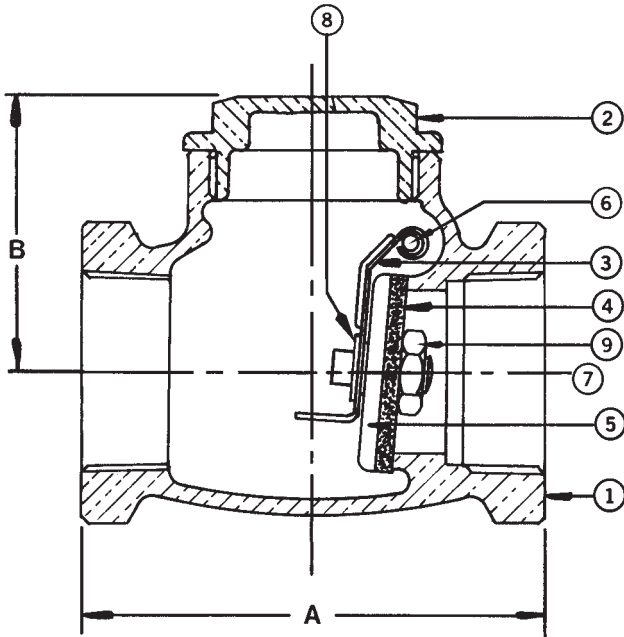

DIMENSIONS - INCHES / MILLIMETERS				
UNITS	SIZE	A	B	C <sub>v</sub>
Inches	1/4	2.13	1.44	3.3
mm	6.4	54.0	36.5	
Inches	3/8	2.13	1.44	6.0
mm	9.5	54.0	36.5	
Inches	1/2	2.31	1.44	10.0
mm	12.7	58.8	36.5	
Inches	3/4	2.63	1.69	18.0
mm	19.1	66.7	42.9	
Inches	1	3.25	2.00	31.0
mm	25.4	82.6	50.8	
Inches	1 1/4	3.56	2.13	54.0
mm	31.8	90.5	54.0	
Inches	1 1/2	4.00	2.38	76.0
mm	38.1	101.6	60.3	
Inches	2	4.75	2.81	131.0
mm	50.8	130.2	208.0	
Inches	*2 1/2	6.00	3.63	192.0
mm	63.5	152.4	92.1	
Inches	*3	6.88	4.19	297.0
mm	76.2	174.6	106.4	

† Non-Shock  
\* 509 Only

Rev. 13

MATERIAL LIST			
NO.	PART	MATERIAL	SPECIFICATION
1	Body	Bronze	ASTM B 62
2	Cap	Bronze	ASTM B 62
3	Lever	St. Steel - 509	Commercial 1/4" to 2" Incl.
		Bronze - 509	ASTM B 584 2 1/2" and 3"
		Brass - 509T	ASTM B 16 1/4" to 2" Incl.
4	Disc	Brass - 509	ASTM B 16 1/4" to 3/4" ASTM B 453 1" to 1 1/2"
		Bronze - 509	ASTM B 62 2" to 3"
		PTFE - 509T	Commercial
		5	Disc Holder (509T Only)
		Bronze	ASTM B 62 1" to 3"
6	Pin	St. Steel	Commercial
7	Disc Nut	Brass	ASTM B 16
8	Retaining Ring	St. Steel	Commercial
9	Plug (not shown)	Brass - 509	ASTM B 16
10 <sup>1</sup>	Washer (not shown)	Brass - 509	ASTM B 16

<sup>1</sup> Used on 2 1/2" and 3" sizes only

Note: Not intended for use in potable water.



**MILWAUKEE VALVE**

www.milwaukeevalve.com